

Design And Modification Of Sugarcane Bud Scooping Machine

Sanjay Patil Sir¹, Nikhil Nangare², Aditya Waghmare³, Mayur Zope⁴, Meet Thakker⁵

¹Diploma in Mechanical Engineering, Founder of Sumeet Technologies, Narhe Gaon, Pari-chowk, Pune, India.

²B.E (Mechanical), Department of Mechanical Engineering, NBN Sinhgad School of Engineering, Pune, India.

³B.E (Mechanical), Department of Mechanical Engineering, NBN Sinhgad School of Engineering, Pune, India.

⁴B.E (Mechanical), Department of Mechanical Engineering, NBN Sinhgad School of Engineering, Pune, India.

⁵B.E (Mechanical), Department of Mechanical Engineering, NBN Sinhgad School of Engineering, Pune, India.

Abstract- In today's world, the entire requirements are being fulfilled through automatic system. The demand for reducing the wastage of sugarcane. So the search of automatic system is completed by our project. One alternative to reduce the mass and improve the quality of seed cane would be to plant excised axillary buds of cane stalk, popularly known as bud chips. These bud chips are less bulky, easily transportable and more economical seed material. The bud chip technology holds great promise in rapid multiplication of new cane varieties. The problem of establishment and initial growth could be addressed by application of appropriate plant growth regulators and essential nutrients.

Keywords – scooping Bled,

1. INTRODUCTION

The current method of deploying sugarcane sets proved laborious, time consuming and costly. Mr. Roshanlal Vishwakarma, a farmer in Mekh village, Madhya Pradesh, faced acute difficulties in cultivation and alternative method of planting individual saplings did not help. It was hampered by lack of availability of saplings in large numbers. The farmer wondered whether the sugarcane buds, instead of being planted, could be sown like potatoes on the fields. Hard labor He discussed this idea with an expert. Based on the encouraging feedback he received to give it a try, the farmer started working on the idea and developed a simple device after two years of persistent and hard labor. The device, called sugarcane bud chipper, is floor-mounted and equipped with a knife with a semicircular edge to surgically cut out the buds in a high impact operation, with clean finish and practically no damage to the cane. "Using this device a person can remove nearly 100 buds in an hour," says Mr. Vishwakarma.

Handling capacity the machine can also chop the cane into small pieces, is flexible, and can handle various sugarcane sizes and diameters. Traditional hand-held cutting tools create a strain on the hands and thumb, cause wastage, and damage with slanting cuts, and are incapable of dealing with hard plant grafting. Machine details The bud-chipper consists of a surface plate, holding stand, reciprocating assembly, actuating lever with adjustable screws, connector, U-shaped cutting knife bolted with a spring stopper projecting downward into a matching groove, supporting studs and spiral spring for generating thrust. The machine, priced at Rs. 600, comes with a guarantee offer of 6 month. "The unit allows the user to be comfortably seated on the ground and continuously feed the cane with the left hand, while swinging the right arm in a smooth arc to cut the sugarcane buds using the ergonomic spring loaded handle. Clean cut the semicircular cutting blade delivers a clean and complete cut in a two step notch and cut operation. The high impact cutting action with outstretched arm and high shoulder slinging action generates the desired fast impact force for clean cutting," explains the farmer. The machine requires no power or fuel to run it, weighs a few kilograms making transport easy. The scope of this equipment lies beyond just removing buds from the sugarcane. It can be used more broadly as grafting equipment wherein buds of large plants can also be removed. "We designed the unit in such a way that it could handle any cane size with the user conveniently sitting on the ground and work. "Experimenting with various cutting shapes, We finally developed a U-shaped cutting profile for cutting the bud in one swift movement of the spring loaded handle without damaging the rest of the cane stalk," Table top version while toying with the idea of a table top version instead of existing floor based version, he realized that the design would become more complex to feed the cane at the exact height when used by

various users. Secondly, he noticed rural users were more comfortable with the floor based model than table-top handling. He also started developing a folding type bud chipper which did not find favor among local users. So he discontinued the model. Many sugarcane farmers in the region are now using Mr. Vishwakarma's machine to save time and money .The large mass of planting material poses a great problem in transport, handling and storage of seed cane and undergoes rapid deterioration thus reducing the viability of buds and subsequently their sprouting. One alternative to reduce the mass and improve the quality of seed cane would be to plant excised axillary buds of cane stalk, popularly known as bud chips. These bud chips are less bulky, easily transportable and more economical seed material. The bud chip technology holds great promise in rapid multiplication of new cane varieties. The left-over cane can be well utilized for preparing juice or sugar or jaggery.

2. OBJECTIVE

To modify the design of scooping machine which can allow the farmer to cut the sugarcane bud in a form which can be utilized as a planting for agricultural of sugarcane. With ease and thus reducing the manual work of farmer and increases the production.

3. METHODOLOGY

- 1) **Change Manual Method in to Automatic** - By using appropriate capacity of single phase motor, gearbox which will reduce wastage and increase productivity as it will reduce strain on hands of worker and more emphasis on safety of operator.
- 2) **New cutting technology** - The research work in this domain was studied and new methods were developed to achieve desired goal.
- 3) **Single phase operation** - The power supplied to machine is single phase so to make it easy to operate at any location.
- 4) **Safety** - Highest priority is given to safety of the operator.

4. Construction & Working of Chaff Cutting Machine

4.1 Components

A. Power Source - Electric Motor(Single Phase)



Fig -1: Electric Motor

Electric motor is an electrical machine that is used to convert electrical energy into mechanical energy. For smaller loads as in household application. Although traditionally used in fixed-speed service, induction motors are increasingly being used with variable-frequency drives in variable-speed service. VFDs offer especially important energy savings opportunities for existing and prospective induction motors in variable-torque centrifugal fan, pump and compressor applications.

B. Gear Box

Gearbox is used to reduce speed of shaft and to control the rotation motion. Most modern gearboxes are used to increase torque while reducing the speed of a prime mover output shaft. This means that the output shaft of a gearbox rotates at a slower rate than the input shaft, and this reduction in speed produces a mechanical advantage, increasing torque. Some of the simplest gearboxes merely change the physical rotational direction of power transmission. Worm and worm gear box is used to transmit the output power. A gear box designed using a worm and worm-wheel is considerably smaller than one made from plain spur gear, and has its drive axes at 90° to each other. With a *single start* worm, for each 360° turn of the worm, the worm-gear advances only one tooth of the gear.

C. Shaft

A Shaft is a rotating element, usually circular in cross section; line shaft is used to transmit power from one shaft to another, or from the machine which produces power, to the machine which absorbs power. Shaft is used to transmit power from motor to gearbox and from gearbox to mechanism. A shaft is an element used to transmit power and torque, and it can support reverse bending. Most shafts have circular cross sections, either solid or tubular. Shafts have different means to transmit power and torque. Shafts are able to avoid vibration of the elements, and assure an efficient transmission of power and torque, some changes in the cross-section of the shaft can be made.

D. Cutter

This is the main section of the scooping machine. The scoop cutter is used to cut the sugarcane bud and to get the same size of sugarcane bud. Because of scooping cutter the wastage of sugarcane reduces and safety of farmer increases.

E. Spring

A spring is an elastic object used to store mechanical energy. When a coil spring is compressed or stretched slightly from rest, the force it exerts is approximately proportional to its change in length. Spring is used to give the upward and downward direction to the cutter. Because of spring the cutter move upward and downward direction. Spring is assembled with the cutter.

F. Supporting plate

Supporting plate is used to support sugarcane for cutting and accurate bud cut. Also this is used to reduce wastage and manual safety. This plate is used to get equal size and shape of bud.

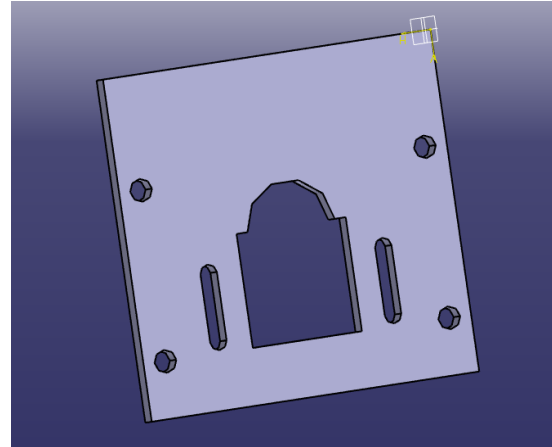

Fig - 1: Supporting plate

F. Supporting frame

The whole assembly is mounted on this frame. The complete frame is made up of mild steel. To give sufficient height to machine.

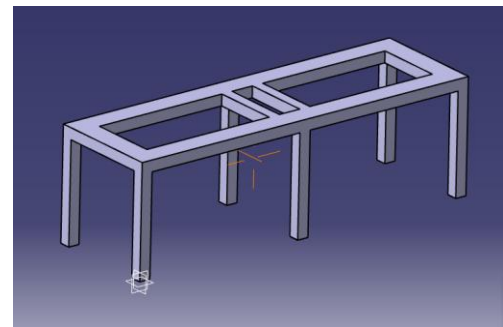

Fig - 2: Supporting Frame

G. Bud collection box

Bud collection box is used to collect buds which are cut by cutter at supporting plate. So that proper collection of buds can be done. Because of these plate all buds are collected at a one place.

H. Ellipse

Ellipse is used to change circular motion to linear motion. The output of shaft is in circular motion and it is connected to the ellipse. Major and Minor axis are connected towards the top section of Spring head.

4.2 Procedure-

1. Supply power source to Electric motor-

Here we are using single phase 2 H.P motor so we require single phase power supply. Input speed of our electric motor is 1425 rpm .In order to rotate the shaft we have to rotate them by using power drives.

2. Power transmission through Gearbox which are mounted on shaft

For transmitting power we choose gearbox arrangement. This gearbox arrangement is coupled to Ellipse by using shaft and key. Hence liner motion of cutter occurs.

3. To remove sugarcane bud-

We keep the sugarcane on the Supporting Plate. The linear motion of cutter helps to cut the bud of sugarcane and the same size of bud is collected. Collection of sugarcane is done in the box

4.3 Bud of Sugarcane



5. CONCLUSION

1. We have used scooping cutter and 2 H.P single phase which require low electricity & easily available anywhere so it's beneficial to farmer.
2. By using different types of blades we can obtain different types of shape of product.
3. By using this machine we can cut the sugarcane bud so that it can be utilized for farming.

6.REFERENCES

1. P.B.Khope, J.P.Modak, Establishing empirical relationship to predict the cutting phenomenon energized by human powered flywheel motor (hpfm).

2. M. V. Gudadhe, J. P. Modak, Design of Experimentation for the Formulation of an Approximate Experimental Model International Journal of Research in Engineering Science and Technologies, Volume 1, Issue 1, May 2015
3. P. B. Khope, J. P. Modak, Development and Performance Evaluation of a Human Powered Motor Operated Cutter, International Journal of Scientific & Technology Research, Volume 2, Issue 3, March 2013