

DESIGN AND FABRICATION OF ENGINE OIL INDICATOR

Partha Pratim Deori¹, Franky Kumar Kalia², Debajit Kumar Sandilya³

¹ Assam Engineering College, Guwahati.

² Assam Engineering College, Guwahati.

³ Assam Engineering College, Guwahati.

Abstract - In the present study the common problem of lubrication of diesel engine due to lack of lubricating oil in the oil sump is attempted to be resolved. The problem, that generally occurs during the running condition of vehicle when the lubricating oil level goes down to/below a critical point, is that the oil pump is unable to supply sufficient amount of lubricating oil to the different rotating & reciprocating parts of the engine. As a result a sudden break down of the vehicle may occur due to overheating of engine parts without giving any prior indication. In the present study, a self-powered oil level indicator has been designed and fabricated. It consists of a float suspended on one arm of a U-tube. The U-tube carries lubricating oil which supports the float. Necessary electrical connections are made so that circuit is open or closed depending on float position. The electrical circuit is powered by two 1.5V battery and consists of a LED bulb which lights up when the oil level is below the desired level.

Key Words: Oil level, float, indicator, device, electrical circuit, over heating

1. INTRODUCTION

The reciprocating internal combustion engine has a large number of moving parts. Without an adequate film of lubricating oil between the surfaces of the reciprocating and rotating metals parts, the force required to overcome the frictional resistance and the wear on the parts would be very high. When relative motion takes place between the mechanical surface in contact, work is done against the friction force and heat is produced at the surfaces, which may heat the parts to a temperature such that melting or seizure may take place. In IC engine during combustion process, high temperature along with temperature fluctuation is experienced. In addition, the bearing loads also fluctuate. All these make the lubricating problem more critical. Inadequate or improper lubricating of the engine may cause serious engine troubles, such as scored cylinders, piston and piston ring seizure, damaged bearings, engine deposits / sludge and dirty spark plug. Some of these problems occur, when the engine oil level in the oil sump goes below critical level when sufficient amount of engine oil to moving parts of the engine cannot be delivered. Therefore, it is quite necessary that, the engine oil level is constantly monitored to ensure that there is sufficient amount of oil

within the lubrication system to provide proper lubrication of the engine. Though, as on today, automobile technology has reached a prominent state, yet due to improper implementation of knowledge crucial problems are sometimes observed. One of the above problems due to low level of engine oil in the oil sump has been analysed. The problem is that during the running condition of a vehicle particularly at night or for long distances travel between filling stations, the lubricating oil level cannot be checked easily with a dipstick. It is therefore highly desirable that the operator be made aware whenever the oil level drops to a critical level and addition of oil is necessary. So, a floating type oil level indicator has been designed and fabricated which will reduce the driver's effort to check the oil level from time to time and prevent engine seizure due to negligence of the driver or accidental depletion of engine oil in the sump.

2. AIMS AND OBJECTIVES

The aim in the present study is to design and fabricate an oil level indicator which may be fitted in the existing oil sump of a vehicle and would act as an early warning system for the driver of any lack of lubrication in the engine. In addition, it should be simple and rugged in construction and easy to maintain and repair. Moreover, the device should come at an affordable price and the design should be such that it can be adapted to any vehicle without tampering the engine.

3. DESIGN AND WORKING PRINCIPLE

3.1 DESIGN AND CONSTRUCTION DETAILS OF U-TUBE TYPE FLOATING OIL LEVEL INDICATOR

In a diesel engine (Make Tata; Model No. 483DLDIC) the amount of engine oil required is 7 (Seven) litres in ideal condition. When the engine is running, 5(five) litres of engine oil is supplied to the crankcase and different parts of the engine and the remaining 2 (two) litres remains in the oil sump for further circulation. To study the amount of engine oil in the oil sump, it is envisaged the developed that the entry of the floating type indicator in to the oil sump should be such a height that the under normal working condition of the engine at least 2.5 litres of engine oil should be remain in the oil sump. It is experimentally observed that this height is 44mm above the bottom face of the engine oil sump. The beauty of any design lies in its simplicity and its

effectiveness. In the present study, to minimise the effect of turbulence of the engine oil in the sump on the designed floating type indicator, the float is placed on the other side of a U-Tube as shown in figure-4.

3.2 DIFFERENT ELEMENTS OF THE FLOATING TYPE INDICATOR DEVICE

3.2.1 U-TUBE: Figure 4 is a schematic representation of the u-tube. The u-tube is made by joining 3(three) nos. of small sized GI pipe element. The internal pipe diameter of each pipe is 25.4mm. The length of the two pipes elements are 100mm each and third no. pipe element is of 150mm length. A socket of 40mm length is attached on the end of the 150mm pipe element through threaded joint. All the three pipes are joined to one another by elbow sockets as shown in Figure 1.

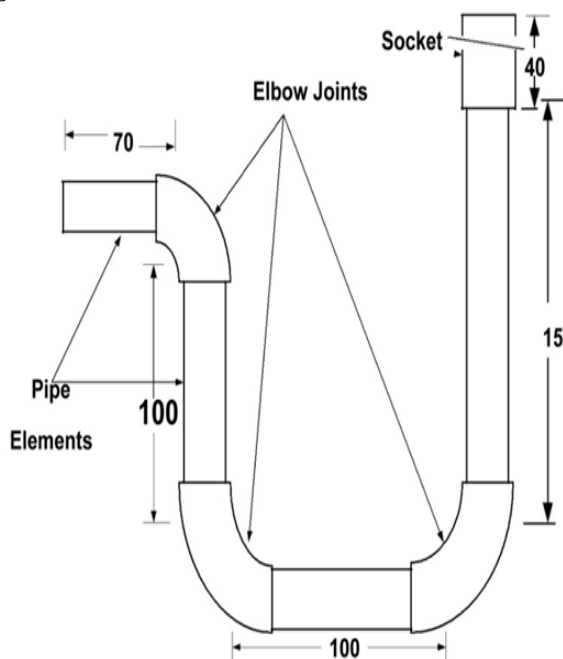

Fig 1. Schematic Diagram of U-tube (all dimensions in mm)

The floating type indicator is mounted in the one end of the u-tube with the open end of the 150mm pipe. The other end of the u-tube is welded to the oil sump through a pipe elbow joint of same diameter and length of 70mm, at the desired height from the bottom face of the oil sump. The oil sump and the u-tube are connected through gas welding. Attempt was to make all the joints leak proof. So, liquid pipe sealants (master tite, Teflon) are used for sealing of joints

3.2.2 FLOATING TYPE INDICATOR OR DEVICE

Figure 2 shows the mounting of the floating type indicator on the U-tube. This device is made by using a float, connecting bar and an electrical connection switch.

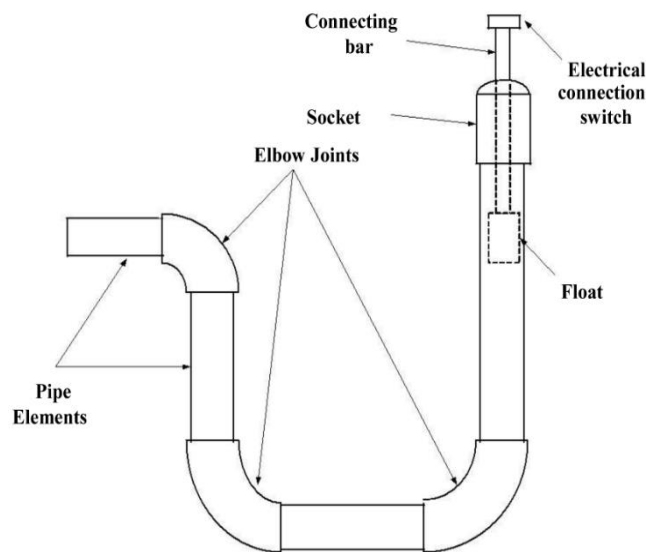

Fig 2. Complete schematic diagram of the indicator device

3.2.2.1 FLOAT AND CONNECTING BAR

The float is made of high thermal resisting poly-urethane material. The float is a hollow cylinder and closed at both ends. The float diameter is 18mm and its length is 19mm. Since the pipe diameter where it is inserted is 25.4mm, so some clearance is there between the inside pipe wall and the outside wall of the float.

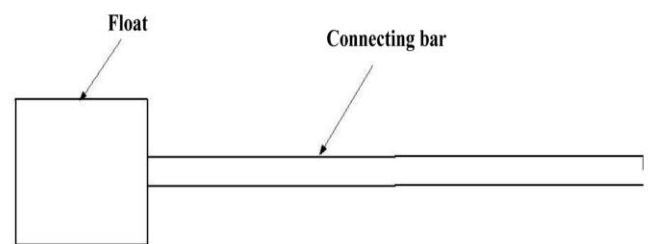

Fig.3 Schematic diagram of Connecting bar and Float .

The clearance is given for free movement of the float along with the engine oil in the 150mm pipe, where the float functions as a piston and the pipe acts as a block. The clearance between the pipe wall and the float is about 3.7mm on all sides of the float is obtained through rough trial and error method, taking into consideration that (a) the lubricant will not seep through the clearance space between the float and the pipe and (b) that tilting of the float in the pipe will not takes place.

A connecting bar of 105mm length and 5.5mm diameter is attached in the longitudinal central axis of the cylindrical float. This bar is made of high thermal resisting

poly-urethane material. In the upper end of the bar, an electrically conductive on-off element is mounted by threaded joint along with an aluminum connector.

3.2.2.2 ELECTRICAL SWITCH

i) **Electrical circuit:** A typical self-contained electrical system for indicating the oil level in the designed and fabricated floating type indicator is shown in the Figure 4.

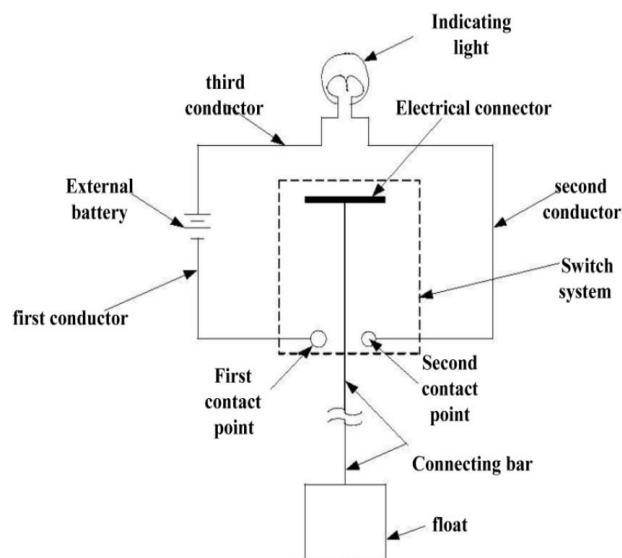

Fig. 4. Schematic representation of the electrical circuit for the oil float indicator

In this electrical system, a battery, indicating light and a switch having an electrically conductive on-off element are provided. The electrical circuit includes suitable electrical conductors, such as first conductor in between (-) ve terminal of the battery and a first contact point, a second conductor between second contact point and light and a third conductor between the light and (+)ve terminal of the battery. The float as shown in Figure 4 carries a circular aluminum disc, which acts as an electrical connector between the two poles when the oil level is low in the sump. In short, this connector is acts as an on-off switch (electrically conductive on-off element) depending on the oil level in the sump.

ii) **Cap:** A cap is provided for protection of the device, from external impurities like dust, water, mud etc. This cap is made of transparent plastic material, so that the electrical switch can be inspected from time to time without dismantling the set-up.

3.3 WORKING PRINCIPLE

Description of the different elements of the floating type

indicator is given in articles 3.1 and 3.2 and in figures 1, 2, 3 and 4.

When the engine oil level in the oil sump is full, then the float will attain a position 'A' as shown in fig. 5.

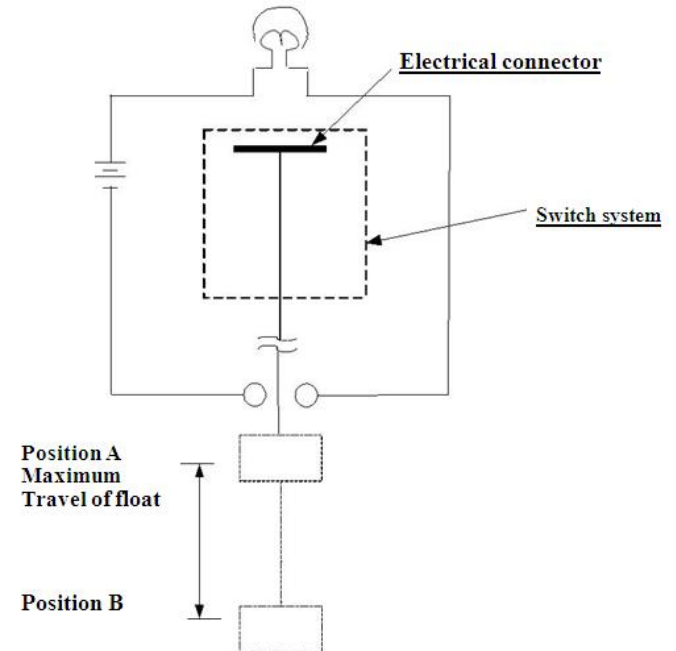

Fig. 5. Schematic diagram of the working of the floating type indicator device.

At that situation the electrical connector is in off position. As the engine oil level goes down to a particular specified level, then the float will move down to the position 'B', Where in the electrical connector (electrically conductive on-off element) completes electrical circuit to light the indicator bulb.

4. TESTING AND EXPERIMENTATION

Testing of the device fabricated is necessary to check and validate the usability of the device. Since, testing of the device was not possible because of non-availability of required vehicle and also direct testing of the device on a running vehicle is not desirable because of unseen defects and inaccuracies in the fabricated device, so it was decided to simulate the condition of a running vehicle through use of a shaker machine. The sump which carries a flange at the open upper end is fitted to the engine block through 25 numbers of screws. Hence, the open top end of the sump is to be closed to carry out the experimentation. A mild steel plate of 3mm thickness is cut out to the required shape and size so as to form the top cover of the sump. Holes of required dimension were drilled on the aforesaid plate.

The sump was filled with water to the required top-up level and the top cover was fastened with the sump through nuts and bolts with a leak-proof gasket in between.

The assembly was then placed on the shaker machine and was given a vigorous shaking motion which was intended to simulate bad road condition to which a vehicle may be subjected. The oil in the sump under such condition will be subjected to vigorous jerking and the test was carried out to ascertain (a) as to whether oil spilling takes place through the tube/electrical device (b) accidental false warning is delivered by the electrical system. After testing the device it is observed that the device has operated satisfactorily without oil spillage or blinking of the warning light.

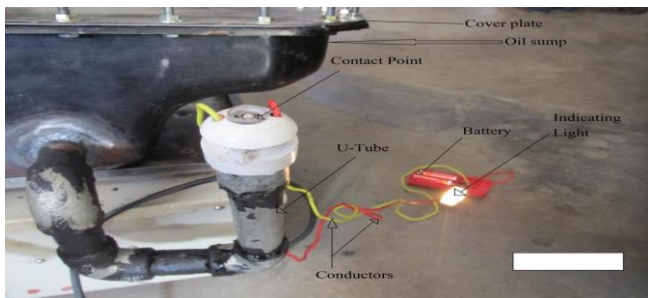

PICTURE 1: Oil level indicator with the oil sump



PICTURE 2: Oil level indicator with the shaker machine.

The water in the sump was then decanted to/below the specified critical level and the sump assembly was again placed on the shaker machine. It was observed that the warning light glowed continuously even when vigorous shaking motion was given to the sump assembly. This ascertained that the warning system is operational even in bad road condition

5. CONCLUSION

A new oil level indicator system has been designed in the present study which will indicate the oil level in the oil sump, if oil level goes down below a specified critical limit. The present study shows that the fabricated engine oil indicator device can successfully indicate depletion of engine oil in the sump below a specified critical level through lighting of a L.E.D bulb. Since the testing was carried out successfully with water (with lower viscosity than engine oil) so it can be safely assumed that oil spillage through the fabricated device will not take place. The designed and

fabricated device can be fitted to any vehicle by brazing the open end of the u-tube to the oil sump.

ACKNOWLEDGMENT

We would like to take the opportunity to extend my sincere gratitude to all those who have provided their assistance and co-operation in bringing out this project work in present form. We wish to express our sincere gratitude to laboratory staff of chemical engineering department and the technical staff of workshop of Assam Engineering College. We would also like to thank Mr. Raju Ahmed for reviewing the project work

6. REFERENCES

1. Hosford W. Harry, "FLUID LEVEL INDICATOR", Ser. No. 169,474, 2565 Startford Road, Cleveland Heights, Ohio, Jan. 29 1962.
2. Henneberry W. James, "ENGINE OIL LEVEL INDICATOR", Appl. No. 839,529, 170 Brixton Rd., S. Garden City, N.Y. 11530. Mar. 14, 1986.
3. Gomery E. Victor, "LOW OIL LEVEL INDICATOR", Appl. No. 11/301,827, Cosmopoli, WA (US), Dec. 12, 2005.
4. Paul V. Voelkan, Hedges D. Joe, "OIL QUALITY SENSOR FOR USE IN A MOTOR", Appl. No. 637,878, Portola Valley, Apr. 25, 1996.
5. Kuczynski R. Steven, De Both H., "LOW OIL SENSOR FORAN INTERNAL COMBUSTION ENGINE", Appl. No. 13,915, New Holstein, Feb. 12, 1987.
6. Mattias Olsson, Anders Magnusson and Sharat C. Prasad., "SIMULATION OF THE FORMING PROCESS OF LIQUID FILLED PACKAGES USING COUPLED EULERIAN-LAGRANGIAN APPROACH", Simulia Customer Conference 2009.
7. S.E. Schwartz, D.J. Smolenski, "DEVELOPMENT OF AN AUTOMATIC ENGINE OIL-CHANGE INDICATOR SYSTEM", SAE Technical Paper 870403, 1987.

BIOGRAPHIES



Name- **Partha Pratim Deori, B.E.**
Mechanical Engineering, GIMT (Gauhati University), M.E. Mechanical Engineering, Assam Engineering College



Name- **Franky Kumar Kalia, B.E. Mechanical Engineering, GIMT (Gauhati University), M.E. Mechanical Engineering, Assam Engineering College**



Name- **Debajit kumar Sandilya, B.E.**