

Boiler Feed Pump Control Using Variable Frequency Drive

Mr. Jay Narkhede¹, Prof. Sawankumar Naik²

¹ M. Tech. (Industrial Automation) Student, Mechatronics Department, SVKM'S NMIMS University

² Asst. Professor, Mechanical Department, SVKM'S NMIMS University
Mumbai-400056, Maharashtra, India

Abstract - Energy conservation is the aim of any industry. Saving fuel and energy cost has been a global issue for every industry. Normally all the company has oversized pumps and motor for the duties they perform. Electric motors use two-third of all electricity in industry, so any chance to reduce this load, even by single figures is highly significant. Boiler feed pumps consume a large fraction of the auxiliary power (in excess of 4 % of unit capacity) used internally within a power plant in pressurizing and forcing the feed water through economizer to the boiler. The changing rotation speed is the most effective and economical way of improving the pump efficiency. Adjustments made to rotation speed causes only a slight decrease in the pump efficiency compared to operation with fixed revolutions. This type of control allows a reduction in electricity consumption in a wide range of loads. The VFD installation cost and the financial burden is balanced against the earning resulting from the associated energy saving.^{[4][5]}

condensation of the steam produced by the boiler. These pumps are normally very high pressure units that take suction from a condensate return system and can be of the centrifugal pump type or positive displacement type.

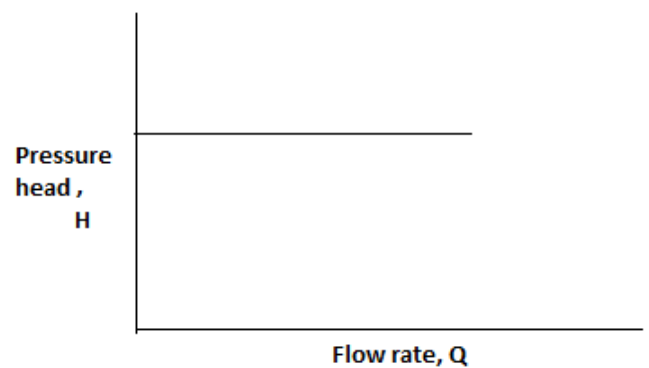

Fig1. Pressure head v/s Flow rate

The boiler is running at a constant pressure head 'H', but the steam demand is changing continuously with time. The boiler feed water capacity must vary with the steam demand, but the pressure or head must remain constant, as shown in graph.

Keywords—BFP, VFD, Affinity law, SCADA.

1. INTRODUCTION

Energy cost is a significant factor in economic activity. The imperatives of energy shortage call for energy conservation measures, which essentially means using less amount of energy for the same level of activity. The problem of energy waste is made worse because of many motors are oversized, using more energy than the application actually needs. This is because motors are only available with a certain number of fixed speeds. Users tend to fit the next bigger size relative to the requirement and then throttle the output. Normally, electric motors only have one speed, if one need variable speed need to use different motor for various application and process as required.

2. BOILER FEED PUMP (BFP)

A boiler feed water pump is a specific type of pump used to pump feed water into a steam boiler. Boiler feed pump is used to feed water to steam generator boiler drum at desired pressure and temperature. The water may be freshly supplied or returning condensate produced as a result of the

2.1 Pump Performance Curve:

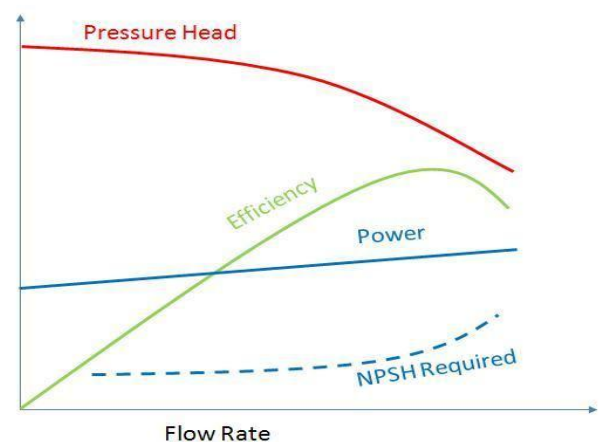

Fig 2. Pump characteristic curve

The increases in discharge flow rate, the discharge pressure decreases. The increases in discharge flow rate, the

discharge pump power consumption increases. The increase in discharge flow rate the pump efficiency first increasing linearly than decreases. NPSH Required: The minimum pressure required at the suction port of the pump to keep the pump from avoiding cavitations.

3. VARIABLE FREQUENCY DRIVE (VFD)

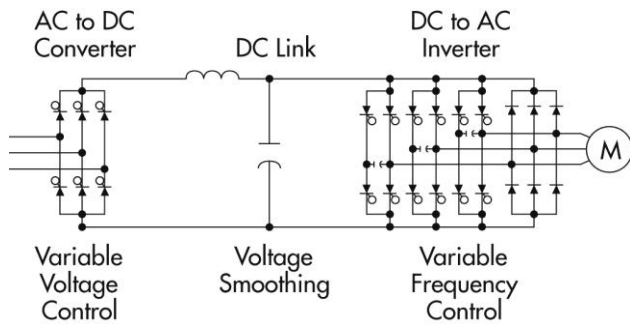

Fig 3. VFD Unit with load

Variable frequency drive is also called variable speed drive(VSD), frequency inverter or AC drive etc. It is an electric device to change utility power source to variable frequency to control AC motor in variable speed operation. The variable frequency drive (VFD) converts the supply frequency and voltage to the required frequency and voltage to drive a motor. Hence, VFD converts the supply frequency and voltage to the frequency and voltage required to drive a motor at a desired speed other than its rated speed.^[2]

3.1 The synchronous speed of an induction motor is given by the equation as:

Motor speed (RPM) is dependent upon frequency.

Varying frequency output of the VFD controls motor speed.

Example:-

$$\text{Speed, } N_s = \text{Frequency (hertz)} \times 120 / \text{no. of poles}$$

2-poles motor at different frequencies

$$3600 \text{ rpm} = 60 \text{ hertz} \times 120 / 2 = 3600$$

$$3000 \text{ rpm} = 50 \text{ hertz} \times 120 / 2 = 3000$$

$$2400 \text{ rpm} = 40 \text{ hertz} \times 120 / 2 = 2400$$

The actual running speed is always lesser by 2 to 6 % of its synchronous speed.

4. BFP FLOW CONTROL

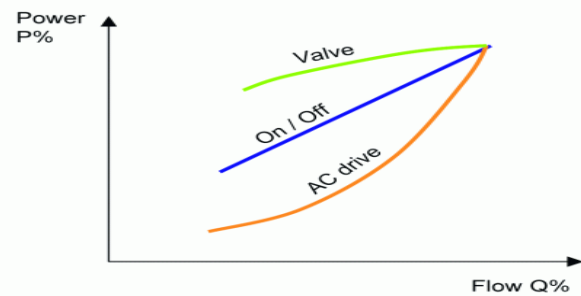

Fig 4. Boiler feed pump flow control curve

Following are the boiler feed control method in boiler house:

On / Off control: In this system the pump starts and stops as per the water level in the water drum.

Feed control valve: In this system boiler drum level is controlled by feed control valve, which is automatically operated by boiler pressure head.

VSD Only: In this system, The boiler drum level is controlled by variable frequency drive, which controls the pump flow rate of the boiler feed pump with constant pressure head. The design discharge pressure must be maintained constant to ensure the water gets to its intended location. As compared to above two methods VSD is efficient controlling and power saving.

Feed control valve and VSD: In this system both feed control valve and VSD are used, to control the flow rate with constant head pressure.

5. POSSIBLE VFD OUTPUT ON INSTALLATION

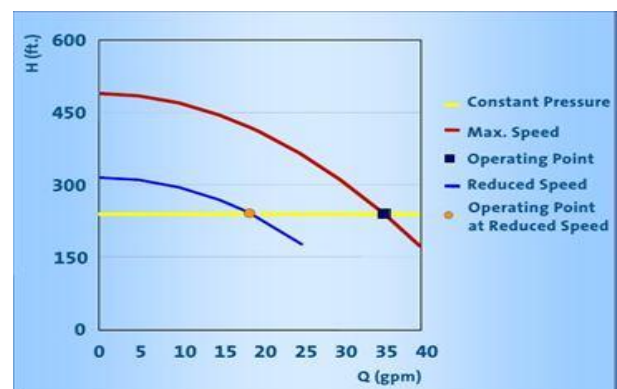

Fig 5. Installation possibility of VFD in BFP

Pump operates only at the speed that is required, that is optimum speed of pump.

Pump speed reduces up to only pinched valve, there is boiler feed pump changed capacity of flow with constant. pressure

head. No pressure loss across the pinched valve. High energy conservation at pinch point.

5.1 Energy saving:

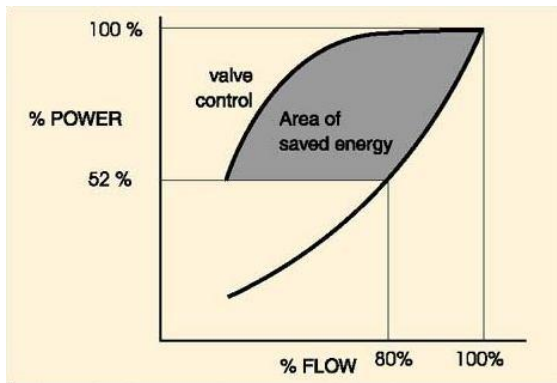

Fig 6. Energy saving with VFD in BFP

The fixed speed motor load application such as the boiler feed pump supplies direct AC power. The energy saving is obtained by variable speed drive by using pump affinity laws. By using a Variable Frequency Drive (VFD) to slow down a pump motor speed from 100% to 80% can save 50% of energy. Reducing pump speed not only reduces energy consumption but also reduces noise and vibration. "A pump or fan running at half speed consumes only one-eighth of the power compared to one running at full speed."^[11]

5.2 VDF Affinity law for BFP:

The affinity laws for pumps/fans are used in plant, hydraulics and HVAC to express the relationship between variables involved in pump or fan performance (such as head, volumetric flow rate, shaft speed and power). They apply to pumps, fans, and hydraulic turbines. In these rotary implements, the affinity laws apply both to centrifugal and axial flows.

Affinity law is based on two type:

1. Changing velocity, keeping diameter constant.
2. Changing diameter, keeping velocity constant.

But changing diameter is not so easy, better change the velocity.

Law 1a. Flow is proportional to shaft speed:

$$\frac{Q_1}{Q_2} = \left(\frac{N_1}{N_2}\right)$$

Law 1b. Pressure or Head is proportional to the square of shaft speed:

$$\frac{H_1}{H_2} = \left(\frac{N_1}{N_2}\right)^2$$

Law 1c. Power is proportional to the cube of shaft speed:

$$\frac{P_1}{P_2} = \left(\frac{N_1}{N_2}\right)^3$$

Where,

- Q is the volumetric flow rate (e.g. CFM, GPM or L/s),
- N is the shaft rotational speed (e.g. rpm),
- H is the pressure or head developed by the fan/pump (e.g. psi or Pascal), and
- P is the shaft power (e.g. W).

The law give the relation between speed which is directly proportional to the flow, sq. root of pressure head, cube root of power.

6. SYSTEM CONTROL

Controlling the whole system is also the main task now a days. Receiving the data from VFD, flow valve manually is not so easy, so we use PLC and SCADA system to get control and receive data.

6.1 Programmable logic control (PLC)

A PLC is a microprocessor-based control system, designed for automation processes in industrial environments. It uses a programmable memory for the internal storage of user-orientated instructions for implementing specific functions such as arithmetic, counting, logic, sequencing, and timing. A PLC can be programmed to sense, activate, and control industrial equipment and, therefore, incorporates a number of I/O points, which allow electrical signals to be interfaced. Input devices and output devices of the process are connected to the PLC and the control program is entered into the PLC memory.^[9]

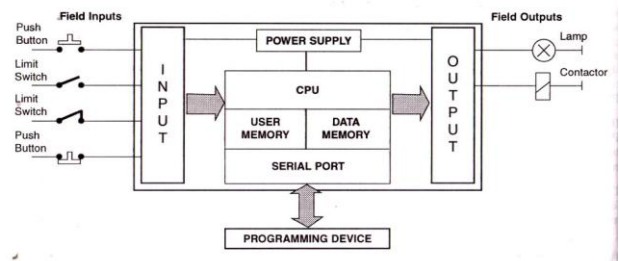

Fig 7. PLC block diagram

In our application, it controls through analog and digital inputs

and outputs the varying load-constant speed operation of an induction motor. Also, the PLC continuously monitors the inputs and activates the outputs according to the control

program. This PLC system is of modular type composed of specific hardware building blocks (modules), which plug directly into a proprietary bus: a central processor unit (CPU), a power supply unit, input-output modules I/O, and a program terminal. Such a modular approach has the advantage that the initial configuration can be expanded for other future applications such as multi-machine systems or computer linking.

SIEMENS PLC will guide all the VFD instructions that will control the motor according to the flow of water from HP drum.

6.2 Supervisory control and data acquisition (SCADA)

SCADA is a system which exercises supervisory control of a particular device from a remote location and the human operator is able to monitor and control the device from his computer screen without being physically present near the device.

A PLC based control system was set up comprising of an SIEMENS PLC, an SIEMENS SINAMICS G120 Variable Frequency Drive, a three-phase induction motor and workstation (personal computer) has been delivered, configured and integrated together for the monitoring and control of a motor driving a conveyor load.

Various control schemes have been used to operate the induction motor in speed and position control modes on operation using PLC programming developed on the workstation.

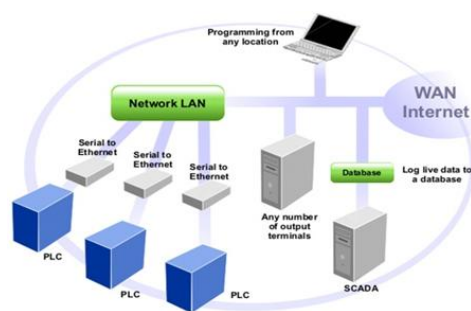

Fig 8. Block diagram of SCADA

SIEMENS energy management with SIMATIC provide SCADA with,^[3]

- Smart decisions – significant saving
- Effective energy controlling

- Increased efficiency
- Energy management with data acquisition.

6.3 Flowchart (process)

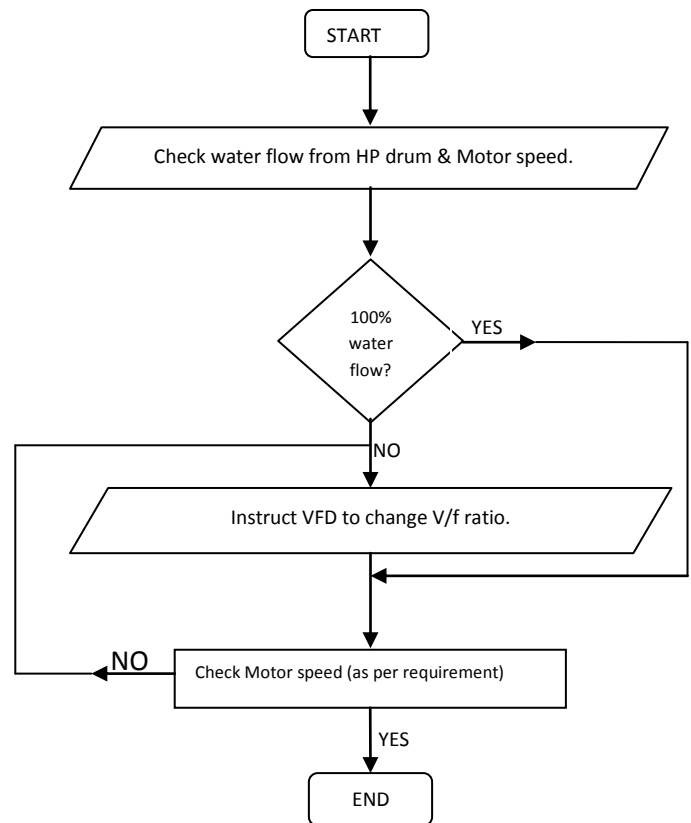

6.4 Operation mechanism.

The PLC will check the reading from flow-meter. If the flow is 100% then the motor need not to be control. But, if flow is reduced below the max. level than gradually the motor speed is to be reduced. So that energy will be saved accordingly. The PLC will instruct the VFD drive to function accordingly and motor speed will be reduced. This data will be displayed on SCADA screen.^[1]

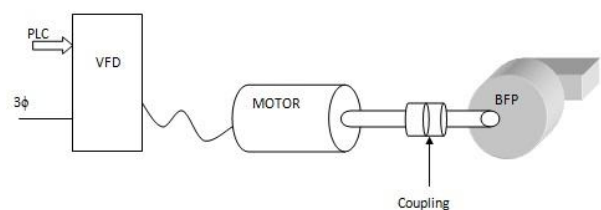

Fig 9. Block diagram basic.

7. ENERGY CONSERVATION

The data obtained from the calculation of the affinity law. It is observed that the using the VFD drive energy is saved upto a great extend. To mathematical values received from the SCADA are manipulated and a graph is designed.

Below slows the graph of flow v/s operating speed of motor and pump working with and without VFD.

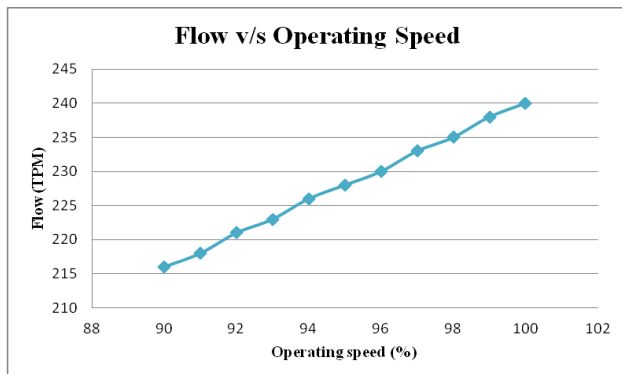

Chart 1. Flow v/s Speed

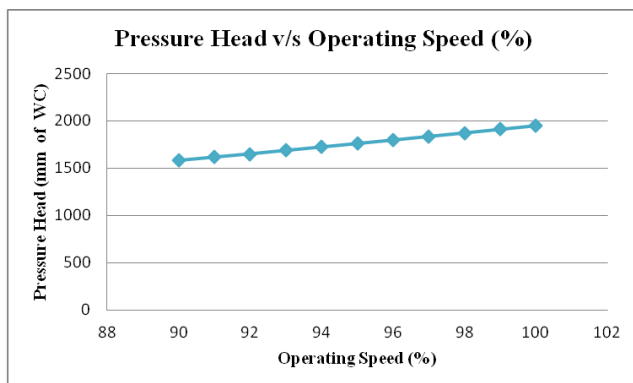

Chart 2. Pressure head Power v/s Pump operating speed in %

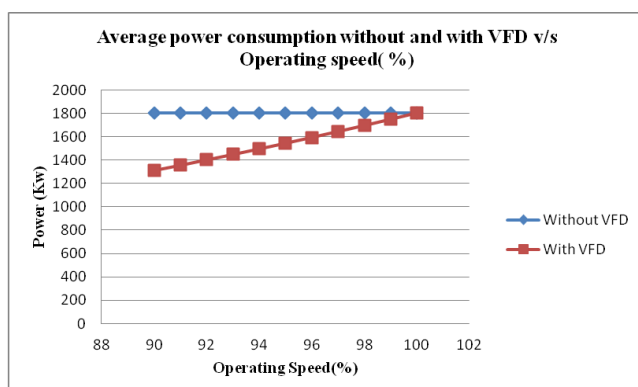

Chart 3. Power without and with VFD v/s Pump operating speed %

From the graph above it is clear seen that energy is saved when VFD is put in action.^[6]

- We can analysis that there is slight decrease in operating speed minor pressure head drop occurs and negligible effect on flow rate.
- The slight decrease rotation speed causes only a small decrease in the pump efficiency compared to operation with fixed revolution and allows a reduction in energy consumption in a wide range of loads.

The average energy saving using VFD per year is 1811172 KWh/yr. Considering per KWh charge of Rs. 3.5. The energy saving per year of Rs. 6,339,102 can be achieved.

8. CONCLUSION

VFD can be installed in boiler feed pump. It can reduce the power consumption by 25% by reducing the 10% operating speed of pump and thereby saves the energy cost. The installation of VFD is not only resulted in energy and cost savings but also avoids operational problems of the plant. Reducing pump speed not only reduces energy consumption but also reduces noise, vibration. This data is saved for future use in SCADA database and comparative study can be done.

ACKNOWLEDGMENT

I would like to thank Prof. Sawankumar Naik for giving his precious time for guiding in this paper. Also my thanks to IMD and Efficiency Dept. of GSECL member for sparing there time in helping me for providing information for paper work.

REFERENCES

- [1] K. Kaviarasu¹, S. Saipadhma², P. Arulmani³ "COMBINATION OF PLC AND VFD BASED AUTOMATIC DETECTION AND RECTIFICATION OF UNDER VOLTAGE PROBLEM IN 3 PHASE INDUCTION MOTOR" Department. of Electrical and Electronics Engineering Thangavelu Engineering College, Chennai, India.
- [2] Mr. Bhavesh Jinjala¹, Prof. Rashmikant. N. Shukla² M.E.[Computer Aided Process Design] Student, Department Of Engineering, L.D. College of Engineering, Ahmedabad, Gujarat, India¹ Principal & Professor In Department Of Chemical Engineering, Government Engineering college, Bharuch, Gujarat, India² "Energy Conservation in Boiler by Variable Speed Drives (VSD)"
- [3] Mr.Priyank Dave¹, Mr.Kashyap Mokariya², Mr.Vijay Patel³ Student, Master of Engineering, Government Engineering College, Valsad, India¹ Assistant Professor,

Government Engineering College, Valsad, India²
Assistant Professor, N.G.Patel Polytechnic, Isroli, India³
“Energy Conservation in centrifugal pump with variable frequency drive including SCADA, PLC and HMI” may 2013

- [4] E. Al-Bassam*, R. Alasseri “ Measurable energy savings of installing variable frequency drives for cooling towers, fans, compared to dual speed motors” Energy and Building Research Center, Kuwait Institute for Scientific Research, Kuwait
- [5] Engin Ozdemir “Energy conservation opportunities with a variable speed controller in a boiler house” Technical Education Faculty, Electrical Education Department, Kocaeli University, 41100 Izmit, Turkey Received 28 July 2003; accepted 15 November 2003
- [6] Rahman SAIDUR ENERGY SAVINGS AND EMISSION REDUCTIONS IN INDUSTRIAL BOILERS By Department of Mechanical Engineering, University of Malaya, Kuala Lumpur, Malaysia.2011
- [7] R. Saidura, S. Mekhilefb, M.B. Alia, A. Safarib, H.A. Mohammedc a Department of Mechanical Engineering, University of Malaya, 50603 Kuala Lumpur, Malaysia b Department of Electrical Engineering, University of Malaya, 50603 Kuala Lumpur, Malaysia c Department of Mechanical Engineering, College of Engineering, Universiti Tenaga Nasional, Km 7, Jalan Kajang-Puchong, 43009 Kajang, Selangor, Malaysia “Application of variable speed drive(VSD) in electrical motors energy saving”
- [8] Ravi Maloth, “Speed Control of Induction Motor Using Fuzzy Logic Controller”, National Conference on Electrical Sciences -2012 (NCES-12) ISBN: 978-93-81583-72-2
- [9] Mohammad Abdul Mannan, Asif Islam, Mohammad Nasir Uddin, Mohammad Kamrul Hassan, Toshiaki Murata, Junji Tamura, “Fuzzy logic based Speed Control of Induction Motor considering core loss into account”, Intelligent Control and Automation, 2012, 3, 229-235, <http://dx.doi.org/10.4236/ica.2012.33026>
- [10] Javadi S., “ Induction Motor Drive Using Fuzzy Logic ” International Conference on Systems Theory and Scientific Computation, Athens, Greece, 24-26, 2007
- [11] Engin Ozdemir “Energy conservation opportunities with a variable speed controller in a boiler house” Technical Education Faculty, Electrical Education Department, Kocaeli University, 41100 Izmit, Turkey Received 28 July 2003; accepted 15 November 2003.
