

AUTOMATIC PHASE CHANGER USING MICRO-CONTROLLER 89C52

Mr.Lalit Patil¹, Shiwali Sonawane², Nisha Thakur³, Komal Nagare⁴

¹Assistant Prof, Dept. of Electronic and Telecommunication, SITRC College, Maharashtra, India

²Under graduate scholar of Dept. of Electronic and Telecommunication, SITRC College, Maharashtra, India

³Under graduate scholar of Dept. of Electronic and Telecommunication, SITRC College, Maharashtra, India

⁴Under graduate scholar of Dept. of Electronic and Telecommunication, SITRC College, Maharashtra, India

Abstract - In three phase equipment's, if supply voltage is low in any of the one phase and you wish to run all the equipment properly. This equipment will help you to rescue this situation. However proper rating fuse need to be used in three phase i.e. R, Y, and B inputs lines. Where the correct voltage is available that time. Other low voltage phase shift to correct voltage in same manner, to run all the equipment on the single phase in the building. The circuit consist of relay comparator, transformer

Key Words: R, Y, B, ATMEL, ADC, PCB

1. INTRODUCTION

Now, in 21st century, fully world is of automation, and it is the time we must think of microcontroller to control. All automatic controller like remote controller, hand held communication devices, automatic and semiautomatic washing machine, automobile indicating and measuring instruments have its application in each.

The project described here being also a microcontroller based project used for automatic phase changer. The use of microcontroller in this project is used to store the data, process data and change data according to the user requirement. This is possible because microcontroller has CPU, memory, I/O ports, timer/counters, ADC/DAC, serial ports, interrupt logic, oscillator circuitry, and many more functional blocks on single chip. Hence it reduces the cost of hardware.

Also there is no need to connect external RAM for memory storage. This is the most important feature of microcontroller. There are various types of microcontroller available in market. The examples are Intel MCS-51, PIC family by microchip, Atmel 89cxx, 89cxx51. The microcontroller used for this project is Atmel 89c52. Now a days many times out of three phases one of the phase cut's off and the circuit breaker trips at that time the MSEB Operator has to operate it manually by turning on the at the time of office hours at that time the hooter shouts and gives us an alert. Keeping in mind the day to day life of human being, the circumstances which occur due to power instability issues we decided to design such a system which

would overcome this issues ultimately and help to reduce human efforts too. Secondly in order to overcome the various phase change issue and avoid damages in industries and automation area plus hospitals & airports

2. LITERATURE SURVEY

The system developed by Steven .M Hietpas "Automatic Voltage Regulator" using ac voltage - voltage convertor which load great flexibility in the voltage regulation for power distribution systems but had high complexity [1]. Then the system named as Automatic Phase Shift Method for finding Detection Of Grid Connected Photo Voltaic inverter in 2003 used photo-voltaic inverter but the statistical analysis were complicated to achieve in single detection [2]. Then the system named as "Grid Current Regulation OF Three Phase Voltage Source Inverter With LC Input Filter" in 2003 may use simple series inductor as the filter interface between VSI and Grid network .But due to harmonic distortion it does not proved to be more advantageous[3]. Then the next system was proposed by Mariuz Malinowkshi named as "Simple Direct Power Control Of Three Phase PWM Rectifier Using Space Vector Modulation(DPC-SVM) in April 2004 but due to variable switching frequency and violation in polarity there was a need to design such a system which would overcome all of above system drawbacks[4].

3. PROBLEM STATEMENT

3.1 SELECTION

In our daily life our focus was to modify the system which can minimize the circumstances or difficulties in person life. In 21st century of modern science and technology there was one thing in mind that to develop a system which can be applied for several application in our daily life. So our concept of automatic phase changer was selected, which can be used in 3 phase application. If there is low voltage in any two phase and want to work all equipment in normal voltage. Our project will solve this problems.

3.2 SOLUTION

There is the switch box which separate the source between MSEB supply and generator. When there is electricity supply from MSEB supply someone goes to change the generator line. And thus the electricity supply restore and off the generator and change the supply line from generator to MSEB supply

As said in solution it reduces the manpower in using energy for starting generator and switching over from public supply

4. BLOCK DIAGRAM

There are three phases R, Y, B which are given to signal conditioning block as shown in fig. 1. The output of the signal conditioning block is given to the analog to digital convertor. This block is used to convert the analog to digital signal which is then pass to the microcontroller 89c52 which is interface with LCD and keyboard. A relay driver circuitry as shown in the fig 1 is mainly the electrically operated switch. The main purpose behind using such a relay circuitry is the complete electrical isolation between input and output, and to control the low power signal. The output of this system is in the form of an electric bulb which glows for the correct output voltage

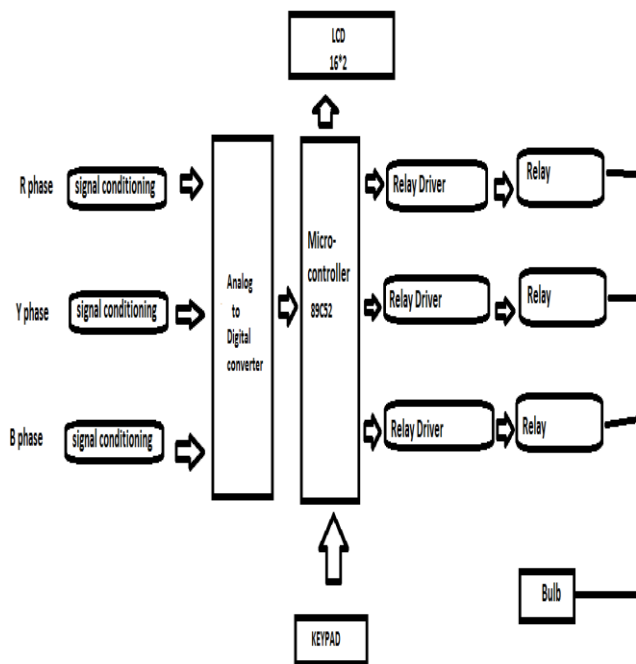

Fig -1: Block Diagram for Automatic Phase Changer.

5. LOGIC ANALYSIS

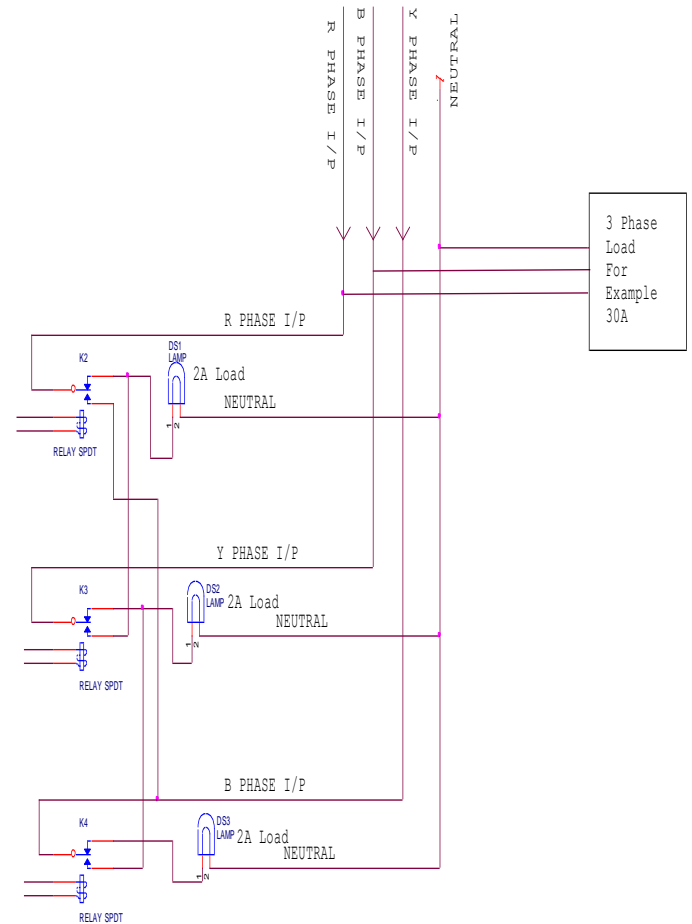

Fig -2: Demonstration of total load.

Total Load = single Phase+ 3 Phase Load

$$\begin{aligned}
 &= R \text{ phase} + Y \text{ Phase} + B \text{ Phase} \\
 &= (2A + 2 A + 2 A) \text{ single Phase} + 30A \\
 &= 36A
 \end{aligned}$$

So each Phase Current is Total Current /3 = 36/3 =12 A

If R phase absent in Normal Condition

Total Load = single Phase+ 3 Phase Load

$$\begin{aligned}
 &= R \text{ phase} + Y \text{ Phase} + B \text{ Phase} + 3 \text{ Phase Load} \\
 &= (0A + 2 A + 2 A) \text{ single Phase} + 0A \\
 &= 4A
 \end{aligned}$$

If R phase absent in Automatic Phase Changer Condition

Total Load = single Phase+ 3 Phase Load

= R phase + Y Phase + B Phase

= (0A + (2 A +2 A) +2A single Phase +

0A (3 Phase)

= 6A is less than 12 A so no problem.

So Maximum Capacity is 12A

CALCULATION OF POWER SUPPLY

There must be some information available in design of transformer

- 1) P_{out}.
- 2) Voltage range.
- 3) Range of operating frequency.
- 4) Value of efficiency and regulation.

1	X	0	0	Single ended.	CH0
1	X	0	1	Single ended.	CH1
1	X	1	0	Single ended.	CH2
1	X	1	1	Single ended.	CH3
0	X	0	0	Differential	CH0=IN+
					CH0=IN-
0	X	0	1	Differential	CH0=IN-
					CH0=IN+
0	X	1	0	Differential	CH2=IN+
					CH3=IN-
0	X	1	1	Differential	CH2=IN-
					CH3=IN+
*D2 is don't care for MCP3204					

Table -1: Value of N/V for 50 Hz freq.

Flux density 0.76 Wb	1.14	1.01	0.98	0.83
N/V 45 / Ain	40/ Ain	40/Ain	Ain/50	55/Ain

Table -2: Configuration Bits for MCP3204.

CONTROL BIT SELECTIONS				I/P CONFIGURATION	CHANNEL SELECTION
SINGLE / DIFF	D2*	D1	D0		

6. RESULT

6.1 OPERATION

The operation starts with converting the 230v, 50Hz AC supply to 12v, 50Hz i.e. step downing the main supply as per the need of the system. Then diodes are used to convert AC to DC 1N4007 which are fully rectified to get pulsating DC but to filter this pulsating signal from the diode. A filter capacitor 1000mf is used to pure DC. Which is given further to the voltage regulator & is also provided to 12v relay which works on DC supply. Regulator 7805 converts 12v to 5v which is given to microcontroller, ADC & LCD display. Microcontroller 89s52 has four ports p1, p2, p3, p4 out of which port is open-line output which contains register bank of 4.7k ohm & has external pull-up & the rest 3port has internal pull-up. Pin no.9 is RESET pin & so power ON RESET (battery) is required which compare of 10mf capacitor&100k ohm register. The register is mounted bellow the IC. Then the crystal oscillator of 11.0592 MHz is used to provide clock pulse to the microcontroller. Along with a 33pf capacitor (2 capacitors of 33pf must).A 100mf decoupling capacitor is used to reduced noise of overall circuitry bellow Microcontroller 89s52 & bellow ADC. Then a power LED above ADC is used to indicate power supply ON/OFF to the circuitry along with a 2.2k ohm

register.12v DC, 70ma current relay along with relay drive circuitry used. Which comprises a transistor DC547 & LED for indication of relay ON/OFF. & 407k ohm resistors are serially attached for LED to limit the current. Then 3 pull-up resistor are used to increase the current of circuitry.(2.2k ohm)IN414 diode are used across relay (RED COLOUR) for freewheeling purposed & to avoid to back emf. And the output of relay LOAD is connected. ADC MCP3204 is 8-channel ADC i.e. we can provide 8 analog input & which will be converted to DC & given for microcontroller.

Output of circuitry is analog so we used ADC & in relay circuitry three different transformer are used. There are three different inputs & each phase has different transformers .A pot is used to set the voltage value & voltage gets divided here (i.e. in relay circuitry of each phase) & the output of voltage divider is provided to the ADC. Similarly each phase output is given to ADC. As the output of transformer is AC so we give the signal to ADC after dividing the voltage. Then the output of ADC is given to microcontroller & then microcontroller decides whether which phase is off & it is display on LED.A 16*2 alphanumeric LED is used i.e. 16 character & alphabetical value & numerical value along with 100ohm resistor which is a current limiting resistor to control the back light. Input pulse are used for manual operation which has a manual switch, R switch, Y switch, B switch to select the phase. Keypad along with switches are connected by strip connector whose output is given directly to the connector through wires soldering.

6.2 OUTPUT

Using three step-down transformer to step down the AC signal which is rectified filtered & then to decrease the voltage so a pot is used which acts as a voltage divider which is given to ADC so that the voltage limit should be 0 to 5v.If we look at LED we get 2-phase as 233v, Y=232 & B=208 phase all 3 are same but we can vary the calibration by the pot on relay circuitry.

On auto mode R-phase is present and after turning the phase OFF it automatically shifts to Y- phase & indications are shown on LED across the block relay across microcontroller. After turning OFF Y- phase & it automatically shifts to B-phase & after turning OFF Y-phase it shows error E (i.e. it's an error and there is no phase) and according after gain of phase is shift to the respective phase. On the keypad there are four buttons out of which the first button for manual / auto-mode and out of manual you can select R,Y,B any of the three in manual phase switchover does not take place as user is selecting the phase only in the auto-mode then the switchover occurs. A bulb is used as a load to indicate phase change at the output.

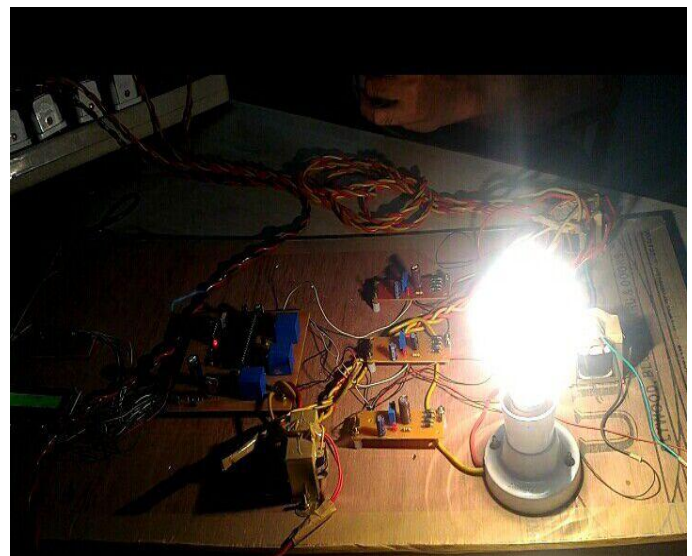
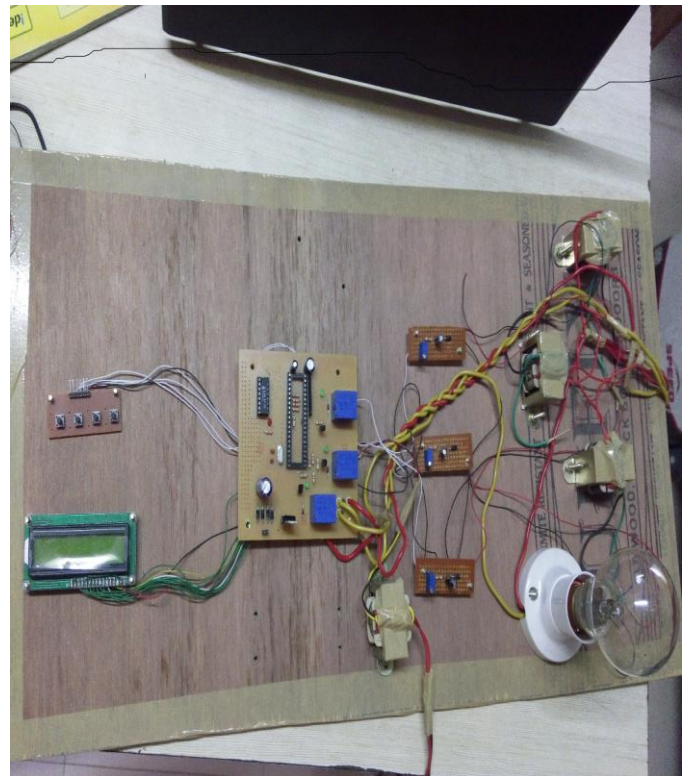

7. ADVANTAGE

No manual errors, Remote location operation can be done, Auto switching of MSEB & DG, PLC with monitor continues input supply and taking automatic decision, Load continues on when MSEB supply is present or not, switching input supply is very fast using PLC.

8. DISADVANTAGE

Costly for general application, this system is not battery operated, Fuel low indication not monitoring, Battery voltage is not displayed on LCD/ 7- segment

9. APPLICATIONS

Here are some application where the controller is been used, like various large processing plants, pharmaceutical industry and also in thermal power station etc.

Here are also some example where huge application been controlled like infrastructure airport and railways. Automatic phase changer is also been used in commercial and service sector .This also reduces the manpower on field

10. CONCLUSION

Hence using this project a correct voltage level at output using same power lines through relay is achieved. In short the control of voltage level at the output of three phase circuitry (i.e. Low level to normal voltage level) can be done. The circuit also provides an automatic phase change in the circuitry (i.e. R, Y, and B). Hence using this circuitry human efforts are reduced and the motive of phase change is achieved automatically with the help of microcontroller which leads to various industrial, medical power plant usages. Moreover the circuit break up issue is also avoided in this project. In short it's an intelligent system which has the ability to monitor, control and switch the system between phases. Avoids power failure from mains without the aid of operator and the switching between mains and the generator access in micro seconds. Ultimately by implementing such a circuit various lives in hospitals can be saved moreover the power failure issue are resolved and in order to complete

REFERENCES

- [1] Steven M. Hietpas, Mark Naden,"Automatic Voltage regulator using an AC Voltage-Voltage Converter," IEEE Transaction on Industrial Application, Vol 36,no 1, January-February 2000.
- [2] Gua-Kiang Hung, Chih- chang Chang, "Automatic Phase Shift Method for Islanding Detection of Grid -Connected Photovoltaic Inverters," IEEE Transaction On Energy conversion, Vol.18.No.1, March 2003.
- [3] Erika Twining, "Grid Current Regulation Of A Three Phase Voltage Source Inverter With an LCL Input Filter," Transaction On Power Electronic, Vol .18, No .3 May 2003.
- [4] Mariusz Malinowski and Jasinski Marek,"Simple Direct Power Control Of Three Phase PWM Rectifier Using Space Vector Modulation (DPC-SVM)," IEEE Transaction on Industrial Electronic , Vol.51,No.2, April 2004