

HELMET WITH ALCOHOL SENSOR

MS Bhodoria¹, Ashish Kumar Gupta², Antra Upadhyaya³, Keshav Kumar⁴, Ekta Shroti⁵

¹Assistant professor, Electronics & Comm. Engg., Institute of information technology and management, Gwalior (MP)

^{2,3,4}Student, Electronics & Comm. Engg., Institute of information technology and management, Gwalior (MP)

Abstract - Nowadays we have seen many road accident and drunken driving cases in our day to day life, especially for two wheelers riders. And the main reason behind this is not wearing helmet. Many people could save their life in accident cases if they were wearing the helmet at the time of accident. So to avoid these accidents a helmet is designed which consists of a limit switch and an MQ3 gas sensor. This project is undertaken to ensure road safety among two wheeler riders. It consists of an RF transmitter, RF receiver, Encoder and Decoder IC. The bike will not start if the rider is not wearing the helmet and it also does not get started if the rider consumes alcohol. When the rider wears the helmet an RF signal is transmitted which is received at the receiver end consisting of RF module receiver in the bike engine which ensures that the rider is wearing the helmet and also about the alcohol consumption by the rider. If any of the conditions are false, then the bike will not get started.

Key Words: Encoder and decoder IC, RF Transmitter and Receiver System, MQ3 Gas sensor.

1. INTRODUCTION

In today's modern life, the craze of motor bikes is increasing in day to day life. In our country, there are majority of people who belong to middle class families and prefer to buy two wheelers over four wheelers. It also suits their budget. The craze of bike among youngsters is increasing day-by-day, especially among college going students. The different sports bikes are introduced by many companies in today's competitive environment. The bikes are increasing on roads heavily, and due to this traffic on the roads is increased. And also the road mishaps are increased day by day, due to which many deaths occur, most of them are caused due to common negligence of not wearing helmet. This motivates us to think about making a system which ensures the safety of bikers, by making it necessary to wear helmet and no consumption of alcohol as per government guidelines. The project aims at the security and safety of bikers, against road accidents. Refusal to use of proper motorcycle helmets is a main factor contributing to the death from road crashes.

So if it is made mandatory for the bikers to wear helmet when they ride the bike then the rates of these accidents can be expected to fall. The circuit is so designed that the bike won't start without wearing helmet.

The helmet described here once installed with any of the bikes forces the rider to wear it while riding, so whether there is any law or not biker will have to wear the helmet ensuring his/her own safety.

The statics of law breaker is depicted below in table.

Table 1:- Statistics of Law Breakers

Law Breakers	Two Wheelers	Four Wheelers
Signal Jumping	2,21,350	1,47,950
Drunken Driving	38,560	18,463

1.1 Objective of the project

The objectives of the project are:-

- I. To design a circuit that can improve the safety of the bike riders.
- II. To design a helmet which ensures no alcohol consumption by the bike rider.
- III. To study and understand the concept of RF transmitter and RF receiver circuit in implementing the project.

2. PRINCIPLE OF OPERATION

The helmet comes with two modules i.e. one receiver and one transmitter. The transmitter being embedded in the helmet, and the receiver module can be installed on any bike. At the transmitter end, the helmet consists of a limit switch and a gas sensor.

3. BLOCK DIAGRAM

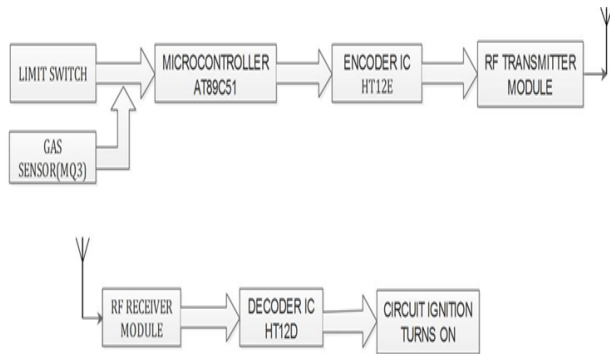

Fig1. Block diagram of a bike incorporating the helmet

In this block diagram it is tried to express that on the transmitter side, the helmet consists of a limit switch which is pressed when the biker wears the helmet. After this, it is checked by the MQ3 gas sensor that whether the biker has consumed alcohol or not. If the biker has not consumed the alcohol, then an RF signal is transmitted through the RF transmitter module towards the receiver end. At the receiving end, the RF receiver module receives the signal and the ignition circuit will be turned on.

4. GAS SENSOR (MQ3)

Sensitive material of MQ3 gas sensor is SnO₂, which has lower conductivity in clean air. When the target alcohol gas exists, the sensor conductivity gets more higher along with the gas concentration rising. MQ3 gas sensor has high sensitivity to alcohol and has good resistance to disturb gasoline, smoke and vapour.



Fig2. MQ3 gas sensor

4.1 Sensitivity Characteristics

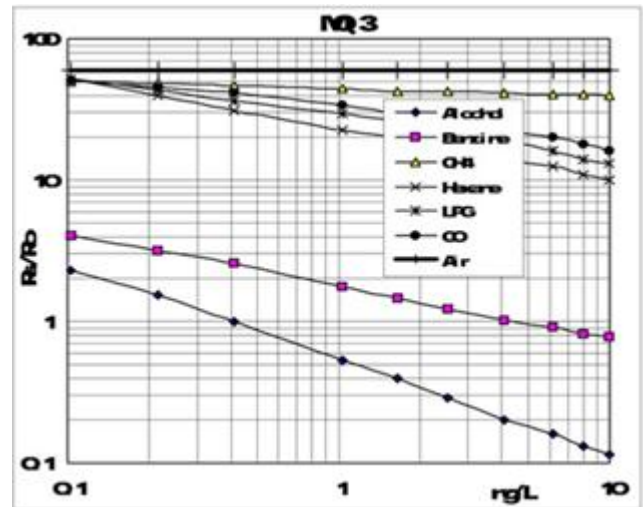
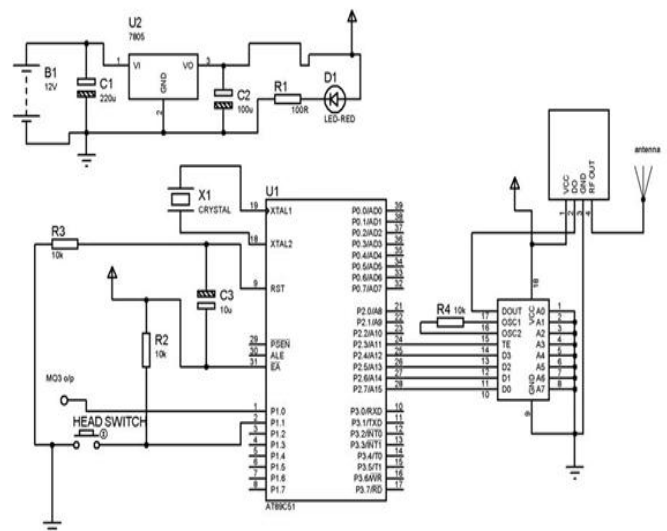

Fig.3 Sensitivity characteristics of MQ3

Ordinate means resistance ratio of the sensor (R_s/R_o), abscissa is concentration of gases. R_s means resistance in different gases, R_o means resistance of sensor in 0.4mg/l alcohol.

5. CIRCUIT DIAGRAM

1. TRANSMITTER CIRCUIT



2. RECEIVER CIRCUIT

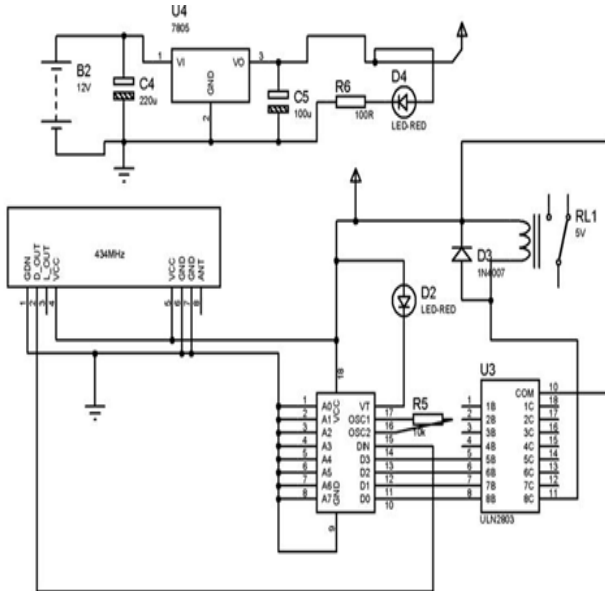

- c. RF Transmitter module receives the signal coming out pin 17 of encoder IC. It consist of four pins namely ground, data in, VCC, ant(transmitting o/p).Through this ant pin the signal is further transmitted to the receiving end.

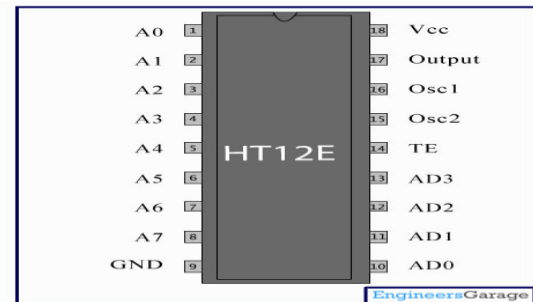

Fig4. Encoder IC

- d. The RF receiver module receives the signal transmitted from the transmitting unit. It consist of 8 pins namely three ground pins, two vcc pins, two pins for data o/p(One for digital data and another for linear data) and the ant pin(receiving i/p).
- e. In simple terms, HT12D converts the serial input into parallel outputs. It decodes the serial addresses and data received by, say, an RF receiver, into parallel data and sends them to output data pins. The serial input data is compared with the local addresses three times continuously. The input data code is decoded when no error or unmatched codes are found. A valid transmission is indicated by a high signal at VT pin and then relay goes on. A string of address and data bit is used to prevent from false triggering. RF receiver module is crystal lock frequency receiver which maintain a constant frequency i.e., 434 MHz due to this variation problem in frequency to be sensed by the receiver can be negotiate.

6. WORKING OF CIRCUIT

- a. When biker wears the helmet, the limit switch attached with the helmet gets pressed and a signal is generated. At the same time, through the mq3 gas sensor it is checked that whether the biker is consuming alcohol or not. If the biker has consumed alcohol then the bike never turns on. But if he doesn't consume alcohol, then a combination of these signals is passed to the microcontroller.
- b. Now in response of the combination of these signals, Encoder IC (HT12E) receives parallel data in the form of address bits and control bits. The control signals from remote switches along with 8 address bits constitute a set of 12 parallel signals. The encoder HT12E encodes these parallel signals into serial bits. Transmission is enabled by providing ground to pin14 which is active low. The control signals are given at pins 10-13 of HT12E. The serial data is fed to the RF transmitter through pin17 of HT12E.

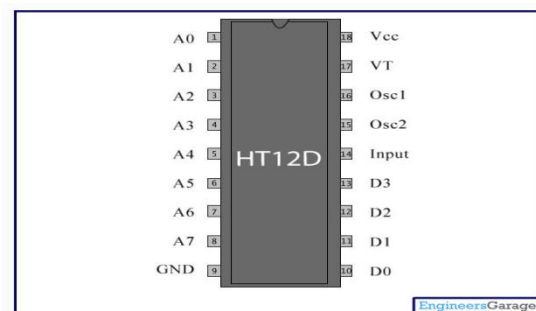

Fig5. Decoder IC

7. APPLICATIONS

- Useful for bike and scooters.
- Help to protect life in accident case.
- Number of cases of violated traffic rules can be reduced.

8. LIMITATIONS

- This circuit works on higher frequencies.
- It is applicable upto a shorter range.

9. CONCLUSION

This project is very effective for bike riders as it ensures their safety. Wearing a helmet not only saves people’s life but also makes them follow the traffic rules. As a result the motorcycle’s engine will start only if the helmet is worn and there is no alcohol consumption. So, it will reduce the impact from accident and can prevent motorcycles from being stolen. And as the project includes wireless system therefore, a rider would not get disturbed by the wire while riding the motorcycle.

10. FUTURE SCOPE

Another type of wireless communication can be used because RF module has some limitations which only provide one way data transmission. Besides, we can add a buzzer in the helmet. By inserting a buzzer in the helmet, the motorcyclist will be more alert and will slow down the motorcycle once they received the signal. The circuit can also be powered by solar energy. GSM Module can also be added for message alert.

11. REFERENCES

[1] The 8051 Microcontroller and Embedded Systems” by Muhammad Ali Mazidi and Janice Gillispie Mazidi, Pearson Education.

[2] “Vehicle accident alert and locator” International Journal of Electrical & Computer Sciences IJECS-IJENS vol: 11 No: 02.

[3] International Journal of Computer Science And Applications Vol. 6, No.2, Apr 2013 ISSN: 0974-1011 (Open Access).

[4] www.electronicsforu.com

[5] www.engineersgarage.com

[6] <http://drivingtest.in/road-accidents-in-india-a-concern.html>

[7] The 8051 Microcontroller and Embedded Systems using assembly and C, Muhammad Ali Mazidi & Janice Gillispie Mazidi.

[8] www.alldatasheets.com





[9] Embedded Systems Design by Arnold S. Berger, 2001.

[10] www.Everything2.com for pressure sensor

[11] Pressure Sensors: Selection and Application by Duane Tandeske.

[12] Wireless Communications by Andreas F. Molisch.

BIOGRAPHIES

	<p>Asst.Prof. MS Bhadoria ECE Dept., IITM Gwalior.</p>
	<p>Mr. Ashish Kumar Gupta ECE Dept., IITM Gwalior. (Final Year Student)</p>
	<p>Ms. Antra Upadhyaya ECE Dept., IITM Gwalior. (Final Year Student)</p>
	<p>Mr. Keshav Kumar ECE Dept., IITM Gwalior. (Final Year Student)</p>
	<p>Ms. Ekta Kumari ECE Dept., IITM Gwalior. (Final Year Student)</p>