

Raspberry Pi Based Patient Monitoring System using Wireless Sensor Nodes

Mendrela Biswas¹, Rupali S. Landge², Bhagyashree A. Mahajan³, Sharada Kore⁴

¹Student, Dept. of Electronics and Telecommunication Engineering, Bharati Vidyapeeth's College of Engineering for Women, Pune, Maharashtra, India

² Student, Dept. of Electronics and Telecommunication Engineering, Bharati Vidyapeeth's College of Engineering for Women, Pune, Maharashtra, India

³ Student, Dept. of Electronics and Telecommunication Engineering, Bharati Vidyapeeth's College of Engineering for Women, Pune, Maharashtra, India

⁴ Professor, Dept. of Electronics and Telecommunication Engineering, Bharati Vidyapeeth's College of Engineering for Women, Pune, Maharashtra, India

Abstract - The monitoring of the patient wirelessly is a major improvement in the medical domain. The micro sensors when integrated into a wireless communication network, helps to remotely collect physiological signals of patient and avoid monitoring using traditional medical instruments which makes the patient tether. In this project, the monitoring of the patient is done by the doctor continuously without actually visiting the patient. Here, we are using various sensors to sense the physiological parameters like temperature, blood pressure [3] ECG and the level of saline. These sensed signals are transmitted to the Raspberry pi to update the data continuously via ADC which will convert these analog signals into digital signals. Through RF transmitter, the data is sent wirelessly to the monitor screen of the doctor. So, the doctor can visualize the patient's data just by sitting in his cabin. When a critical condition occurs, the visual indications will be sent onto the screen.

Key Words: Patient parameters, Sensors, WSN, Remote monitoring, Raspberry pi, RF module.

1. INTRODUCTION

The diagnosis and treatment of patient involves several physiological parameters which needs to be measured on real time basis like temperature, pulse rate, sugar level, Electrocardiogram(ECG), Blood pressure, and most importantly the oxygen level. The wireless sensor that communicates in mesh, collects and transmits some threshold parameter. This increases the efficiency and reliability of this field to a considerable level. Due to the limited resources in medical equipment and its staff, there is a need of a dynamic updating system.

It is not at all easy to supervise a large number of patients at each and every instant. The Doctor has to

visit patient continuously in case of cardiac disease and in Intensive Critical Unit (ICU). In earlier discoveries, the patient were checked and monitored by the monitor screen which was placed near to the patient's bed. But this is more tedious when more number of patients, each time doctor or nurse has to check the readings on monitor screen by visiting the patient.

In our project multiple patients are continuously and simultaneously monitored. Visible alarms are used to indicate the significant event and severe conditions. This will enhance the operational efficiency and also facilitate the early discharge of the patient. This will improve the normal life of patient by reducing the risk of infection and severe condition when the doctor or nurse is not nearby. This project describes the design of a Raspberry Pi based Blood pressure and body temperature measuring device which displays the information on Monitor display. Also ECG and saline level display on the screen. For each parameter, the threshold is decided. The visual warning will be displayed on the monitor screen when the threshold value is exceeded. These signals are displayed on the remote monitor at the doctor's cabin or in the hospital's central room where the monitoring is done. As we are using RF module, its transmitter will send the sensed data from patients bed to the RF receiver at the doctor's cabin will receive the data and will be displayed on the screen. Thus wireless transmission permits the examination of the physiological data of human under normal condition without any discomfort to a person under the investigation. This project consists of simple and low cost components which are capable of processing real time parameters like temperature, Blood Pressure, ECG, level detection of saline.

1.1 System Description

In our system, the data sensed from the patients' WSN is first collected. Since, the data collected is in the analog form, hence, we need to convert it into digital form. The data converted hence is transferred to Raspberry Pi via serial communication. This is then transferred wirelessly to RF transmitter module and then to RF receiver module. Within a span of 5 minutes, the sensed data is stored, transferred and updated in the doctor's monitor continuously. We have also implemented the limitation of various parameters using threshold values based on medical parameters. This value will decide to direct a warning condition through a visual display at the doctors' cabin.

1.2 Components used:

Fig.1 represents the block diagram of the patient monitoring system which consists of following components:

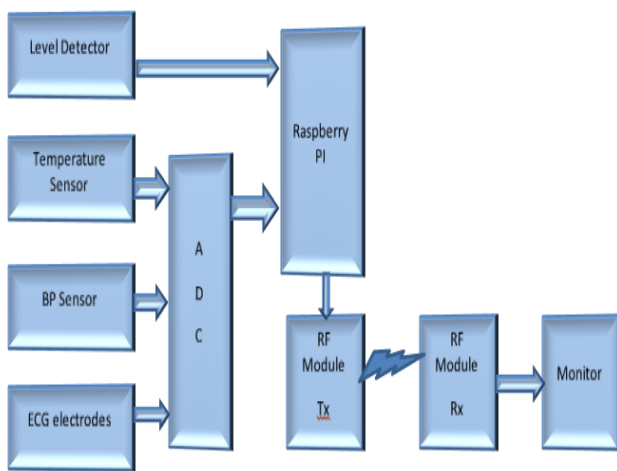

Fig. 1

Raspberry pi: The Raspberry Pi Model B+ incorporates a number of enhancements and new features. Improvement in power consumption, increased connectivity, greater IO are among the major improvements to this powerful, small and lightweight ARM based computer.

Wireless Sensor Nodes (WSN): The wireless sensing nodes are the combination of the sensors and

the drivers which are used to drive the sensed signal from the RF module. Thus RF module acts as the main element in the WSN. In this project, sensors like IR sensor for level detection, temperature sensor like LM35, BP sensor and ECG electrodes are used to sense the signals from the patient and are transferred wirelessly to the monitor.

A) Temperature sensor- LM 35: This sensor used to sense the temperature more accurately having an accuracy of $\pm 0.4^{\circ}\text{C}$ and works on the principal of thermocouple. It has better accuracy than that of the thermistor and does not undergo any oxidation as it is sealed. It does not need amplifying the output voltage. It is an analog type of device. It gives the output voltage proportional to the $^{\circ}\text{C}$ temperature.

B) Blood pressure sensor: The blood pressure sensor measures the systolic and diastolic pressure. It is more reliable than the sphygmomanometer, which makes patient being tether during checking.

C) Level Detector: IR sensor is placed at the threshold level of the saline bottle. When the solution in the bottle drops at this threshold, it will be sensed by the sensor and the logic 1 will be sent to the Raspberry Pi and alert the doctor about it. So it will avoid the risk of back flow of blood of the patient to saline bottle when it is finished.

D) ECG electrodes: Generally there are 12 electrodes which are applied on a patient's body to get the ECG signal but in this project we are using only 3 electrodes which are applied on chest which will sense the heartbeat rate and generate the ECG signal. This will be better for patient as it avoids the use of a large no of electrodes on the body that feels them like tethered by the wires.

E) RF module: It is used in WSN for wireless transmission. It has two modules transmitter and receiver. The transmitter is present at the sensor side which helps to transmit the signal towards the monitor at receiver side. The receiver module is present in the doctor's cabin or in the control room which will receive the signal from the transmitter wirelessly. It is wireless personal area network. In particular, we are using mesh connection that help us to apply more than one signal at a time. It is smaller in

size. It is less power consuming device.

Analog to digital converter (ADC):ADC0809 is an 8 channel 8 bit ADC having SPI serial interface. It is compatible with Raspberry pi model B. It has less power consumption capability of 15mW. It works on the successive approximation technique. As it is mainly used for sensors interfacing and low power CMOS technology makes it perfect for our project.

Software Requirements

Python programming: It is the language which can be interpreted very easily i.e. can be read and write. As it is platform independent, has vast libraries and supported by the Raspberry Pi, thus making it suitable for our project.

MATLAB: It is used to display the list of parameters and its values on the monitor screen and also the updated values at each and every time. Its coding is easy and can be modified easily and efficiently.

2. RESULT

From fig. 2, we can see the result of our system in the GUI(Graphical User Interface) as shown in it. The values from the WSN are displayed on the monitor screen. Our GUI displays following parameters- Body temperature which is in degree Celsius, Saline bottle level which will display either empty or OK depending on the threshold value, and the others- Blood Pressure and ECG will also be displayed.

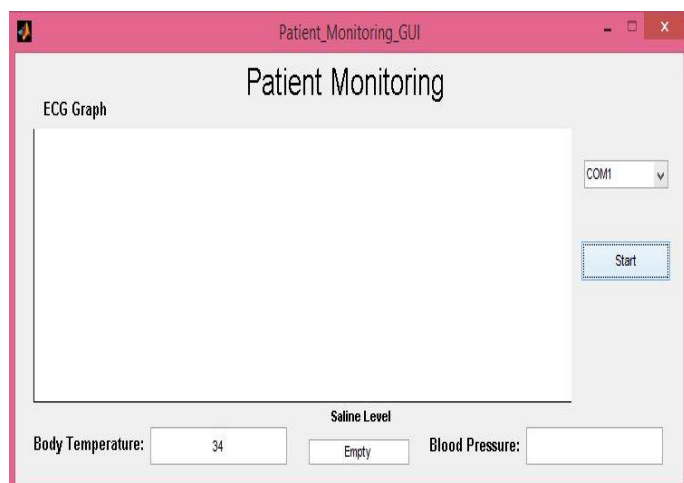

Fig. 2

3. CONCLUSIONS

The advantages of our system are that we can monitor our patient wirelessly and there is no need to check them by physically as all the data is updated on to the doctors monitor after certain interval of time. Also, as LAN is used, the doctor can monitor patient from anywhere within the hospital premises. Thus, the actual treatment at correct time can be given especially while giving Saline to a patient as it's a critical when level of saline in bottle is below a certain level. Programming is easier in Raspberry Pi and also for future modification in the PI.

Our system limitations are that it can be monitored only in the premises as we are using LAN. Accuracy of output is less in ECG.

The applications are vivid likewise, as the patients data are being updated and saved periodically. Hence, by replacing LAN with WAN, we can connect to all the other branches of the concerned hospital and thus the critical patients data can be sent and observed for better treatment.

Hence, in our paper, we have implemented the wirelessly monitoring system for patients using WSN-Temperature Sensor, Level Detector, BP sensors and ECG electrodes. Thus, data sensed by sensor which is sent wirelessly via WSN. The data is updated using Raspberry PI.

REFERENCES

- [1] C.C.Gavimath, Krishnamurthy Bhat, C.L. Chayalakshmi, R. S. Hooli and B.E.Ravishankera, "Design and Development of versatile saline flow rate measuring system and GSM based remote monitoring device", International Journal of Pharmaceutical Applications ISSN 0976-2639. Vol 3, Issue 1,2012, pp 277-281
- [2] Ch. Sandeep Kumar Subudhi and S. Sivanandam, "Intelligent Wireless Patient Monitoring and Tracking System(Using Sensor Network and Wireless Communication)", International Journal of Interdisciplinary and Multidisciplinary Studies,2014,Vol 1,No.3,97-104
- [3] Ravi MS and K V Muralidhar, "Raspberry PI based Data Sensing and Logging System using WSN and

LAN”, International Journal of Engineering Research & Technology (IJERT) ISSN: 2278-0181 Vol. 4 Issue 05, May-2015

[4] Josie Hughes, Jize Yan and Kenichi Soga, “Development of wireless sensor network using Bluetooth Low Energy(BLE) for construction noise monitoring”, International Journal on Smart Sensing and Intelligent System Vol. 8 No. 2, June 2015

[5] Shouling Ji, Student Member, IEEE, Raheem Beyah, Senior Member, IEEE, and Zhipeng Cai, Member, IEEE, “Snapshot and Continuous Data Collection in Probabilistic Wireless Sensor Networks”.