

# AN EXTENSIVE COMPARISON OF EXISTING AND EMERGING WIRELESS TECHNOLOGY (WI-FI, WIMAX, GI-FI AND LI-FI)

**\*<sup>1</sup>Mrs. Gayatri .S, \*<sup>2</sup>Dr.Arutchelvan G.**

*\*<sup>1</sup>M.Phil Research Scholar, Department of Computer Science Adhiparasakthi College of Arts and Science, Kalavai, TamilNadu, India.*

*\*<sup>2</sup>M.Phil Guide, Department of Computer Science Adhiparasakthi College of Arts and Science, Kalavai, TamilNadu, India.*

-----\*\*\*-----

**Abstract** - *The explosive growth of internet over last decade has led to an increasing demand for high-speed, ubiquitous Internet access. Using open broadband wireless technologies and implementing mobile computing architectures, one can overcome the challenges of ground, infrastructure and finance to increase access. As the technology evolves to address portable and mobile applications, the required features and performance of the system will increase. The Wimax is 100 times faster than Wi-Fi which is generally used in business purpose. Whether the Wi-max worked in microwave interoperability in Post Wi-Fi technology, the light fidelity (Li-Fi) can be complemented of RF communication and subset of visible light communication LIFI is 1000 times faster than Wi-Fi and much efficient than WIMAX. Li-Fi and Gigabyte Fidelity (Gi-Fi) technologies are not allowed to used in the daily life just because these two technologies are operated in 10m light communicating ranges. This paper presents a description of the existing and emerging wireless technologies Wi-Fi, Wi-Max, Gi-Fi and Li-Fi find out the best technology, we should take care some parameter like efficiency, easy technology, low cost and easy to operate and find out the best among them, which will be the future choice in communication industry.*

**Key Words:** *Ontology Learning, Web Services Annotation, NLP, WiMax, LiFi, Gi-Fi, wireless Technologies,*

## I. INTRODUCTION

With the help of many expert communication engineers IEEE has developed various wireless standards in a hierarchical fashion. Some of the deployed wireless standards are 802.11(Wi-Fi), 802.16(WiMAX), 802.15.3c (Gi-Fi). Recently a new standard 802.15.7 (Li-Fi) has been proposed and which is still under development. Each of these IEEE standards has been deployed to fulfil certain

criteria and they complement each other. The first Wi-Fi-enabled devices were introduced in 1997. For the first time, we were liberated from a physical Internet connection and free to move about the room, while maintaining connectivity. With this new found freedom came an extraordinary expansion of uses.

Over the years, Wi-Fi has become ubiquitous on laptop computers, tablets, televisions, video game consoles, and smart phones. Worldwide Interoperability for Microwave Access (Wi-MAX) is a wireless communications technology aiming to provide wireless data over long distances in a variety of ways. The new emerging technologies gi-fi and li-fi have included special features to provide faster data transfer in low cost and also with better security.

The purpose of this paper is to provide a technical and market comparison of Wi-Fi, WiMAX, Gi-fi and Li-fi technologies in order to highlight that which technology will be better to build a wireless access infrastructure. The first part of the paper examines all of these wireless technologies in order to understand all technologies and their underlying concepts. Then, we have discussed some key characteristics to compare all these technologies. The last part concludes and presents a conclusion of which will be the best technology to build a wireless access infrastructure.

### 1.1 Problem Statement

Increased use of mobile devices within the organization, and increase in worker mobility, has fuelled the demand for wireless networks. Wireless technology is a patchwork of incompatible systems. Initially, the technology was slow, expensive and reserved for mobile situations or hostile environments, where cabling was impractical or impossible. With the maturing of industry standards and the deployment of lightweight wireless devices alter the need of hardware-software co-design to overcome the problems of present wireless scenario.

Wireless technology has come of age, which enables two or more computers to communicate using standard

network protocols. Wireless networking does not require any fixed infrastructure and cabling. This technology is propelled the emergence of cross-vendor industry standards such as IEEE 802.11, IEEE 802.15 and IEEE.802.16. This technology has produced a number of affordable wireless solutions that are growing in popularity with the organizations for sophisticated applications, where more mobility is required. This will comprise most of the recent wireless technologies that are in use.



**Figure 2.1: Wireless Devices**

**II LITERATURE REVIEW**

A wireless network enables people to communicate and access applications and information without wires. This provides freedom of movement and the ability to extend applications to different parts of a building, city, or nearly anywhere in the world. Wireless networks allow people to interact with e-mail or browse the Internet from a location that they prefer many types of wireless communication systems exist, but a distinguishing attribute of a wireless network is that communication takes place between computer devices. These devices include personal digital assistants (PDAs), laptops, personal computers (PCs), servers, and printers. Computer devices have processors, memory, and a means of interfacing with a particular type of network. Traditional cell phones don't fall within the definition of a computer device; however, newer phones and even audio headsets are beginning to incorporate computing power and network adapters. Eventually, most electronics will offer wireless network connections.

As with networks based on wire, or optical fiber, wireless networks convey information between computer devices. The information can take the form of e-mail messages, web pages, and database records, streaming video or voice. In most cases, wireless networks transfer data, such as e-mail messages and files, but advancements in the performance of wireless networks is enabling support for video and voice communications as well. Wireless means transmitting signals using radio waves as the medium instead of wires. Wireless technologies are used for tasks as simple as switching off the television or as complex as supplying the sales force with information from an automated enterprise application while in the field. Now cordless keyboards and mice, PDAs, pagers and digital and cellular phones have become part of our daily life.

**2.1 Wireless Network Topologies**

There are basically three ways to set up a wireless network

**a) Point-To-Point Bridge**

As you know, a bridge is used to connect two networks. A point-to-point bridge interconnects two buildings having different networks. For example, a wireless LAN bridge can interface with an Ethernet network directly to a particular access point (as shown in the following image).

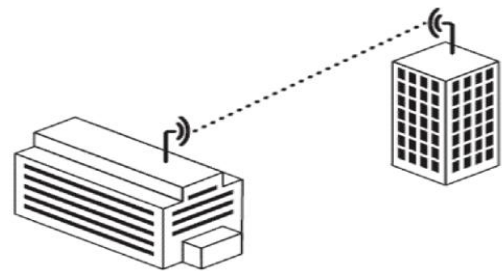

**Figure 2.2: Point-to-Point Bridge**

**b) Point-To-Multipoint Bridge**

This topology is used to connect three or more LANs that may be located on different floors in a building or across buildings (as shown in the following image).

**c) Mesh or Ad Hoc Network**

This network is an independent local area network that is not connected to a wired infrastructure and in which all stations are connected directly to one another (as shown in the following image).

**2.2 Types of Wireless Networks**

Wireless technologies can be classified in different ways depending on their range. Each wireless technology is designed to serve a specific usage segment. The requirements for each usage segment are based on a variety of variables, including Bandwidth needs, Distance needs and Power.

**a) Wireless Wide Area Network (WWAN)**

This network enables you to access the Internet via a wireless wide area network (WWAN) access card and a

PDA or laptop. These networks provide a very fast data speed compared with the data rates of mobile telecommunications technology, and their range is also extensive. Cellular and mobile networks based on CDMA and GSM are good examples of WWAN.

**b) Wireless Personal Area Network (WPAN)**

These networks are very similar to WWAN except their range is very limited. A wireless personal area network (WPAN) is a type of personal network that uses wireless communication technologies to communicate and transfer data between the user’s connected devices. It allows an individual to connect all or most of his or her devices together and access the Internet or a local network using any of the native/supported wireless communication techniques.

**c) Wireless Local Area Network (WLAN)**

This network enables you to access the Internet in localized hotspots via a wireless local area network (WLAN) access card and a PDA or laptop. It is a type of local area network that uses high-frequency radio waves rather than wires to communicate between nodes.

**d) Wireless Metropolitan Area Network (WMAN)**

This network enables you to access the Internet and multimedia streaming services via a wireless region area network (WRAN). These networks provide a very fast data speed compared with the data rates of mobile telecommunication technology as well as other wireless network, and their range is also extensive.

**Standards for WMANs**

There are currently three different standards being researched and produced to support WMANs:

1. Hiper MAN
2. Hiper ACCESS
3. 802.16

A wireless access point (WAP) connects a group of wireless devices to an adjacent wired LAN. An access point resembles a network hub, relaying data between connected wireless devices in addition to a (usually) single connected wired device, most often an Ethernet hub or switch, allowing wireless devices to communicate with other wired devices. Wireless adapters allow devices to connect to a wireless network. These adapters connect to devices using various external or internal interconnects such as PCI, miniPCI, USB, Express Card, Card bus and PC

Card. As of 2010, most new laptop computers come equipped with built in internal adapters.

**Comparison of Wireless Network Types**

Type	Coverage	Performance	Standards	Applications
WPAN	Within reach of a person	Moderate	Bluetooth, IEEE 802.15, and IrDa	Cable replacement for peripherals
WLAN	Within a Building or campus	High	IEEE 802.11, Wi-Fi and HiperLAN	Mobile extension of wired networks
WMAN	Within a City	High	IEEE 802.16, And WIMAX	Fixed wireless between homes and businesses and the Internet
WWAN	World wide	Low	CDPD and Cellular 2G,2.5G and 3G	Mobile access to the internet from Outdoor areas

**Table 2.1 Wireless Network Types**

**III Wi-Fi TECHNOLOGY**

Wi-Fi is a technology that allows electronic devices to connect to a wireless LAN (WLAN) network, mainly using the 2.4 gigahertz (12 cm) UHF and 5 gigahertz (6 cm) SHF ISM radio bands. A WLAN is usually password protected, but may be open, which allows any device within its range to access the resources of the WLAN network.

The Wi-Fi Alliance defines Wi-Fi as any "wireless local area network" (WLAN) product based on the Institute of Electrical and Electronics Engineers' (IEEE) 802.11 standards. However, the term "Wi-Fi" is used in general English as a synonym for "WLAN" since most modern WLANs are based on these standards. "Wi-Fi" is a trademark of the Wi-Fi Alliance. The "Wi-Fi Certified" trademark can only be used by Wi-Fi products that successfully complete Wi-Fi Alliance interoperability certification testing.

Devices which can use Wi-Fi technology include personal computers, video-game consoles, smart phones, digital cameras, tablet computers and digital audio players. Wi-Fi compatible devices can connect to the Internet via a WLAN network and a wireless access point. Such an access point (or hotspot) has a range of about 20 meters (66 feet) indoors and a greater range outdoors. Hotspot coverage can be as small as a single room with walls that block radio waves, or as large as many square kilometres achieved by using multiple overlapping access points. Wi-Fi is less secure than wired connections, such as Ethernet, precisely because an intruder does not need a physical connection. Web pages that use TLS are secure, but unencrypted internet access can easily be detected by intruders.



### Etymology of Wi-Fi

The term Wi-Fi, commercially used at least as early as August 1999, was coined by brand-consulting firm Interbrand Corporation. The Wi-Fi Alliance had hired Interbrand to determine a name that was "a little catchier than 'IEEE 802.11b Direct Sequence'". Phil Belanger, a founding member of the Wi-Fi Alliance who presided over the selection of the name "Wi-Fi", also stated that Interbrand invented Wi-Fi as a play on words with hi-fi, and also created the Wi-Fi logo. The Wi-Fi Alliance used the "nonsense" advertising slogan "The Standard for Wireless Fidelity" for a short time after the brand name was invented, leading to the misconception that Wi-Fi was an abbreviation of "Wireless Fidelity".

The yin-yang Wi-Fi logo indicates the certification of a product for interoperability. Non-Wi-Fi technologies intended for fixed points, such as Motorola Canopy, are usually described as fixed wireless. Alternative wireless technologies include mobile phone standards, such as 2G, 3G, 4G or LTE. The name is often written as Wi-Fi or Wifi, but these are not approved by the Wi-Fi Alliance.



Figure 3.1: The Wi-Fi Network

### 3.4 Wi-Fi Certification

The IEEE does not test equipment for compliance with their standards. The non-profit Wi-Fi Alliance was formed in 1999 to fill this void — to establish and enforce standards for interoperability and backward compatibility, and to promote wireless local-area-network technology. As of 2010, the Wi-Fi Alliance consisted of more than 375 companies from around the world. The Wi-Fi Alliance enforces the use of the Wi-Fi brand to technologies based on the IEEE 802.11 standards from the IEEE. This includes wireless local area network (WLAN) connections, device to device connectivity (such as Wi-Fi Peer to Peer aka Wi-Fi Direct), Personal area network (PAN), local area network (LAN) and even some limited wide area network (WAN) connections.

### 3.5 IEEE 802.11 STANDARD

The IEEE 802.11 standard is a set of media access control (MAC) and physical layer (PHY) specifications for implementing wireless local area network (WLAN) computer communication in the 2.4, 3.6, 5, and 60 GHz frequency bands. They are created and maintained by the IEEE LAN/MAN Standards Committee (IEEE 802). The base version of the standard was released in 1997, and has had subsequent amendments. The standard and amendments provide the basis for wireless network products using the Wi-Fi brand.

### 3.6 Uses of Wi-Fi

To connect to a Wi-Fi LAN, a computer has to be equipped with a wireless network interface controller. The combination of computer and interface controller is called a station. For all stations that share a single radio frequency communication channel, transmissions on this channel are received by all stations within range. The transmission is not guaranteed to be delivered and is therefore a best-effort delivery mechanism. A carrier wave is used to transmit the data. The data is organized in packets on an Ethernet link, referred to as "Ethernet frames"

### 3.7 Wi-Fi Radio Spectrum

802.11b and 802.11g use the 2.4 GHz ISM band, operating in the United States under Part 15 Rules and Regulations. Because of this choice of frequency band, 802.11b and 802.11g equipment may occasionally suffer interference from microwave ovens, cordless telephones, and Bluetooth devices.

### 3.8 Interference

Wi-Fi connections can be disrupted or the internet speed lowered by having other devices in the same area. Many 2.4 GHz 802.11b and 802.11g access-points default to the same channel on initial start up, contributing to congestion on certain channels. Wi-Fi pollution, or an excessive number of access points in the area, especially on the neighboring channel, can prevent access and interfere with other devices' use of other access points, caused by overlapping channels in the 802.11g/b spectrum, as well as with decreased signal (SNR) between access points. This can become a problem in high-density areas, such as large apartment complexes or office buildings with many Wi-Fi access points. It is advised to only use channel 1-6-11.

### 3.9 Service set identifier (SSID)

In addition to running on different channels, multiple Wi-Fi networks can share channels. A service set is the set of all the devices associated with a particular Wi-Fi network. The service set can be local, independent, extended or mesh.

### 3.10 Throughput

As the 802.11 specifications evolved to support higher throughput, the bandwidth requirements also increased to support them. 802.11n uses double the radio spectrum/bandwidth (40 MHz) compared to 802.11a or 802.11g (20 MHz). This means there can be only one 802.11n network on the 2.4 GHz band at a given location, without interference to/from other WLAN traffic. 802.11n can also be set to limit itself to 20 MHz bandwidth to prevent interference in dense community.

## IV THE WIMAX

**WiMAX (Worldwide Interoperability for Microwave Access)** is a family of wireless communications standards initially designed to provide 30 to 40 megabit-per-second data rates, with the 2011 update providing up to 1 Gbit/s for fixed stations. The name "WiMAX" was created by the **WiMAX Forum**, which was formed in June 2001 to promote conformity and interoperability of the standard. The forum describes WiMAX as "a standards-based technology enabling the delivery of last mile wireless broadband access as an alternative to cable and DSL". IEEE 802.16m or Wireless MAN-Advanced is a candidate for the 4G, in competition with the LTE Advanced standard.

WiMAX refers to interoperable implementations of the IEEE 802.16 family of wireless-networks standards ratified by the WiMAX Forum. (Similarly, Wi-Fi refers to interoperable implementations of the IEEE 802.11 Wireless LAN standards certified by the Wi-Fi Alliance.) WiMAX Forum certification allows vendors to sell fixed or mobile products as WiMAX certified, thus ensuring a level of interoperability with other certified products, as long as they fit the same profile. The original IEEE 802.16 standard (now called "Fixed WiMAX") was published in 2001. WiMAX adopted some of its technology from WiBro, a service marketed in Korea.

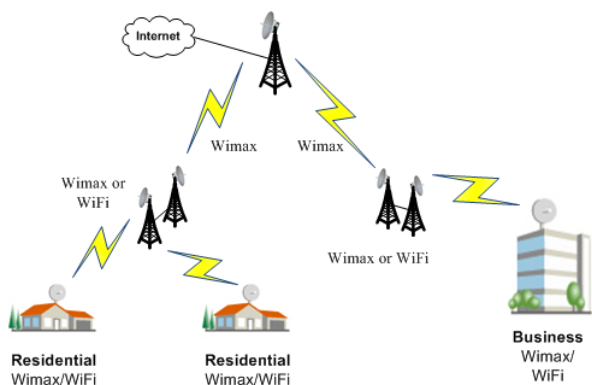

Figure 4.1: The WiMAX Network

### 4.1 Development

The IEEE 802.16m-2011 standard was the core technology for WiMAX 2. The IEEE 802.16m standard was submitted to the ITU for IMT-Advanced standardization. IEEE 802.16m is one of the major candidates for IMT-Advanced technologies by ITU. Among many enhancements, IEEE 802.16m systems can provide four times faster data speed than the WiMAX Release 1.

WiMAX Release 2 provided backward compatibility with Release 1. WiMAX operators could migrate from release 1 to release 2 by upgrading channel cards or software. The WiMAX 2 Collaboration Initiative was formed to help this transition.

### 4.2 Uses Of WiMAX

The bandwidth and range of WiMAX make it suitable for the following potential applications:

- Providing portable mobile broadband connectivity across cities and countries through a variety of devices.
- Providing a wireless alternative to cable and digital subscriber line (DSL) for "last mile" broadband access.
- Providing data, telecommunications (VoIP) and IPTV services (triple play).
- Providing a source of Internet connectivity as part of a business continuity plan.
- Smart grids and metering

### 4.3 Internet access

WiMAX can provide at-home or mobile Internet access across whole cities or countries. In many cases this has resulted in competition in markets which typically only had access through an existing incumbent DSL (or similar) operator.

Additionally, given the relatively low costs associated with the deployment of a WiMAX network (in comparison with 3G, HSDPA, xDSL, HFC or FTTx), it is now economically viable to provide last-mile broadband Internet access in remote locations

### 4.4 Connecting WiMAX



Figure 4.2 A WiMAX USB modem for mobile access to the Internet

Devices that provide connectivity to a WiMAX network are known as subscriber stations (SS). Portable units include

handsets (similar to cellular smart phones ); PC peripherals (PC Cards or USB dongles); and embedded devices in laptops, which are now available for Wi-Fi services. In addition, there is much emphasis by operators on consumer electronics devices such as Gaming consoles, MP3 players and similar devices. WiMAX is more similar to Wi-Fi than to other 3G cellular technologies.

#### 4.5 Gateways

WiMAX gateway devices are available as both indoor and outdoor versions from several manufacturers including VecimaNetworks, Alvarion, Airspan, ZyXEL, Hua wei, and Motorola. The list of deployed WiMAX networks and WiMAX Forum membership list [10] provide more links to specific vendors, products and installations. The list of vendors and networks is not comprehensive and is not intended as an endorsement of these companies above others.

#### 4.6 External modems

USB can provide connectivity to a WiMAX network through what is called a dongle. Generally these devices are connected to a notebook or net book computer. Dongles typically have directional antennas which are of lower gain compared to other devices. As such these devices are best used in areas of good coverage.

#### 4.7 Mobile phones

HTC announced the first WiMAX enabled mobile phone, the Max 4G, on November 12, 2008.[11] The device was only available to certain markets in Russia on the Yota network.

#### 4.8 WiMAX Forum Architecture

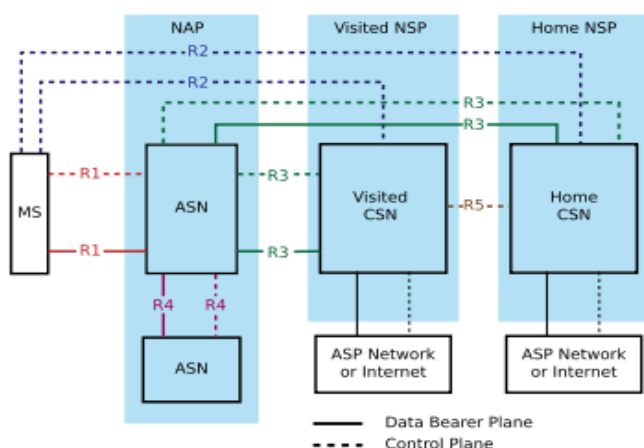

Figure 4.3: WiMAX Forum Architecture

The WiMAX Forum has proposed an architecture that defines how a WiMAX network can be connected with an IP based core network, which is typically chosen by operators that serve as Internet Service Providers (ISP);

Nevertheless, the WiMAX BS provide seamless integration capabilities with other types of architectures as with packet switched Mobile Networks.

- **SS/MS:** the Subscriber Station/Mobile Station
- **ASN:** the Access Service Network
- **BS:** Base station, part of the ASN
- **ASN-GW:** the ASN Gateway, part of the ASN
- **CSN:** the Connectivity Service Network
- **HA:** Home Agent, part of the CSN
- **AAA:**Authentication, Authorization and Accounting Server, part of the CSN
- **NAP:** a Network Access Provider
- **NSP:** a Network Service Provide

#### 4.9 Spectrum Allocation

There is no uniform global licensed spectrum for WiMAX, however the WiMAX Forum has published three licensed spectrum profiles: 2.3 GHz, 2.5 GHz and 3.5 GHz, in an effort to drive standardization and decrease cost. In the USA, the biggest segment available is around 2.5 GHz, and is already assigned, primarily to Sprint Nextel and Clear wire. Elsewhere in the world, the most-likely bands used will be the Forum approved ones, with 2.3 GHz probably being most important in Asia. Some countries in Asia like India and Indonesia will use a mix of 2.5 GHz, 3.3 GHz and other frequencies. Pakistan's Wateen Telecom uses 3.5 GHz.

#### 4.10 Limitations of WiMAX

WiMAX cannot deliver 70 Mbit/s over 50 km (31 mi). Like all wireless technologies, WiMAX can operate at higher bitrates or over longer distances but not both. Operating at the maximum range of 50 km (31 mi) increases bit error rate and thus results in a much lower bit rate. Conversely, reducing the range (to under 1 km) allows a device to operate at higher bitrates. A city-wide deployment of WiMAX in Perth, Australia demonstrated that customers at the cell-edge with an indoor Customer-premises equipment (CPE) typically obtain speeds of around 1-4 Mbit/s, with users closer to the cell site obtaining speeds of up to 30 Mbit/s.

#### 4.11 Competing Technologies

Within the marketplace, WiMAX's main competition came from existing, widely deployed wireless systems such as Universal Mobile Telecommunications System (UMTS),CDMA2000, existing Wi-Fi and mesh networking.



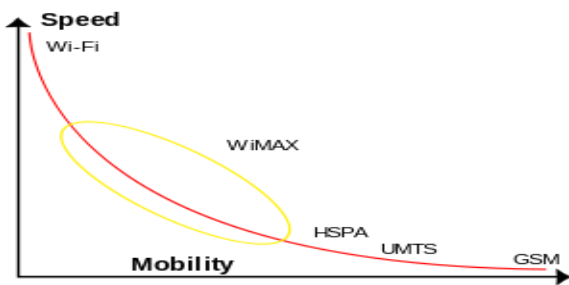

**Figure 4.4: Speed vs. mobility of wireless systems: Wi-Fi, High Speed Packet Access (HSPA), Universal Mobile Telecommunications System (UMTS), GSM**

up to 5 gigabits per second to users within an indoor environment, usually within a range of 10 metres. It satisfies the standards of IEEE 802.15.3C

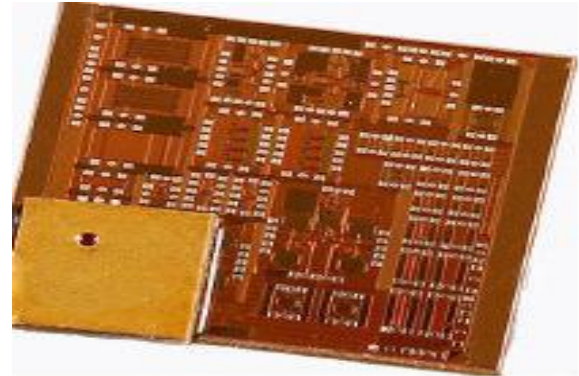

**Figure 5.1: The Gi-Fi integrated wireless transceiver chip developed at the National ICT Research Centre, Australia.**

## V. THE Gi-Fi

Gi-Fi will help to push wireless communications to faster drive. For many years cables ruled the world. Optical fibers played a dominant role for its higher bit rates and faster transmission. But the installation of cables caused a greater difficulty and thus led to wireless access. The foremost of this is Bluetooth which can cover 9-10mts. Wi-Fi followed it having coverage area of 91mts. No doubt, introduction of Wi-Fi wireless networks has proved a revolutionary solution to “last mile” problem. However, the standard’s original limitations for data exchange rate and range, number of channels, high cost of the infrastructure have not yet made it possible for Wi-Fi to become a total threat to cellular networks on the one hand, and hard-wire networks, on the other. But the man’s continuous quest for even better technology despite the substantial advantages of present technologies led to the introduction of new, more up-to-date standards for data exchange rate i.e., Gi-Fi.

Gi-Fi or Gigabit Wireless is the world’s first transceiver integrated on a single chip that operates at 60GHz on the CMOS process. It will allow wireless transfer of audio and video data up to 5 gigabits per second, ten times the current maximum wireless transfer rate, at one-tenth of the cost, usually within a range of 10 meters. It utilizes a 5mm square chip and a 1mm wide antenna burning less than 2 watts of power to transmit data wirelessly over short distances, much like Bluetooth.

### 5.1 More About Gi-Fi:

Gi-Fi is the world’s first transceiver integrated on a single chip that operates at 60GHz on the CMOS process. It will allow wireless transfer of audio and video data at up to 5 gigabits per second, ten times the current maximum wireless transfer rate, at one-tenth the cost. NICTA researchers have chosen to develop this technology in the 57-64GHz unlicensed frequency band as the millimetre-wave range of the spectrum makes possible high component on-chip integration as well as allowing for the integration of very small high gain arrays. The available 7GHz of spectrum results in very high data rates,

### 5.2 Working In Gi-Fi:

Here we will use time division duplex for both transmission and receiving. We will data files are up converted from IF range to RF 60GHz range by using 2 mixers. We will feed this to an power amplifier, which feeds milli meter wave antenna. The incoming RF signal is first down converted to an IF signal centered at 5 GHz. and then to normal data ranges, here we will use heterodyne construction for this process to avoid leakages due to direct conversion. Due to availability of 7GHz spectrum the total data will be transferred within seconds.

### 5.3 Gi-Fi uses 60 GHz

Here we will use milli meter wave antenna which will operate at 60GHz frequency which is unlicensed band. Because of this band we are achieving high data rates energy propagation in the 60 GHz band has unique characteristics that make possible many other benefits such as excellent immunity to co-channel interference, high security, and frequency re-use.

Point-to-point wireless systems operating at 60 GHz have been used for many years for satellite-to-satellite communications. This is because of high oxygen absorption at 60 GHz (10-15 dB/Km). This absorption attenuates

## VI THE Li-Fi

The term **Li-Fi** was coined by pure Li-Fi’s CSO, Professor Harald Haas, and refers to light based communications technology that delivers a high-speed, bidirectional networked, mobile communications in a similar manner as Wi-Fi. Although Li-Fi can be used to off-load data from existing Wi-Fi networks, implementations may be used to

provide capacity for the greater downlink demand such that existing wireless or wired network infrastructure may be used in a complementary fashion. Li-Fi is the use of the visible light portion of the electromagnetic spectrum to transmit information at very high speeds. This is in contrast to established forms of wireless communication such as Wi-Fi which use traditional radio frequency (RF) signals to transmit data.

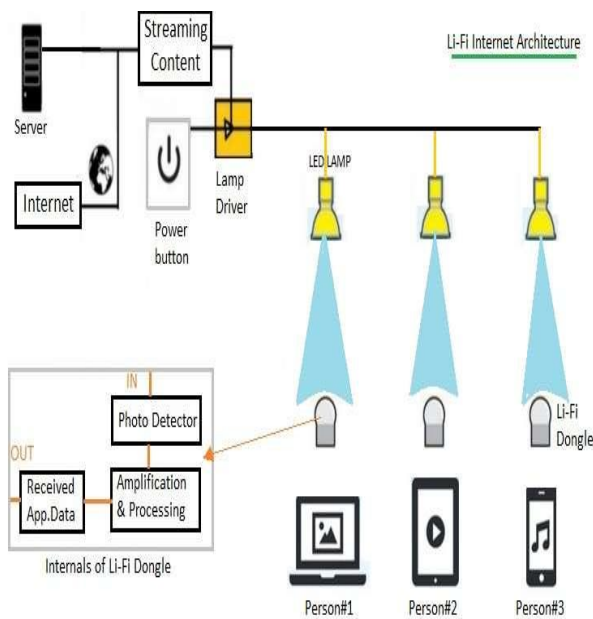

Figure 6.1: Working model Of Li-Fi

a) Comparison of Li-Fi and Wi-Fi

Li-Fi / Wi-Fi comparison

Parameter	Li-Fi	Wi-Fi
Speed	***	***
Range	*	**
Data density	***	*
Security	***	**
Reliability	**	**
Power available	***	*
Transmit/receive power	***	**
Ecological impact	*	**
Device-to-device connectivity	***	***
Obstacle interference	***	*
Bill of materials	***	**
Market maturity	*	***

\* low \*\* medium \*\*\* high

Table 6.1: Comparing Li-Fi and Wi-Fi

b) Limitations of Li-Fi

One problem is that OLEDs emit a fairly broad spectrum of light, and different wavelengths will pass through the grating at different angles, forming a rainbow. To minimize this, the team searched for OLEDs with very narrow emission characteristics. OLEDs constructed with the rare earth element europium offer narrow emission, but they aren't very efficient. Samuel says his team has managed to raise the efficiency—the amount of input energy that comes out as light—to 4.3 percent. Another option is to add quantum, which have narrow emission spectra, as a color conversion layer in the OLED, Samuel says. The underlying OLED would cause the dots to emit the desired color of light.

VII KEY CHARACTERISTICS OF WIRELESS TECHNOLOGY

7.1. Approach

This paper focuses on the hypothesis that which wireless technology, Wi-Fi, WiMAX, Gi-Fi and Li-Fi provides a better solution in the wireless access infrastructure. Whether one wireless technology provides a better solution than any other or whether a combination of technologies is needed to create the desired infrastructure.

7.2. Efficiency

Efficiency of wireless technology is measured in terms of bandwidth and latency. Efficiency is a major issue to determine what type of applications can be run on a network. A less bandwidth network only feasible for small application and normally support simple data application for example transferring text files. A higher bandwidth network normally used for big application such as audio and video and many powerful applications.

7.3. Range

Range is evaluated from the measured distance needed between base stations, the number of devices needed to support the infrastructure, and whether the technology has the ability to switch/hand-off between base stations without loss of coverage. The distance needed as well as the ability to switch/hand-off between base stations was obtained from previous research conducted on each technology and the number of base stations required is an estimate based on allowable distance between them.



## . COMPARATIVE STUDY

This chapter presents a comparison of existing and emerging wireless technologies: Wi-Fi, WiMAX, Gi-Fi and Li-Fi. This part concludes and presents a conclusion of which will be the best technology to build a wireless access infrastructure. The overall comparisons of the above technologies are given under.

### 8.1. Radio Technology:

Wireless technologies differ in the radio technology sector. The IEEE 802.11 WLAN standards describe four radio link interfaces that operate mainly in unlicensed radio band having range from 2.4 GHz to 5 GHz. The WiMAX 802.16a standard released in January 2003 operates between 2 GHz and 11 GHz.

Within IEEE 802.16a's 2-11 GHz range, four bands are as follows:

- Licensed 2.5 GHz MMDS
- Licensed 3.5 GHz Band
- Unlicensed 3.5 GHz Band
- Unlicensed 5 GHz Band

Characteristics	802.11(Wi-Fi)	802.16(WiMAX)	802.15(Gi-Fi)	802.15.7(Li-Fi)
Frequency Band	2.4 to 5 GHz	2 to 11 GHz	57-64 GHz	100 times of Tera HZ

Table 8.1 Comparison of Frequency Bands Of Wireless Technologies

### 8.2. Radio Transmission Modulation Techniques:

**802.11b (<=11 Mbps)** – The 802.11b radio link uses a direct sequence spread spectrum technique called **complementary coded keying (CCK)**. The bit stream is processed with a special coding and then modulated using Quadrature Phase Shift Keying (QPSK).

**802.11a and g (<=54 Mbps)** – The 802.11a and g systems use 64-channel orthogonal frequency division multiplexing (OFDM). In an OFDM modulation system, the available radio band is divided into a number of sub-channels and some of the bits are sent on each. The transmitter encodes the bit streams on the 64 subcarriers using Binary Phase Shift Keying (BPSK), Quadrature Phase Shift Keying (QPSK), or one of two levels of Quadrature Amplitude Modulation (16, or 64-QAM). Some of the transmitted information is redundant, so the receiver does not have to receive all of the sub-carriers to reconstruct the information.

### 8.3. Efficiency:

Efficiency of wireless technology is measured in terms of bandwidth and latency. Bandwidth describes the maximum data transfer rate of a network or Internet connection. It measures how much data can be sent over a specific connection in a given amount of time.

Characteristics	Wi-Fi	WiMAX	Gi-Fi	Li-Fi
Bandwidth	20 MHz	20 MHz	5 gps	1 to 1.3 gps
Latency	50ms	25 to 40ms	N/A	N/A

Table 8.3 Comparison of Bandwidth and latency of Wireless Technology

### 8.4. Security:

One of the major issues that differentiate the wireless technologies is security. It is a major issue because it protects transmissions from eavesdropping. But security has been one of the major lacking in Wi-Fi, here encryption is optional. But for Wi-Fi better encryption techniques are now available.

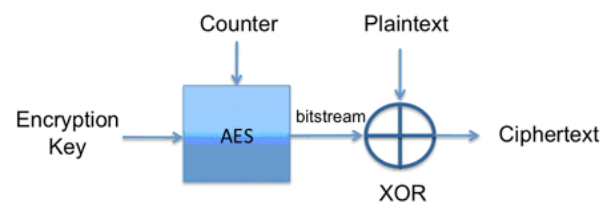

By 2020, the market share of the photo detector segment is expected to grow very rapidly :

At present, only one-way communication is possible with the help of VLC, which requires the installation of LED and installation of some applications on phones and tablets, and a cloud server to maintain the storage platform. However, with the advent of two-way communication by the end of 2020, the market share of the photo detector segment, which includes photodiodes and image sensors, is expected to grow very rapidly. The upcoming changes and advancements in the wireless standards will only offer better internet experience to the consumers. Compared to the mature markets such as North America, the Asia-Pacific and Latin American regions are expected to grow at quite high rates in the next 5 years with Compound Annual Growth Rates (CAGRs) of 22.6% and 20.2%, respectively. The growth rate of the Wi-Fi market in Asia-Pacific is propelled by factors such as high development in wireless and smart devices, increase in construction of smart highways and cities, increasing government participation and support, among others.

Features	802.11(Wi-Fi)	802.16(WiMAX)	802.15(Gi-Fi)	802.15.7(Li-Fi)
Primary Application	Wireless LAN	Wireless MAN	Wireless PAN	Wireless PAN
Range and coverage	20-100 meters	50 kilo meters	10 metres	10 metres
Cost	High	High	Low	Low
Frequency Band	Unlicensed Band 2.4 GHz to 5 GHz	Licensed and Unlicensed Band 2 GHz to 11 GHz	Unlicensed Band 57 GHz to 64 Ghz	Visible Light Spectrum More than 100 times Tera Hz
Channel Bandwidth	On the range from 20-25 MHz	Adjustable range From 1.25 to 20 MHz	5 Gbps	1 to 3.5 Gbps
Latency	50 ms	25 to 40 ms	N/A	N/A
Radio Technique	OFDM 64 channels And Direct Sequence Spread Spectrum	OFDM 256 Channels	FCC 47 CFR 15.255 Ultra Wideband (UWB)	optical orthogonal frequency-division multiplexing (O-OFDM)
Security	Security is better. Encryption technique like WPA and WEP available	Good Security. AES	High	Very High
Mobility	In the development Phase now	Mobile WiMAX Build in to 802.16e	Low	Low

**Table 8.7 Overall comparison of Wireless Technologies**

### CONCLUSIONS

This paper has studied four wireless standard technologies. Wi-Fi(802.11), WiMAX(802.16), Gi-Fi(802.15) and Li-Fi(802.15.7) in terms of how they could be applied to the creation of a wireless access infrastructure. Technical data was collected for these technologies and these technologies were compared using some key characteristics. The wireless communication already contributed a huge revolution in the telecom sectors from the last three decades. Wi-Fi gives us the point-to-multiple point internet facility, by which we can create the Wi-Fi hotspot zone anywhere. Wi-Max completely revaluated the business world for the faster internet facility. Now according to the demand of consumers we introduced the Li-Fi technology for more than 1 Gbps speed. Gi-Fi follows the tradition of Li-Fi. More and more research should be done in the field of these new wireless technology and its applications. The Bluetooth, which covers 9-10mts range and Wi-Fi followed 91mts, so we have no doubt introduction of Wi-Fi wireless network. It has been proved a revolutionary solution to Bluetooth problem-the standard original limitations for data exchange rate and range, number of chances, high cost of infrastructure etc. It have not yet possible for Wi-Fi to become a power network, then towards this problem the better technology despite the advantages of rate present technologies led to the introduction of new ,more up to date for data exchange that is GI-FI.

The comparison is performed between Gi-Fi and existing wireless technologies in this paper shows that these features along with some other benefits that make it suitable to replace the existing wireless technologies. It removes cables that for many years ruled over the world and provides high speed data transfer rate. Gi-Fi technology has much number of applications and can be used in many places and devices such as smart phones, wireless pan networks, media access control. But when we follow the availability of facilities, price, operating system by the users, complexity- the Gigabyte Technology is not

suitable for the common users. The Li-Fi system is also follows the path of Gi-Fi. That's why till this date the Wi-Fi is more popular than any other technologies available there.

### REFERENCES

1. Richard k. gilbert, "Past, present, and future of Wireless Communication Technology", INFSCI, November 12, 2003.
2. Andrea goldsmith," Wireless communications", Cambridge university press, Aug 8, 2005.
3. Institute of Electrical and Electronics Engineers. IEEE Std 802.11-2007, "Wireless LAN Medium Access Control (MAC) and Physical Layer (PHY) Specifications", 12 June 2007.
4. Harald Haas, "Wireless data from every light bulb", TED global, Edinburgh, July 2011.
5. An IEEE standard for Visible Light Communication Communication visiblelightcomm, dated April 2011, D. Tsonev, S. Sinanovic, Hass Harald, 15 Septumber, 2013.
6. Dhakane V.N, Ravi R.N, " Light-Fidelity: A Reconnaissance of Future Technology", International journal of advanced research in computer science and software engineering, VOL 3, Issue 11, November 2013.
7. Praveen B., Punil N. and Sravanthi M., " Li-Fi (Light-Fidelity): The Next Generation of Wireless Network", International journal of in advanced trends in computer science and engineering, VOL.3, P: 132-137, 2014.
8. Dobroslav T., Stefan V., Haral H.," Light Fidelity (Li-Fi): Towards-All Optical Networking", Institute for Digital Communications, Li-Fi and R&D Center, Edinburgh, UK, 2014.
9. N. Navyatha, T.M.Prathyusha, V.Roja, M. Mounika, " Li-Fi (Light Fidelity )- LED Based Alternative", International journal of scientific and Engineering Research, VOL.4, Issue .5, May, 2013.