

# Design and static analysis of a Go-Kart Chassis by ANSYS simulation

Prof. Gaurav R. Mohite<sup>1</sup>

Pramod T. Korde<sup>2</sup>, Pramod P. Derkar<sup>3</sup>, Nikhil M. Nimkar<sup>4</sup>, Nitish V. Tiwari<sup>5</sup>

Assistant professor, department of mechanical engineering

UG students, Priyadarshini Bhagwati College of Engineering, Harpur Nagar,

Umred Road, Nagpur-440024, Maharashtra INDIA

**Abstract** - A Go Cart also spelled as Go Kart is a four wheeled vehicle designed and meant for racing only (though in some countries it is used for fun personal transportation). It is a small four wheeler run by I.C Engine. It is a miniature of a racing car.

This paper aims to the design, analysis of a go kart chassis. The main intention is to do design and static analysis of go-kart chassis. The maximum deflection is obtained by analysis. The go-kart chassis are different from the chassis of ordinary cars on the road. The paper highlights the material used and structural formation of chassis. The strength of material, rigidity of structure and energy absorption characteristics of chassis is discussed. The modelling and analysis are performed using 3-D software such as CREO and ANSYS. The loads are applied to determine the deflection of chassis.

**Keywords:** Chassis Design, ANSYS, impact forces, analysis

## 1. Introduction-

The Go-kart is a vehicle which is compact, simple, lightweight and easy to operate. The go-kart is designed for flat track racing so, its ground clearance is very small as compare to other vehicle hence it skips the suspension. The parts of go-kart are engine, steering, axle, tyres and bumpers. The engine used for go-kart is either two strokes or four stroke engine. The electric motors are also used instead of engine, known as "eco-kart". The go-karting is a variant open wheel motor sport with small, open, four wheeled vehicles. The chassis is independent of suspension to experience thrill.

Go-karting is a great outlet for those interested in racing because of its simplicity, cost and safer way to race. The track can be indoor or outdoor. The go-kart racing tracks are simple than the F1 racing tracks. Practicing on go-karting can properly expose the driver to the actual racing environment training them to be professional motor racer in various competitions such as formula 1, NASCAR.

## Objectives-

The objectives of paper are as follows:

- 1) The selection of material for chassis.
- 2) To construct the appropriate chassis for go-kart.
- 3) To determine the maximum stress concentration areas.

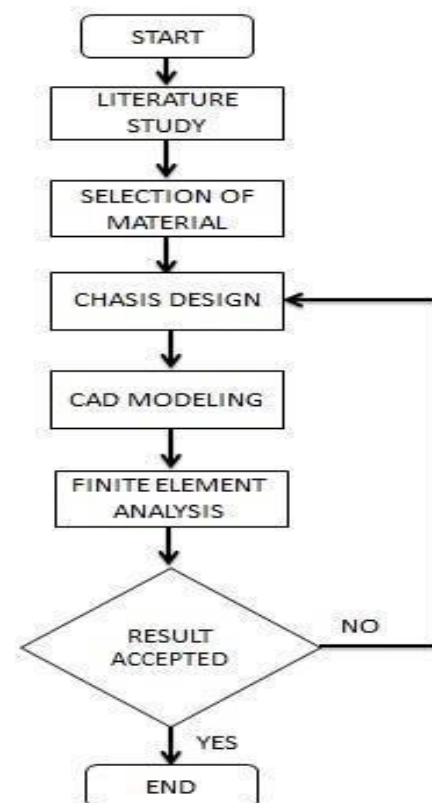

FIG.1 FLOW CHART : PROCESS METHODOLOGY

## 2. Chassis-

The chassis of go-kart is a skeleton frame made up of pipes and other materials of various cross sections. The chassis of go-kart must consist of stability, torsion rigidity, as well as it should have relatively high degree of flexibility as there is no suspension. It can also adequate strength to sustain load of operator and other accessories. The chassis is design by convenience and safety for operator.

The chassis was designed for a safe ride and the load is applied on it without compromising the structural strength. Be aware that you want a strong but light frame. We suggest 3.125mm thick tubing, either square or round (or both) depending on preference. The bending operation of the material used should be easier. By adding filler material to the notched area during welding operation strength of frame can be increase.

## 3. Material and methodology-

The amount of carbon in steel is important to determine the strength, hardness, and machining characteristics. Material selection of the frame plays an important role in providing desired strength, endurance, safety and reliability of the vehicle. The material used for chassis are various grades of steel or aluminum alloys. The main component of steel is carbon which increases the hardness of material of chassis. Aluminum alloy is expensive than steel so mainly steel is used to constructs the chassis

Properties	AISI4130	AISI1020	Al6063
Density	7.55	7.85	2.8
U.T.S.	575-760 Mpa	320-340 Mpa	200 Mpa
Yeild strengt	460	280	240
Young's modulu	190-210 Gpa	190-250 Gpa	70 Gpa
Weldin g method	M.I.G.	Any method	Any method

## 4. Bumper-

The bumper provides the safety by absorbing maximum impact force and protects the chassis.

## 5. Design-

The chassis is designed considering the factors like factor of safety - maximum load carrying capacity, force absorption capacity, required space for accessories and driver and specific dimensions.

The design of chassis is performed by using software such as AutoCAD, Solidworks and CREO. The load distribution in the chassis should be uniform. The structural design gives the idea about the chassis. Design gives the optimum size and shape of the chassis.

## 6. Modeling-

The 3-D modeling of chassis is created by CREO:

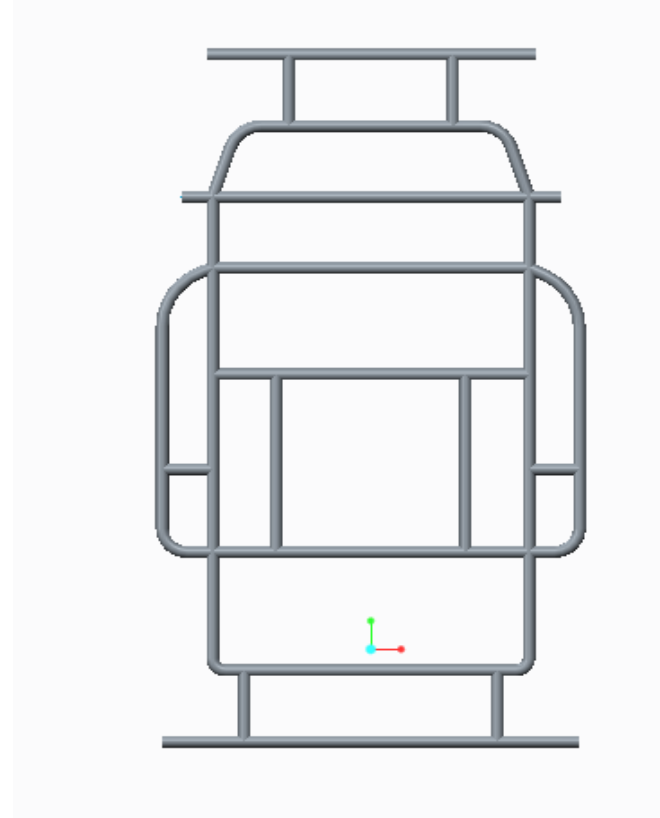

Fig -2: Chassis Model

## 7. Analysis-

The next stage after design is analysis of chassis under various impact forces. The chassis experience loads under condition such as cornering force, torsional rigidity and overall dynamic loads applied during race. By performing analysis, the stresses induced in the structure can be determined.

### 7.1 Finite element Analysis:

The structural analysis is done to know the effect of impact force on the chassis. The impact force testing is performed for worse conditions to determine the maximum deformation. For protection of driver, the frame of driver cabin should resist the impact forces. The driver safety can be checked and improved by analysis.

### 7.2 Meshing:

Meshing is probably the most important part in any of the computer simulations, because it can show drastic changes in results.

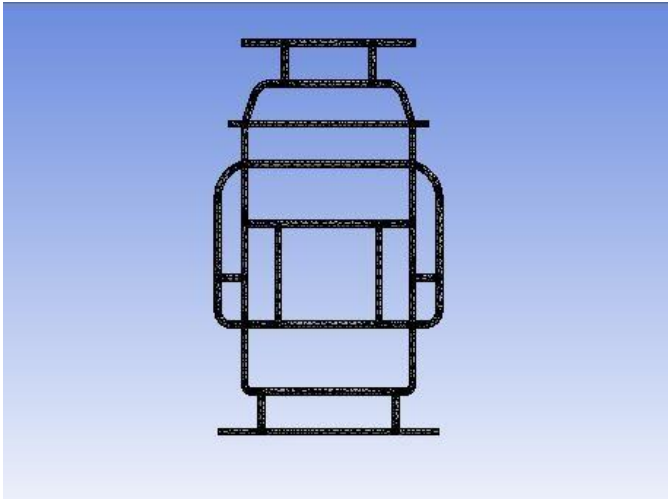

Fig -3: Meshing

### 7.3 Boundary Conditions:

Boundary value analysis testing technique is used to identify errors at boundaries rather than finding those exist in centre of input domain. Boundary value analysis is next part of equivalence partitioning for designing test cases are selected at the edges of the equivalences classes.

**Front impact:** The load of driver and engine is uniformly distributed on the frame.

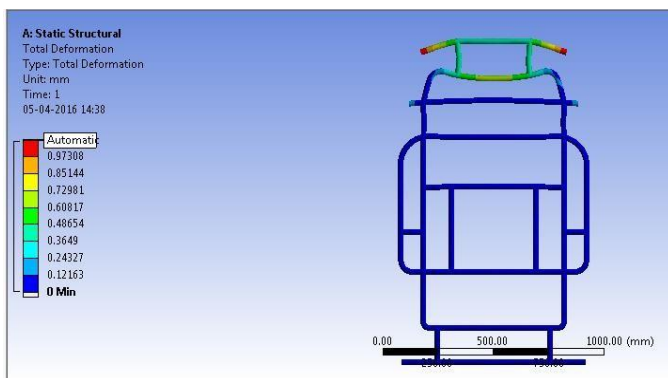

Fig -4: Front impact

### 7.4 Side impact:

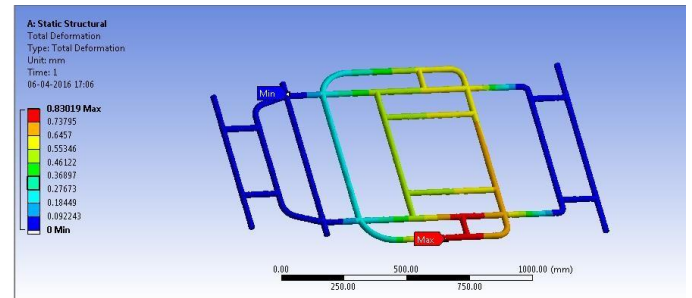

Fig -5: Side impact

### Conclusion

The designing of chassis for go-kart can develop many skills. The learning of 3-D modeling software like Solidworks are essential to obtain desire design. The analysis of design determines the stresses developed in the chassis which plays an important role in factor safety. From the analysis we can predict the chassis is safe or not and also by seeing the deformation and stresses modification in the kart chassis is possible.

### Reference:

- 1) "Design And Analysis Of Hybrid Go-Kart", Prof. Alpesh V. Mehta\*, bMr. Nikunj Padhiar, cMr.Jaydip Mendapara.
- 2) Sane, S.S., Jadhav, G., Anandraj, H., 1995, "Stress Analysis of Light Commercial Vehicle Chassis by FEM
- 3) "Static Analysis of Go-Kart Chassis by Analytical and Solid Works Simulation", Rahul Thavai1, Quazi Shahezad2, Mirza Shahrukh3, Mukri Arman4, Khan Imran5.
- 4) "Design And Analysis Of An Electric Kart", Sathish kumar N1, Vignesh A2.
- 5) "Design And Analysis Of Hybrid Go-Kart", a Prof. Alpesh V. Mehta\*, Mr.Nikunj Padhiar, cMr.Jaydip Mendapara.
- 6) N.K.Ingole, D.V. Bhope "Stress analysis of tractor trailer chassis for self weight reduction" International Journal of Engineering Science and Technology (IJSET), ISSN:0975-5462 Vol. 3 No. 9September 2011