

Encryption Method for Panoramic Ultrasound Doppler Images

Yasameen Al-youzbaki

¹ Eng., Dept. of Applied Electronics and Information Technology, University POLITEHNICA of Bucharest, Romania

Abstract - Ultrasound Doppler panoramic images are characterized as very big size medical images that make their encoding and decoding process at a telemedicine system which it is necessary for their safety storing and transmitting take a long time. In addition to the big complexity of this encryption process because of the large amount of the image processed information. In this paper we introduce a method for encoding and decoding the panoramic ultrasound Doppler images which capable for storing and transmitting them safely, easily and quickly. Time of encoding and decoding will be computed for different ultrasound Doppler panoramic images which taken from different Doppler devices.

Key Words: Ultrasound, Panoramic image, Doppler scanning, encoding, decoding, telemedicine.

1. INTRODUCTION

electronic data and communications technologies is now provide and hold up health care and medicine study even for a far distances between the users, this technique is called Telemedicine. Through this process there is an available of transmission for high-resolution X-rays, cardiology, orthopedics, dermatology and psychiatry. Frequently, interactive video and audio are used for patient treatments and help on procedures.[1,2]

Doppler ultrasound scanning (DUS) is used now to detect and measure the flow of blood and verify the existence of arteries' defects.]. For the purpose of analytic the affected areas from the artery, a complete view should be provided from the accurate sequential images. The physician can examine only small different parts of the whole operating field at once, due to the limited field of view for the Doppler's prop, Doppler ultrasound exam results are many videos or images mainly for the long artery. Thus the determination of affected areas for the whole artery is difficult and inaccurate [3,4].

Panoramic images are now used for an accurate diagnosis due to their clear details, wide field of view. Recently panoramic images are used in X-ray for long boons and in fluorescence endoscopy for internal scanning of bladder. Also, a panoramic image for the artery gotten by a Doppler exam is a new project introduced in our previous work in [5].

In this paper our scheme encodes Doppler panoramic images from different Doppler devices with code stream in a new way to less time of encoding and decoding process for those medical image. Comparing with the time needed by other methods, medical images with our method are taking less time for encryption and decryption. Also, these images have exact details must be protected using an encryption method which keep their details and recovery them full and accurate after decryption. After encoding process, the image saved as a file not as an image for leasing the storage space for this big size image.

2. CREATING PANORAMIC IMAGES

Fig.1and Fig.2 are showing the resulting images from Different types of Doppler devices for the artery and vein in the thigh.

Stitching images is based on an image registration process and local transformations, then using the total transformation to place the images in a l common coordinate which is the coordinate system of the first image. Pre-processing was not used, so images used were very noisy. The producing panoramic image gives an overview of the whole region of interest and stitching images from different sequential regions with overlapping areas as shown in figures (1, 2 and 3).

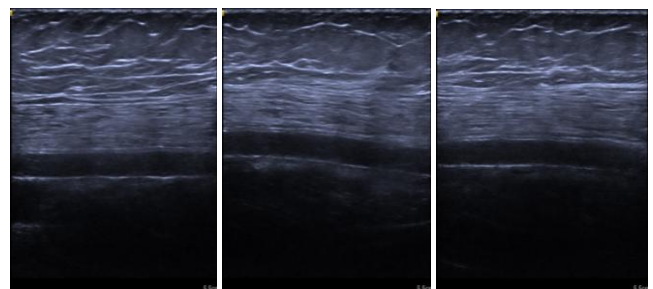

Fig-1: Vein images in the thigh from Doppler.

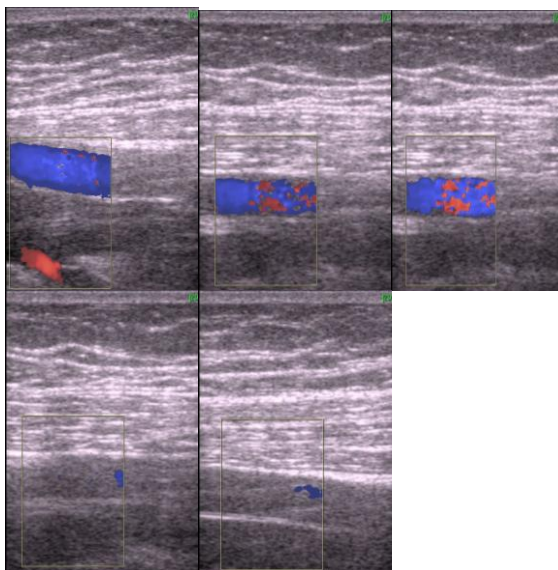

Fig- 2: Artery images in the thigh from Doppler

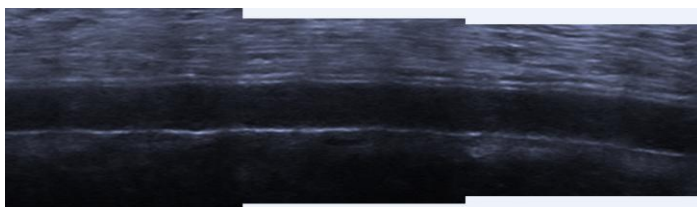

Fig- 3: A panoramic image for the artery in the Thigh with Doppler images in Fig. 1 Doppler device (SIEMENS, 18L6 HD, PV-ART, 2D, H12.00MHz

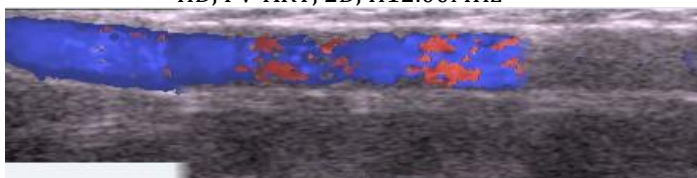

Fig-4: A panoramic image for the vein in the Thigh with Doppler images in Fig 2, device MEDISON, 2D, 92db, 1.5 KHz

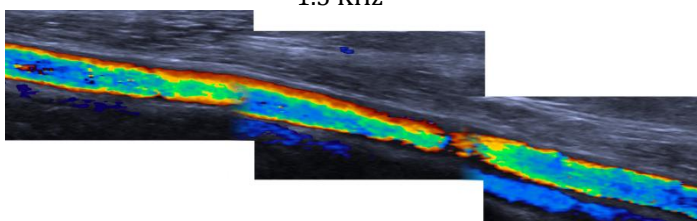

Fig- 5: A panoramic image for three Doppler videos acquired by Doppler device Siemens 18L6 HD, 2D, 12MHZ.

2.1 Similarity Measure

This measurement has been commonly and productively used in biomedical images. In most sequences, the registration algorithm is depending on the direct operation of gray levels of images. Similarity measure S is then computed from gray levels of images, as shown in Eq. (1).[5, 6]

$$SSD = \sum_{x \in I_i \cap I_{i+1}} [I_{i+1}(x) \circ T_{i,i+1}(M) - I_i(x)]^2 = \sum_{x \in I_i \cap I_{i+1}} [I_{i+1}(T_{i,i+1}(x;M)) - I_i(x)]^2 \quad (1)$$

Where (SSD) is the sum of the squared differences of gray levels of images for each pixel of coordinates (x) that is common to both images I_i and I_{i+1} . [6, 7] The above transformation parameters are found in the image transformation matrix. The overlap area is changed according to the size, type and clearness of the Doppler images. In the panoramic images in Fig. 3, 4 and 5, the overlapping area is 10% from the whole size of the original stitched images. [5, 8]

3. ENCODING AND DECODING PROCESS FOR MEDICAL IMAGES.

A lot of works have been used to improve the security of the medical images during the last decades. The color information in those images is very useful for practical purposes; also color information is necessary with gray scale images applications. Different researchers have proposed several image encoding algorithms to enhance the security of medical images [9, 10]. In this paper, we introduce a method of encoding / decoding medical images process which depends on the image color information. This method is characterized by speed and accuracy in the process of encryption and decryption. Speed is needed because we may store a large number of medical images which processed from different ultrasound devices in a telemedicine system and these images have a large size compared with the size of the usual images. Also, the browser over the Internet or internal network user in hospital or other medical images supply, still need to present the identification decoded image after a full load. [11, 12] Speed of decoding the images and the accurate of its details after decoding is an advantage of our method specially for the big size panoramic images.[13, 14] Fig. 6 shows the suggested encoding scheme, where the key is taken from the original image and this makes our key is not constant, it is changed with the image change and that gives more security for those images. The key is stored in a known coordinates within the image to be used later in the decryption process.

Time of decoding the images in our method is few (2-5 seconds depends on image size) compared with other used methods like wavelet encoding method and Huffman method. Also, this method keeps details of images with high accuracy after decoding.[15, 16]

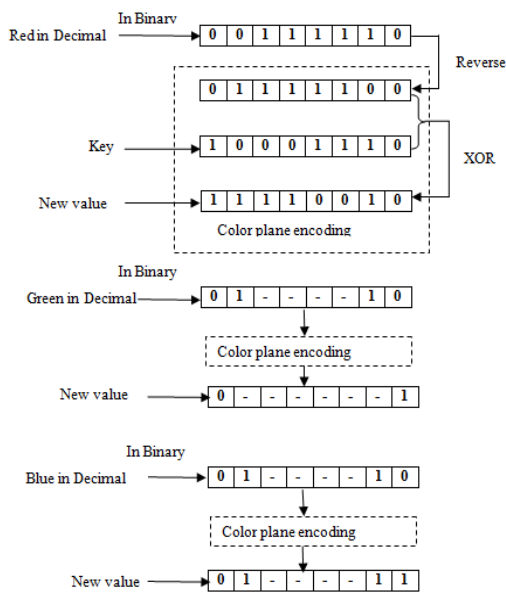
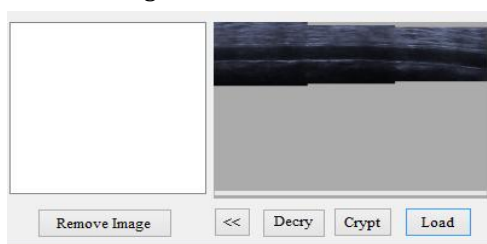
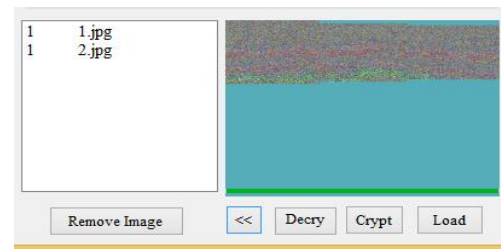

Fig-6: Encoding scheme depending on the pixel colors

In Fig.6, presents the process of encoding the panoramic image by using its colors red, blue and green which are encoded by the same key code. This code is taken from the original panoramic image. The first step in this process is about converting the key bits from decimal to binary. The second step works on image color values which also will be converted from decimal to binary and reversed, that will produce a new value. The third step is encoding by the key bits using XOR for all the three image colors in the same way. The key above is used to encrypt the image details, to be stored with its metadata. Storing the encoded Doppler panoramic image needs a big storing space. The proposed method in this paper will encrypt also the head of the file which contain the image with its metadata like some information about this image. This process is hiding the image and its information and save the file in a small stored space. In cases of un- colored Doppler images, the acquired images are only gray scale images. Those types of images should have a processing on their pixels, then we can get a color values. [17, 18, 19], then it's saved in database as a colored image. Devices have color values in its pixels and these values can be notes by our program, thus we can use them in our encryption method.[20] The results encoded panoramic images after using the suggested encryption method are shown in Fig.7, 8 and 9



(a)



(b)

Fig-7: Encoded panoramic image in Fig.3, (a) loading the panoramic image in the designed view.. (b) crypt the loaded image using the suggested encoding method and save this image with its metadata as a file name(1) with two saved images

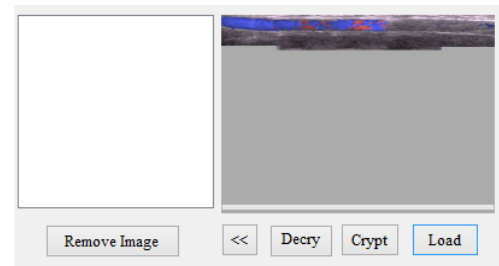

(a)

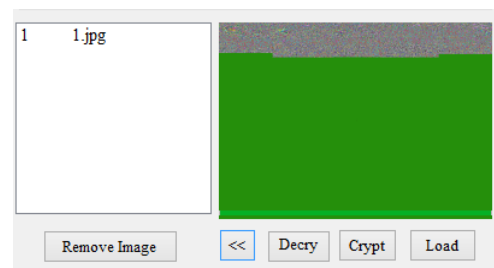

(b)

Fig- 8: Encoded panoramic image in Fig.4, (a) loading the panoramic image in the designed view, (b) crypt the loaded image using the suggested encoding method and save this image with its metadata as a file name(1) with one saved image

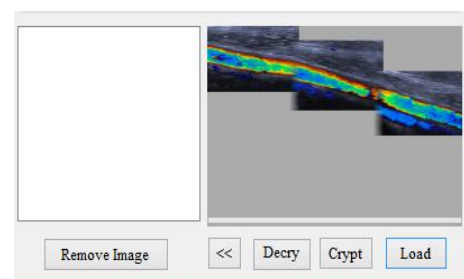

(a)

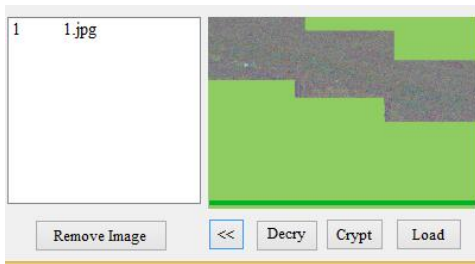

(b)

Fig- 9: Encoded panoramic image in Fig.5 , (a) loading the panoramic image in the designed view, (b) crypt the loaded image using the suggested encoding method and save this image with its metadata as a file name(1) with one saved image

3. RESULTS AND CONCLUSION

In this paper we introduce a new method for encoding and decoding the ultrasound panoramic images which its usefully used in telemedicine systems. Its gives security in saving and transmitting and reduce the storing space of saving and exchanging with users.

As shown in Figures 7, 8, 9 for the results encoded ultrasound panoramic images from different types of Doppler devices; the encryption method by using image colors values was successfully used. Panoramic images details are fully hiding and they saved on the left part from our designed view with their metadata (patient code, disease name, part of body etc.) as a file name only not as an image. This process of saving the panoramic images for ultrasound scanning gives a very big space for saving thousands of those huge images safely.

The other advantages in this suggested encoding method is found at the results decoded panoramic images. This method will keep all the details of this medical image without any distortions in the decoded result panoramic images which are very important for the physicians to give an accurate diagnosis and also for any other image processing methods. Decryption process also done by using the same designed view only by clicking on decrypt icon on the interface as shown in Fig.10

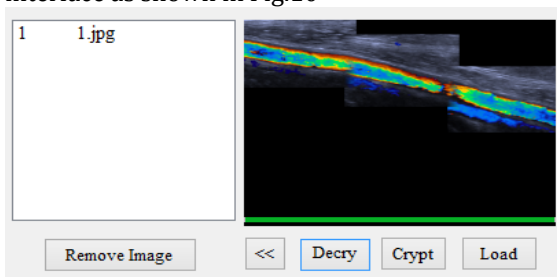

Fig-10: Decrypt panoramic image in the designed view

The metadata can be taken from the saved file (1) and the result panoramic image can be displayed in full size as shown in Fig.11.

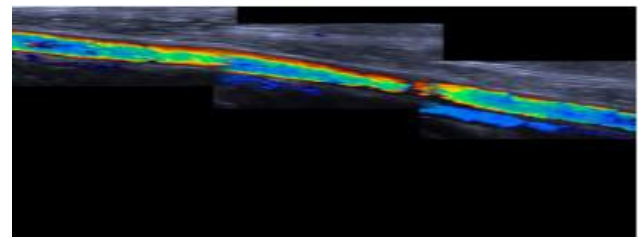

Fig-11: displaying full size panoramic image

The encryption time for the suggested method is related to the panoramic image size as shown in table 1 for some experimental panoramic images.

Table- 1: List of tested panoramic image sizes with their computed encoding time

Image size (MB)	Time of encoding (s)
3.17	2.45
3.78	3.11
4.32	4.29
4.76	4.89
5.61	4.92
6.43	4.95

The computed decoding time for the same images size is mostly spends the same period of time.

REFERENCES

- [1] W.S. Jones, K.M. Schmit, S. Vemulapalli, "Treatment Strategies for Patients With Peripheral Artery Disease", *AHRQ Publication*, no. 13-EHC089-EF, March 2013.
- [2] Z. Chen, Y. Zhao, S.M. Srinivas, "Optical Doppler Tomography", *IEEE Journal of Selected Topics in Quantum Electronics*, vol. 5, 1999, no. 4,
- [3] C. Kargel, G. Plevnik, B. Trummer, "Doppler Ultrasound Systems Designed for Tumor Blood Flow Imaging", *IEEE Transactions on Instrumentation and Measurement*, vol. 53, 2004, no. 2
- [4] Y. Hernández-Mier, W.C.P.M. Blondel, C. Daul, "Fast construction of panoramic images for cystoscopic exploration", *Computerized Medical Imaging and Graphics*, vol. 34, 2010, pp. 579-592
- [5] Yasameen Al youzbaki, S. Stanciu , " Creating panoramic image for linear transducer ultrasound Doppler images", in *E-Health and Bioengineering Conference*, IEEE.explore, 2015, arnumber=7391567
- [6] L. Zhao, H. Feng, J. Bai, "An improved image restoration method for the high definition panoramic camera system", *Optics and Lasers in Engineering*, vol. 47, 2009, pp. 982-989,

- [7] X. Maa, D. Liu, J. Zhang, J. Xin, "A fast affine-invariant features for image stitching under large viewpoint changes", *Neurocomputing*, Vol.151, 2015, pp. 1430-1438
- [8] S.I. Choi, Y.O. Park, H.S. Cho, J.E. Oha, H.M. Cho, "Development of a digital panoramic X-ray imaging system of adaptive image layers for dental applications", *Nuclear Instruments and Methods in Physics Research*, vol. A 652, 2011, pp. 767-770
- [9] M. Kaur, V. Wasson, "ROI Based Medical Image Compression for Telemedicine Application", in 4th International Conference on Eco-friendly Computing and Communication Systems, ICECCS, *Procedia Computer Science*, vol. 70, 2015, pp. 579-585.
- [10] H. Shen, D. Ma, Y. Zhao, "MIAPS: A web-based system for remotely accessing and presenting medical images", in computer methods and programs in biomedicine, vol. 113, 2014, pp. 266-283.
- [11] M. Kumar, S. Agrawal, "Color image encoding in DOST domain using DWT and SVD", in *Optics & Laser Technology*, vol. 75, 2015, pp. 138-145.
- [12] E. X. Bator, J. M. Gleason, A. J. Lorenzo, "The burden of attending a pediatric surgical clinic and family preferences toward telemedicine", in *Journal of Pediatric Surgery*, vol. 50, 2015, pp. 1776-1782.
- [13] D. Dragan, D. Iveti'c, "Request redirection paradigm in medical image archive implementation", in *Computer Methods and Programs in Biomedicine*, vol. 107, 2012, pp. 111-121.
- [14] D. Taubman, R. Prandolini, "Architecture philosophy and performance of JPIP: Internet Protocol standard for JPEG2000", in *Int. Symp. Visual Comm. and Image Proc.*, vol. 5150, 2003, pp. 649-663.
- [15] J. B. Brindha, G. Raghuraman, "Region based lossless compression for digital images in telemedicine application", in *International Conference in Communications and Signal Processing (ICCSP)*, 2013, pp. 537-540.
- [16] B. Kamsu-Foguem, and C. Foguem, "Telemedicine and mobile health with integrative medicine in developing countries", in *Health Policy and Technology* 3, vol. 4, 2014, pp. 264-271.
- [17] . Y. Hsu, "Segmentation-based compression: New frontiers of telemedicine in telecommunication", In *Telemetric and Informatics*, Vol. 32, 2015, pp. 475-485.
- [18] Chen, D.Zhao, "Optical image encryption with Hartley transforms", *Opt. Lett.*, vol. 31, 2006, pp. 3438-3440.
- [19] Z. Liu, Y. Zhang, F. W. Liu, and S. L. Meng, "Optical color image hiding scheme based on chaotic mapping and Hartley transform", *Opt. Lasers Eng.*, vol. 51, 2013, pp. 967-972.
- [20] N. Singh, A.Sinha, and "Gyrator transform-based optical image encryption, using chaos", in *Opt. Lasers Eng.*, vol. 47, 2009, pp. 539-546.