

# Power System Stability Improvement by Using a Thyristor Switched Series Capacitor (TSSC)

Ms. Nayana G. Hinge<sup>1</sup>, Prof. Shradha Umathe<sup>2</sup>

<sup>1</sup>Department of Electrical Engineering, G H Raisonni college of Engineering, Nagpur.  
hinge\_nayan.ghrcemtechips@raisonni.net

<sup>2</sup> Department of Electrical Engineering, G H Raisonni college of Engineering, Nagpur.

\*\*\*

**Abstract** - In this paper, a controller for thyristor switched series capacitor (TSSC) is presented. The controller aim to stabilize the power system by damping inter area power oscillations and by refinement of transient stability of the system. TSSC device is executed in single machine infinite bus system(SMIB) and simulated in MATLAB/Simulink environment. The presented simulation results show that the controller improves the power system stability of both with and without fault condition.

**Key Words:** FACTS, Thyristor switched series capacitor (TSSC), Control system, TSSC impedance, PSS.

## 1. INTRODUCTION

This paper describes the basic operation of thyristor switched series capacitor (TSSC) to improve power transfer and stabilize system. The concept of FACTS introduce to a family of power electronics based devices able to boost ac system controllability and stability and to enlarge power transfer capability. The main types of FACTS devices Thyristor control reactor (TCR), Thyristor switched capacitor (TSC), (TSSC) , (GCSC).Flexible ac transmission systems (FACTS) devices have, during the last decades, occur as an option to improve the stability and to reconcile congestions in today's power system, which are often loaded to levels close to their security limits. These devices are based on power electronic, manage by controlling reactive and active power injections in the power system.

## 2. BASIC OPERATION OF TSSC

The thyristor switched series capacitor is a modification of the fixed series capacitor with a thyristor based static switch connected across the capacitor.

A TSSC consists of a capacitor shunted by appropriately rated bypass valve of reverse parallel connected thyristors in series as shown in below fig.1 The operating principle of the TSSC is straight forward i.e the degree of series compensation is controlled in a step like way by increasing

or decreasing the number of series capacitor inserted .It is placed by turning off and bypass by turning on the corresponding thyristor valve.

A thyristor valve commutates naturally, that is, it turns off when current crosses zero. Thus capacitor can be placed into the line by the thyristor valve only at the zero crossings of the line current. Therefor insertion takes place at line current zero, a full half-cycle of the line current will charge the capacitor from zero to maximum and consecutive, opposite polarity half-cycle of the line current will discharge it from maximum to zero. The capacitor placing at line current zero, necessitated by the switching limitation of thyristor valve, result in dc offset voltage which is equivalent to the amplitude of the ac capacitor voltage. In order to reduce the initial surge current in valve and the corresponding circuit transient, the thyristor valve should be turned on for bypassed only when the capacitor voltage is zero. With the prevailing dc offset, this requirement can conviction a delay of up to one full cycle, which would be set the theoretical limit for the attainable response time of the TSSC. It could be applied for power flow control and damping power oscillation where the required speed of response is moderate. TSSC is operated in different modes.

- 1) Voltage Compensating Mode.
- 2) Impedance Compensating Modes.

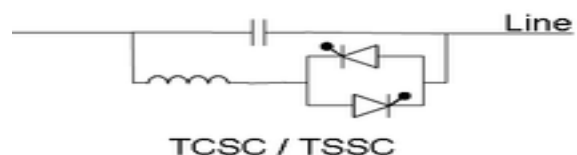

Fig -1: General diagram of TSSC

### 3. SINGLE MACHINE INFINITE BUS SYSTEM

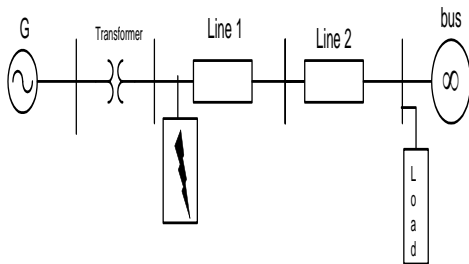

Fig -2: Without series compensation

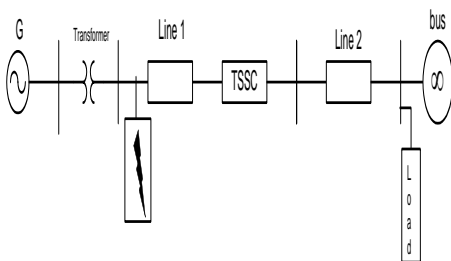

Fig -3: With series compensation

A 1000 MW hydraulic generation plant (machine1) is connected to a load center by a long 500 kV, 700 km transmission line. The load center is modeled by a 1000 MW resistive load . The system has been initialized so that the line sustain 950 MW is close to its surge impedance loading (SIL = 977 MW). SMIB system consist of synchronous machine of 1000 MVA, 3 phase transformer having 1000 MVA ,13.8kv/500kv, Primary winding delta connected and Secondary winding star connected ground with Step up transformer,700km transmission line,3phase resistive load.

In order to enable system stability after faults, the transmission line is series compensated at its center by a TSSC having 21.977e3 ,50Hz, Reactance 0.01H,Average firing delay 4e-3 ( S) , Alpha 78deg, capacitive Operating mode , 50Hz .The machines are equipped with a hydraulic turbine and governor, excitation system and power system stabilizer. These blocks are located in the turbine and regulator subsystems. Two types of stabilizer can be selected first is a generic model using the acceleration power ( $P_a = \text{difference between mechanical power } P_m \text{ and output electrical power } P_{eo}$ ) and a multi-band stabilizer by using the speed deviation ( $dw$ ). The stabilizer type can be selected by specifying a value (0 for No PSS 1 for Pa PSS or 2 for dw MB PSS) in the PSS constant block.

### 4. POWER SYSTEM STABILIZER (PSS)

Power system stabilizer (PSS) is an excitation controller used to damp generator electromechanical oscillations in order to protect the shaft line and stabilize the system and it also detects fluctuations in generator output power and controls the excitation.

#### 4.1 Generic power system stabilizer

The generic power system stabilizer block can be used to damp rotor oscillations of the synchronous machine by controlling its excitation and disturbances occurring in a power system influence electromechanical oscillations of the electrical generators. These oscillations also called power swings, and it must be effectively damped to maintain the system stability. The output signal of the PSS is used as an additional input to the excitation system block. The PSS input signal can be used as either the machine speed deviation ( $dw$ ), or its acceleration power,  $P_a = P_m - P_{eo}$  (difference between the mechanical power and the electrical power).

The generic power system stabilizer is sculptured by the following nonlinear system:

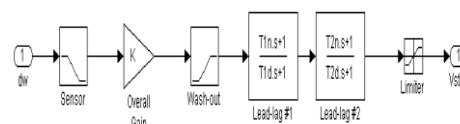

Fig-4: Generic power system stabilizer

To ensure a robust damping, PSS should provide a moderate phase advance at frequencies of regard in order to compensate for the ingrained lag between the field excitation and the electrical torque induced by the PSS action. The above model consists of a low-pass filter, a general gain, a washout high-pass filter, a phase compensation system, and an output limiter. The general gain  $k$  which determines the amount of damping created by the stabilizer. The washout high-pass filter which eliminates low frequencies that are present in the  $dw$  signal and allows the PSS respond only to speed changes. The phase compensation system is represented by a cascade of two first order lead-lag transfer functions and it is used to compensate the phase lag between the excitation voltage and electrical torque of the synchronous machine.

### 4.2 Multi-band power system stabilizer

The disturbances occurring in a power system produce electromechanical oscillations of the electrical generators. These oscillations, also called power swings, and it must be effectively damped to maintain the system's stability. Electro-mechanical oscillations can be classified in four main categories are given below;

1) Local oscillations: It is between a unit and the rest of the generating station and between the latter and the rest of the power system. Their frequencies usually range from 0.8 to 4.0 Hz.

2) Interplant oscillations: It is between two electrically close generation plants. Frequencies can vary from 1 to 2 Hz.

3) Interarea oscillations: It is between two major groups of generation plants. Frequencies are usually in a range of 0.2 to 0.8 Hz.

4) Global oscillation: It is characterized by a common in-phase oscillation of all generators as found on an isolated system. The frequency of such a global mode is usually under 0.2 Hz.

5) The need for effective damping of such a wide range is almost two decades of electromechanical oscillations motivated by the concept of the multiband power system stabilizer (MB-PSS). As its name tell, the MB-PSS structure is based on multiple working bands. Three separate bands are used, respectively dedicated to the low frequency, intermediate frequency, and high frequency modes of oscillations, the low band is usually associated with the power system global mode and the intermediate with the interarea modes, and the high with the local modes. Each of the three bands is made of a differential bandpass filter, a gain, and a limiter (see the figure which are given below called conceptual representation). The outputs of the three bands are summed and passed through a final limiter creating the stabilizer output  $V_{stab}$ . The signal then modulates the set point of the generator voltage regulator so as to boost the damping of the electromechanical oscillations. To fortify robust damping, the MB-PSS should involve a moderate phase advance at all frequencies of recreation to compensate for the inherent lag between field excitation and electrical torque induced by the MB-PSS action.

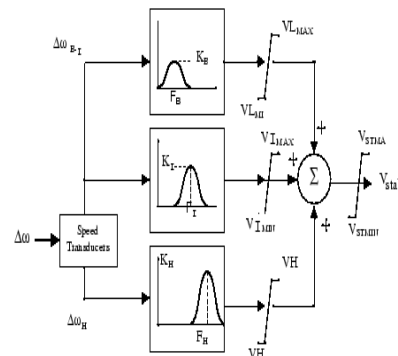
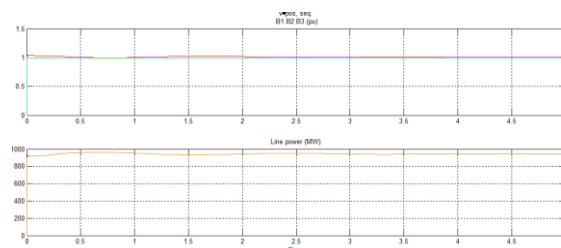

Fig -5: Conceptual Representation

## 5. SIMULATION RESULTS

### 5.1 Condition 1: without series compensation (without fault)

From results we can observed that, the system is stable without any disturbances



Line power: 942MW

Fig-6: System parameter showing voltages across B1 B2 B3(pu) and line power (MW).

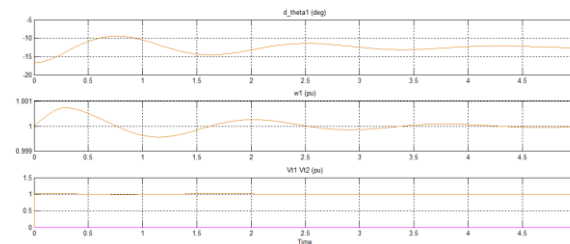
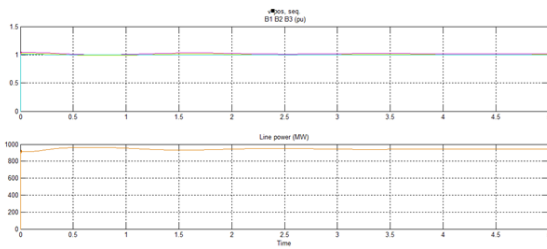

Fig-7 : Machine parameter showing rotor angle, rotor speed, voltage across bus B1.

### 5.2 Condition 2: with series compensation (without fault)



Line power: 950MW

**Fig-8:** System parameter showing voltages across B1 B2 B3 (pu) and line power (MW).

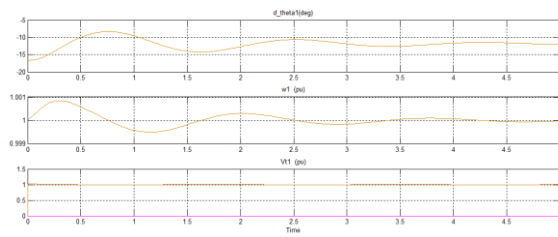

**Fig-9:** Machine parameter showing rotor angle, rotor speed, voltage across bus B1.

**5.3 Condition3 : with series compensation (with LG fault) fault location starting of transmission line 1 for the duration 0.082sec).**

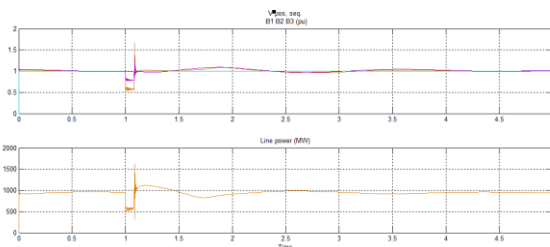

Line power: 952.5MW

**Fig-10:** System parameter showing voltages across B1 B2 B3(pu) and line power(MW).

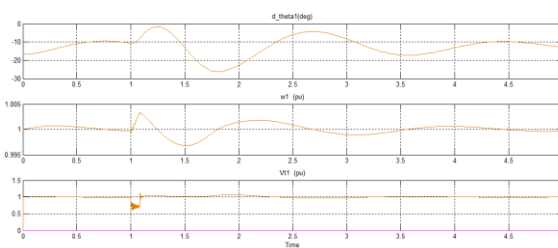

**Fig-11:** Machine parameter showing rotor angle, rotor speed and voltage across bus B1.

**6. CONCLUSIONS**

In this paper, with power system stabilizer i.e system is stable and without PSS the system is unstable. From results we can also concluded that with series compensation to the system, the line power (MW) is improve as compared to without series compensation to the system.

**REFERENCES**

[1] Nicklas Johansson, Lennart Ångquist, and Hans-Peter Nee, "An Adaptive Controller for Power System Stability Improvement and Power Flow Control by Means of a Thyristor Switched Series Capacitor (TSSC)," *IEEE Transactions on power systems*, vol. 25, no. 1, february 2010

[2] Nicklas Johansson, Lennart Ångquist and Hans-Peter Nee, "Preliminary Design of Power Controller Devices Using the Power-Flow Control and the Ideal Phase-Shifter Methods " *IEEE Ttransactions on Power Delivery*, vol. 27, no. 3, july 2012

[3] Nicklas P. Johansson, Lennart Angquist, Hans-Peter Nee, "Adaptive Control of Controlled Series Compensators for Power System Stability Improvement," *IEEE 2007*

[4] Jyoti Govind Agrawal , K.D.Joshi, "Experimental Study of Some Variable Impedance Type FACTS Devices," *2011 Fourth International Conference on Emerging Trends in Engineering & Technology*.

[5] N.G. Hingorani and L Gyugyi, *Understanding FACTS - Concepts and Technology of Flexible AC Transmission Systems*, *IEEE Press, New York, 2000*.

[6] R.M. Mathur and R.K. Varma, *Thyristor-Based FACTS Controller for Electrical Transmission Systems*, *IEEE Press and Wiley Inter science, New York, 2002*.

[7] Brian K. Johnson, "Simulation of TSC and TSSC," *IEEE 2001*.

[8] Farag Ali El-Sheikhi, Yousef Mabruk Saad, Saleh Omar Osman, and Khalil M. El-Arroudi, "Voltage Stability Assessment Using Modal Analysis of Power Systems including Flexible AC Transmission System (FACTS) " *IEEE 2013*.

[9] Eugen Neagu and Rodica Neagu, " New Results Concerning Thermally Stimulated Discharge Current Peak Above Room Temperature" *IEEE 1994*.