

# An Intelligent Vehicular Detection System for Finding Stolen Vehicle

Ms.M.Vinodhini<sup>1</sup>, Ms.S.Sivaranjani<sup>2</sup>, Ms.K.Gugapriya<sup>3</sup>, Mr.P.Manivannan<sup>4</sup>

<sup>1,2,3</sup> Final Year Student, Department of Information Technology, V.R.S. College of Engineering & Technology, Villupuram, Tamilnadu, India.

<sup>4</sup> Assistant Professor, Department of Information Technology, V.R.S. College of Engineering & Technology, Villupuram, Tamilnadu, India.

\*\*\*

**Abstract** - In automobile field, the security and theft prevention are one of the main areas in current scenario. The security goals are achieved by the GSM, GPS technology. But with the increase of number of vehicles, the safety of vehicles becomes more complex and insecure, so there is more demand of safety and security of the vehicle rather than only monitoring its location. Now the more intelligent systems are deployed with increasing popularity, which will also provide some additional benefits to the vehicle users. To fulfill these requirements, the smart system needs to be developed. In this paper, we propose a smart system which will be based on Microcontroller, GPS, GSM and RFID technology, for the monitoring, controlling and security of the vehicle. The place of the vehicle is identified using Global Positioning System (GPS) and Global System for Mobile Communication (GSM). These systems constantly watch the movement of Vehicle and report the status on demand. When the theft is identified, the responsible person send SMS to the microcontroller, then microcontroller issue the control signals to stop the engine motor. To restart the vehicle motor, authorized person need to send the password to controller and open the door. This is more secured, reliable and low cost. This smart system will helps to the vehicle owner or/and operational manager of transport business to operate their vehicles with maximum security and efficiency by gaining the real time insights from the remote vehicle.

**Key Words:** Global Positioning System (GPS), Global System for Mobile Communication (GSM), Microcontroller, RFID.

## 1. INTRODUCTION

In the last few decades, our country has progressed at such a huge rate that many companies have strongly established themselves here. Vehicle Tracking System is now one of the most popular technological changes in all over the world that is going to make our personal and business life lot easier. As the term suggests,

it enables one to track or monitor the location of vehicle in instant time.

Primarily, the system functions with the help of different technologies like the Global Positioning System (GPS), traditional cellular network such as Global System for Mobile Communications (GSM) and other radio frequency medium. But GPS is more effective and accurate in this field. As far as vehicle tracking in India is concerned, its uses and market are expected to increase within a couple of years [1]. Vehicle tracking system in India is mainly used in transport industry that keeps a real-time track of all vehicles in the fleet. The tracking system consists of GPS device that brings together GPS and GSM technology using tracking software. The attached GPS unit in the vehicle sends periodic updates of its location to the route station through the server of the cellular network that can be displayed on a digital map. The location details are later transferred to users via SMS, e-mail or other form of data transfers [3]. The GPS/GSM Based System is one of the most important systems, which integrate both GSM and GPS technologies. It is necessary due to the many of applications of both GSM and GPS systems and the wide usage of them by millions of people throughout the world [2]. This system designed for users in land construction and transport business, provides real-time information such as location, speed and expected arrival time of the user is moving vehicles in a concise and easy-to-read format.

## 2. RELATED WORK

Several security and tracking systems are designed to assist corporations with large number of vehicles and several usage purposes. They can't permit the owner to communicate with the vehicle online, even if the owner is certain that his vehicle was stolen. The proposed security system in this paper is designed to track and monitor vehicles that are used by certain party for particular purposes, also to stop the vehicle if stolen and to track it online for retrieval, this system is an integration of several modern embedded and communication technologies [4]. To provide location and time information anywhere on Earth, the Global Positioning System (GPS) is commonly used as a space-based global navigation

satellite system. The location information provided by GPS systems can be visualized using Google Earth. In wireless data transporting, GSM and SMS technology is a common feature with all mobile network service providers. Utilization of SMS technology has become popular because it is an inexpensive, convenient and accessible way of transferring and receiving data with high reliability. If the car starts running, the client receives a confirmation SMS that it is running now. If this is illegal operation or any intruders try to run the car, the owner can send SMS to switch off the car [5]. Afterwards, the system will check the mobile number for received message, to confirm that the phone number could access the security system.

### 2.1 Anti-Theft Tracking System

The system has two main units [4] [5]. The first is security unit which is embedded in the vehicle. This unit consists of a GSM modem, GPS receiver, control relay, current sensor and Microcontroller. The current sensor will send an analog signal to the microcontroller when the car is running. The microcontroller will send SMS directly to the owner for conformation. NC control relay contacts are connected with the hot line that powers the fuel pump and ECM. The microcontroller can send a signal to the relay to cut off the power, when received SMS contains code from owner mobile to stop it. The GPS Receiver retrieves the location in formation from satellites in the form of latitude and longitude readings in real-time. The Microcontroller processes the GPS information and transmits it to the user using GSM modem by SMS for every 10 minutes.

The Microcontroller also reads engine parameters from vehicle data port and sends them to the second module in the same SMS. The modem receives SMS text that includes GPS coordinates, engine parameters and vehicle engine status. This text is processed using a Visual Basic program to obtain the numeric parameters, which are saved as a Microsoft Office Excel file. To transfer this information to Google Earth, the Excel file is converted to KML (Keyhole Markup Language) format [4]. Google Earth interprets KML file and shows vehicle's location on the map. The system's efficiency is dependable on the sufficiency of the used communication network.

### 2.2 Vehicles Retrieval

When the car is in motion, the client receives a confirmation SMS indicating the status. If this is illegal or any intruder tries to run the car, the owner can send SMS to switch off the car [5]. The system will also check the mobile number of the message sender, to confirm that the phone number is legal or illegal to access the system and if the phone number is legal the system will turn off the car.

### 3. Hardware Design and Implementation

In this smart system we can manage the vehicle from remote place for its continuous monitoring, control and security purpose. We used the RFID technology for detection of unauthorized access of the vehicle, GPS for its location finding and GSM technology for the communication between vehicle and control centre [6]. By using this system, we can find out the efficiency of vehicle as well as driver with adding more safety of vehicles. This is a remotely operated system, without disturbing / informing to any other.

This smart system can be divided in three parts,

- 1) Vehicle Tracking System
- 2) Control Centre
- 3) Communication for Data Transfer

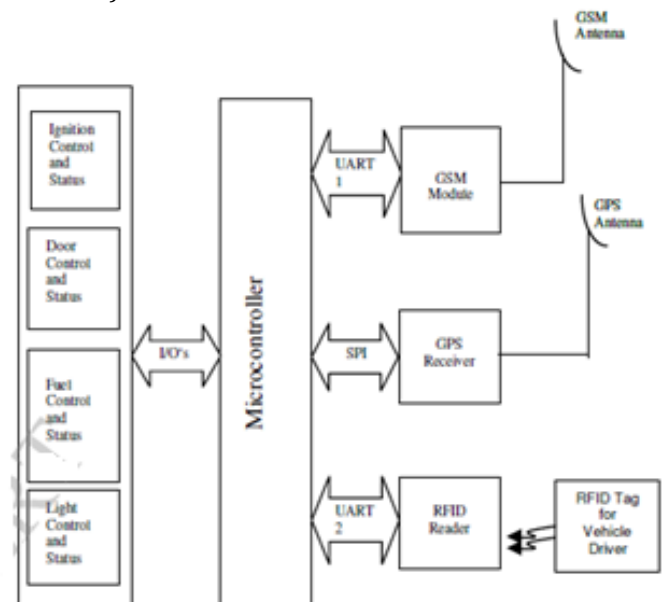

**Figure 1: System Architecture**

#### 3.1 Vehicle Tracking System Unit

In this vehicle tracking system unit, we have used different technologies like,

- GPS technology is used for getting the location, speed and direction of the vehicle [5].
- RFID technology is used to identify the authorized / unauthorized personal access of the vehicle [7] [8].
- GSM technology for communication between vehicle unit and control centre [5].

#### 3.2 Control Centre

Control Centre can have following options for their operations.

- Mobile Station
- Personal Computer Station
- Web Server

### 3.3 Communication for Data Transfer

When all required information is extracted and processed, it needs to be transmitted to a remote control centre which will be able to display this information to the end user. For real time tracking, control and safety of vehicle, reliable data transmission to remote control centre is very important. Wireless network is required to transmit vehicle information to remote control centre. Existing GSM network is selected to transmit vehicle information to remote control centre because of broad coverage of GSM network. It is also cost effective rather than to deploy own network for transmission of vehicle information. For data transmission over GSM network GSM modem is required. GSM modem can send and receive data SMS text messages and GPRS data over GSM network [3].

## 4. RESULTS AND DISCUSSIONS

This GSM based vehicle theft control system retrieves the exact location of a vehicle in terms of its longitude and latitude. This data is fed to the microcontroller, which is interfaced to a GSM modem. The microcontroller retrieves the exact location details from the GPS and sends an SMS to the concerned authority over GSM modem on periodical intervals which is set by the user. An LCD display is connected to the microcontroller for crossing the data received before being sent over GSM. This project will be very useful to people to keep track of their vehicles. Further, this project can be developed by making an arrangement to stop the ignition of the vehicle by the owner remotely by sending an SMS in theft situations.



**Figure 2: GPS and GSM Based Vehicle Theft Intimation**

## 5. APPLICATIONS

These days, growing thefts and malicious activities of vehicles are causing losses of billions across

the world. Therefore, installing GPS in both commercial as well as private vehicles is the need of hour. Currently In-Vehicle unit was implemented with two boards. Microcontroller board was externally connected to GM862-GPS interface board. Single board can be designed to incorporate Microcontroller circuitry on the GM862-GPS interface board. It will reduce the overall size of In-Vehicle unit and it will also reduce the number of components so will the cost [12].

1. After installing a vehicle tracking device in an automobile, a person may easily locate the exact position of that vehicle along with its speed and mileage. Vehicle tracking device also helps the cops in finding stolen vehicles. Certain advanced vehicle tracking devices even deactivate the engine of the vehicle, thus disabling the vehicle from moving.
2. Moreover, parents may always monitor their kids on their journey, thus alerting the driver, that he or she is being watched. Therefore, considering all the safety aspects, a GPS auto tracking device is a necessity in almost every vehicle.
3. Moreover, a GPS vehicle tracking system displays the photograph of the driver driving the vehicle. GPS auto tracking system is very common in the U.S. and is rapidly becoming popular around the world.
4. Moreover, a vehicle tracking device can directly be connected with the personal mobile phone. In case of thefts or any other damages caused to the vehicle, a vehicle GPS tracking device immediately sends an alarm to the mobile for quick action.
5. The best quality of GPS tracking solutions is that, when an individual parks the vehicle in a parking lot and happens to misplace it, then just a phone call to the GPS customer service department will activate an alarm by making the lights flash, thus helping in finding the vehicle.

Therefore, GPS tracking solutions help in locating the vehicle, save fuel by warning the drivers from over speeding and avoiding heading in wrong direction, controlling speed of vehicle, controlling Door open/close, Ignition on/off controlling.

## 6. CONCLUSION

In this paper, we have proposed a novel method of vehicle tracking and locking systems used to track the theft vehicle by using GPS and GSM technology. Based on the above illustrative discussions, it is evident that the proposed Microcontroller, GPS, GSM and RFID based smart system for the remote vehicle monitor, control, security and fuel management purpose, has a Business Intelligence (BI) capabilities. Hence, this smart system for vehicle monitoring, controlling and security will helps to the vehicle owner or operational Manager of transport

business to operate their vehicles with maximum security and efficiency by gaining the real time insights from remote vehicle to make the optimal and timely decisions.

## REFERENCES

- [1] P.Muruganandham, R. Mukesh, "Real Time Web Based Vehicle Tracking Using GPS", World Academy of Science, Engineering and Technology, 61, 2010.
- [2] Chen, H.Chiang, Y. Chang, H. Wang (2010). Toward Real-Time Precise Point Positioning: Differential GPS Based on IGS Ultra Rapid Product, SICE Annual Conference, The Grand Hotel, Taipei, Taiwan August 18-21.
- [3] Tamil, E.M.D.B. Saleh and M.Y. Idris, "A Mobile Vehicle Tracking System with GPS/GSM Technology", Proceeding of the 5th student conference on research and development, May 2007.
- [4] Hu Jian-ming, Li Jie, Li Guang-Hui, "Automobile Anti-theft System Based on GSM GPS Module, "Intelligent Networks and Intelligent Systems (ICINIS)", 2012 Fifth International Conference on , vol. 2, No. 3, pp.199, 201, 1-3 Nov. 2012.
- [5] Montaser N. Ramadan, Mohammad A. Al-Khedher, Sharaf A. Al-Kheder, "Intelligent Anti-Theft and Tracking System for Automobiles", International Journal of Machine Learning and Computing, Vol. 2, No. 1, February 2012.
- [6] Ms. Sadhana Tate, Mr. Mahadev Mote, "Smart System for Vehicle Security and Management", International Journal of Engineering Research & Technology (IJERT), Vol. 1 Issue 9, November - 2012.
- [7] Xigonu Fan, Yulin zhang, "A Design of Bi-verification vehicle access intelligent control system on RFID", IEEE 9<sup>th</sup> international conference on electronics and measurement, 2009.
- [8] Huaquan Gua, J.J. Ang ,F.Tau, "An Automation Security System For Anti Theft", IEEE Eighth international conference on network, 2009.
- [9] Vehicle Tracking Systems Overview [Online:] <http://www.roseindia.net/technology/gps/automatic-vehicle-lo cation.shtml>.
- [10] Elit Wireless Solutions (2007) GM862-GPS Hardware user guide. 1v0300728 Rev. 8 - 20/09/07 World Academy of Science Engineering and Technology 61 2010 99.

[11] RFID-<http://www.rfid-handbook.de/rfid>.

[12] Devyani Bajaj, Neelesh Gupta, "GPS Based Automatic Vehicle Tracking Using RFID", International Journal of Engineering and Innovative Technology (IJEIT) Volume 1, Issue 1, January 2012.

## BIOGRAPHIES



**Mr.P.Manivannan**, received his Bachelor degree in Computer Science and Engineering from Anna University, Chennai in 2009 and his Master degree in Network Engineering from Anna University of Technology, Coimbatore in 2011. At present he is working as Assistant Professor in Department of Information Technology at V.R.S. College of Engineering and Technology, Arasur. His areas of interest are Computer Networks, Cryptography and Network Security, Mobile Communication.



**Ms.M.Vinodhini** is pursuing her Final Year Bachelor Degree in the Department of Information Technology at V.R.S. College of Engineering and Technology, Arasur. Their areas of interest are Cryptography and Network Security and Mobile Communication.



**Ms.S.Sivaranjani** is pursuing her Final Year Bachelor Degree in the Department of Information Technology at V.R.S. College of Engineering and Technology, Arasur. Their areas of interest are Cryptography and Network Security and Mobile Communication.



**Ms.K.Gugapriya** is pursuing her Final Year Bachelor Degree in the Department of Information Technology at V.R.S. College of Engineering and Technology, Arasur. Their areas of interest are Cryptography and Network Security and Mobile Communication.