

A Review on Implementation of Effective Airport Lighting System Using FPGA

Trupti R. Kadu¹ Prof. A.P.Thakre²

¹Student Department of Electronics and Telecommunication, Sipna College of Engineering and Technology, Amravati(M.S),India

² HOD, Dept. of Electronics and Telecommunication, Sipna College of Engineering and Technology, Amravati(M.S),India

-----***-----

Abstract - The major problem in 21st century is energy crisis mostly the electric energy crisis. The major source of electric energy consumption is lighting source. It is observed that about one third of global consumption of electricity is spent for lighting purpose specially at night at railway station, bus station, at home or at airport for proper reference of airplane for landing or take off to avoid distraction. So, development of more effective lighting source is important either by replacing existing light sources like fluorescent lamp or CFL with light source like LED to add more advantage such as less power, more safety or efficiently using the existing system. The project is concerned about an efficient automatic system for airport runway lights for night which save power, less costly and small. The implementation is done using FPGA which add advantage such as overall system become less costly, more efficient and small so that further work is simplified.

Key Words :Electric Energy, Airport, FPGA, Airport Runway Light

1.INTRODUCTION

Worldwide trends in the aviation industry indicate that monitoring and controlling airfield lighting systems increases the airport capacity and operation efficiency, improving the safety in air-traffic control and the aircrafts. Airport airfield ground lighting (AGL) systems are in charge of emphasizing the runway, giving visual reference of speed and alignment to aircrafts in the final stages of approaching, landing, and taxiing operations. The so-called marker lights, or beacons, are lamps installed in devices, which modify the pattern, intensity, color, and direction of the light emission. The number of beacons is variable (from 500 in small airports, up to 3000–4000 in the larger ones) and involves an enormous and expensive work of maintenance and conservation, mainly derived from the detection and location of burnt-out lamps. At an aerodrome opened for night operations has various runway and taxiway lights are

Threshold Lights- mark the beginning of the landing surface. They consist of four or more green lights, two on each side of the runway

Runway End Identifier Lights (REIL)-are installed to provide rapid and positive identification of the approach end of a runway and may be either omni or unidirectional

Runway Edge Light Systems- used to outline runway edges during darkness or restricted visibility and white in colour,

Runway Centerline Lighting System - are installed on some precision approach runways to facilitate landing under adverse visibility condition.

Touchdown Zone Lights (TDZL): Installed on some precision approach runways to indicate the touchdown zone during adverse visibility condition.

Taxiway Lights:

Taxiway Edge Lights: Outline edges of taxiways during periods of darkness or restricted visibility. They are omni-directional blue lights.

Taxi Centerline Lights -Facilitate ground traffic under low visibility conditions by illuminating the taxiway centerline, located along the taxiway centerline in a straight line on straight portions,

Runway Guard Lights:Runway guard lights are installed at taxiway/runway intersections Enhances visibility of taxiway intersections during reduced visibility Consists of either a pair of elevated flashing yellow lights on either side of the taxiway or a row of in-pavement yellow lights.

Problem Statement

Airports, large and small, use enormous amounts of energy every day and night. Due to the specific use airports serve, it is difficult to develop a new technology that fits in with technology already in place that does not interrupt the daily flows of traffic in and out of the airport. Airports pose a problem because they are nearly always turned on, which creates very large energy consumption and costs. This makes an airport a very good candidate for energy conservation technology.

Background of the Design Challenge

Airfield lighting is a vital part of an airport and a key in aviation safety. When the sun goes down or the weather takes a turn for the worst, pilots turn to airport lighting to make a safe landing and to navigate around the airport property. Federal Aviation Regulations state that lights may not be spaced any closer than 75 feet or more than 200 feet apart and with runways being anywhere from less than a mile long to over 3 miles long, there will be a substantial amount of lights, which in turn will use a lot of energy every single night. Though in a bad weather day and it could be a full 24 hours of lighting. By researching and replacing existing airport lighting system having florescent lamps by low power consumption, Eco friendly lights like LED and automatically control the runway lights as per the arrival of airplane using FPGA , it is a great and remarkable step to providing a carbon-free energy source that currently relies on expensive, non-renewable fossil fuels.

Problem Solving Approach:

The year by year ,electric energy crises hit a record high. Those , energy crises really showed the world that there is a need for research of using the new efficient electric energy sources so,that it can consume less electric power or making the electric sources automatic so that it may on when required and off automatically after use ,due to this the probability of electric energy to be waste is less and that it needs to be done quickly.

Airports across the world are some of the leading users of energy. They join the rest of the world in the energy crisis that has come to light of late, with good reason. Airports are some of the largest consumers of energy imaginable From terminals that are open twenty-four hours, airplanes burning thousands of pounds of fuel and lighting systems that guide those aircraft in and out of the airport safely. Hence in this project we have decided to only focus our efforts on making the existing airfield lighting of airport more effective in term of electric power consumption by using LED lights for lighting instead of the florescent lamp and on or off lights of airport runway automatically as per arrival of airplane.

LITERATURE REVIEW:

The airports especially use non-renewable resources constantly. Whether it's the airplane using fuel to move about the airfield or keeping the lights on in the terminal continuously, day or night. What other facility uses as much constant power as an airport? It's a challenge to find one. There are various literature proposed on this topic as the first is using the renewable resources like solar panel or wind energy for generation of electricity for lighting a airport. This work is done at in Aeronautics Division, College of Technology Kent State University, Kent[1]. In this work they specify that use of wind and solar renewable energy for lightning system but solar panel heat from the sun to operate and if the weather is overcast skies for a period of time, that system output will be greatly reduced and second problem is of cost as it implemented at San Francisco's case, In case of wind energy is Energy production which implemented at Denver International would depend on the weather making wind turbines not suitable for many areas. And hence there used a new renewable energy source as motion power.

The second literature given on this topic is by Joaquín Granado, Jorge Chávez, Antonio Torralba, and Ana Cinta Oria[2] specify that Reusing the AGL power distribution circuit to transmit control and supervision data is a non conventional PLC application that the authors survey in that literature . Due to the low bandwidth requirements of this application, narrow-band PLC

modems in the range 60 to 200 kHz are considered to be suitable for this application. The main elements of an AGL circuit have been analyzed and measured in the laboratory to obtain their SPICE models.

The article of ACRP Airport cooperative research program sponsored by FAA(federal aviation administration)[3] proposed that Light-emitting diodes (LEDs) are being used increasingly for many different safety-related applications including exit signs, road traffic signals, vehicle brake and turn lights, street lighting, and airfield lighting. LEDs have several characteristics that make them especially attractive for visual signaling applications: Durability and longevity as solid state devices, Wide range of available colors, Narrow band wavelength output resulting in saturated color appearance, Relatively low energy requirements, Immediate “switch-on” and “switch-off” time, longer operating lives, higher luminous efficacy (lumens per watt, lm/W), lower energy requirements.

The article proposed on the Field programmable gate array in safety related instrumentation and control application [4] as to develop an overview and understanding of the position of safety related systems built on FPGA technology (Field Programmable Gate Arrays). FPGAs have been gaining interest from the nuclear industry for a number of years. Their simplicity compared to microprocessor-based platforms is expected to simplify the licensing approach.

PROPOSED WORK

The system architecture of a FPGA approach for efficient lighting system for airport runway is as shown in figure consisting of airport runway and runway lights(approach indicator). The lights on runway is controlled as per arrival and movement of airplane.

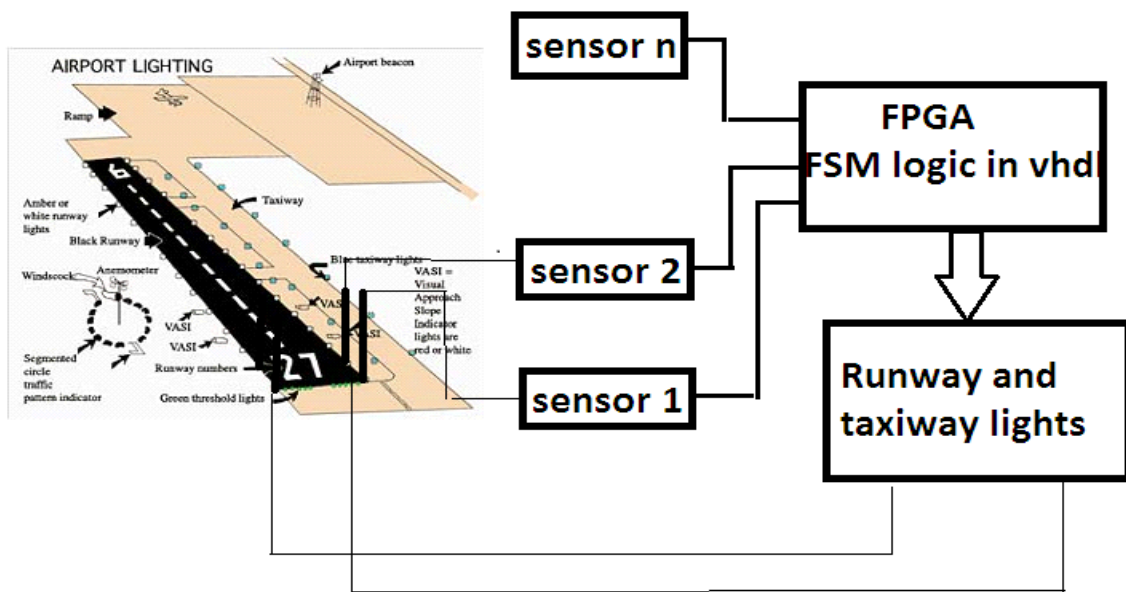

Figure: 1 system overview

Airports across the world are some of the leading users of energy. They join the rest of the world in the energy crisis that has come to light of late, with good reason. Airports are some of the largest consumers of energy imaginable. From terminals that are open twenty-four hours, airplanes burning thousands of pounds of fuel and lighting systems that guide those aircraft in and out of the airport safely. Hence in this project we have decided to only focus our efforts on making the existing airfield lighting of airport more effective in term of electric power consumption by using LED lights for lighting instead of the florescent lamp and on or off lights of airport runway automatically as per arrival of airplane for detecting the arrival of plane the objects sensors are required as shown in figure 1 and controlling logic in given in HDL using FSM. The proposal will feature runway, taxiway and approach lighting systems at airports and a way to power saving through this new technology. The project goal is

to provide an understanding of this new system and how it works, to bring it into the spotlight at airports across the country to take advantage of a huge resource they already have; while providing an added benefit of safety for it's customers.

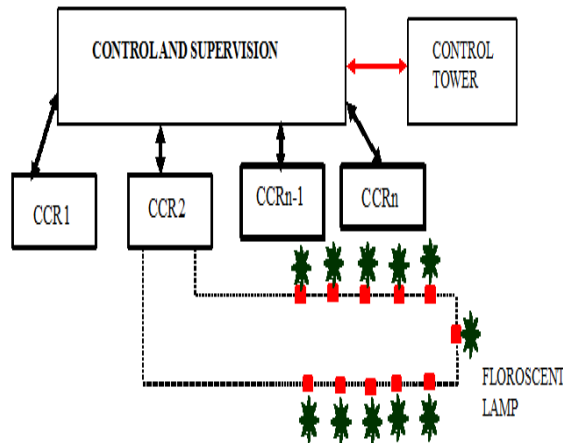

Figure 2a) existing airfield ground lighting system

The figure2a shows the existing airfield ground lighting system having control and supervision block with florescent lights as a airfield ground lights. As discussed earlier the limitation of existing airfield ground lighting system the proposed airfield ground lighting system is shown in figure 1b. There are various methods of control and supervision of airfield ground lighting system that is either using microprocessor , micro controller, power line communication or HDL(FPGA,CPLD). Here we implement the airfield ground lighting system's control and supervision using HDL(FPGA) because of various advantages like less Time to Market, less Cost, higher Reliability.

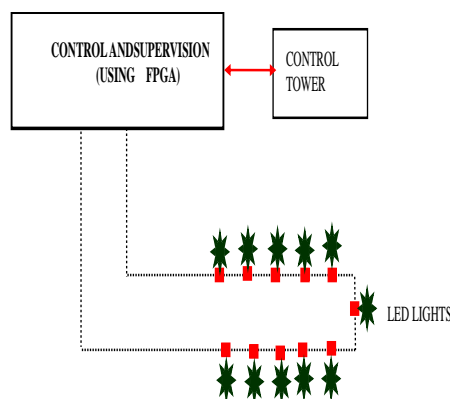
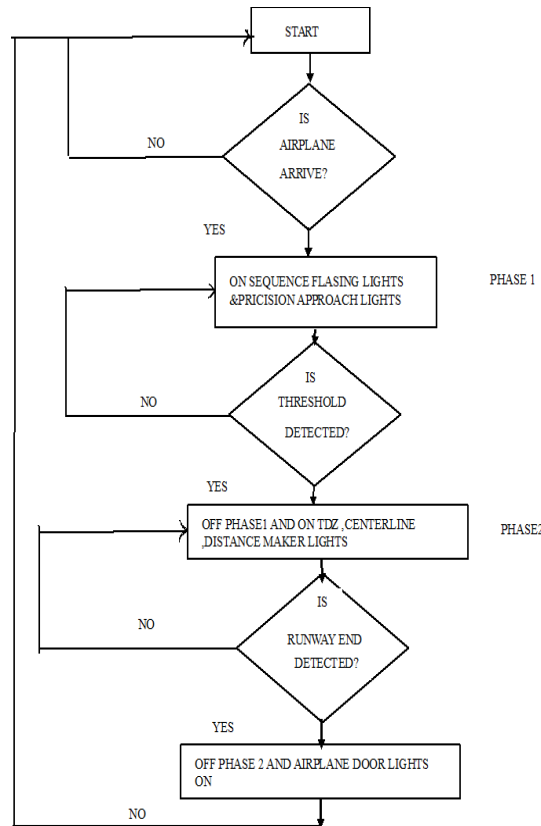

figure2b)proposed airfield ground lighting system

Working approach:

As specified earlier in this project we are implementing a energy efficient as well as automatic airport runway lighting system. For implementing this approach we are using the finite state machine .The fsm code is written in vhdl and analysed using two software platform -Modelsim and Xilinx. The flow chart specifies the working approach of project as here we specifies the three sensing points at arrival of airplane ,at threshold and at end of runway .The object sensor used for arrival of airplane continuously scan is airplane arrive ? if airplane arrive lights on runway before threshold is ON then again check Is threshold is detected? If threshold is detected then OFF lights before threshold and ON lights after threshold and runway end lights also ON .now check airplane reach at end of runway if yes then on only lights at and near door and off all other lights on airport runway.

Flow chart:



CONCLUSION:

Our project is prototype that concluded that the implementation of control and supervision of airport lighting system using FPGA technology and replacement of runway lights with LED at airports can be a viable long-term solution for effective energy conservation. The technology for airport runway lights is automatic as per arrival of airplane and saved large amount of electric power approximately 1.9×1020 joules, US\$1.83 trillion financial savings, 10.68 gigatons reduction of carbon dioxide emissions, and 962 million barrels less consumption of crude oil for single LED is proposed in one of the literature as in this project we are replacing all airport runway lights by LED and hence there is power saving upto great extend .

The great part about it is that the airport not only benefits, but the entire environment around the airport will benefits.

REFERENCES:

1. Dr. Isaac Richmond Nettey " Lighting Airfields through Harvested Kinetic Energy from Vehicular Traffic design" 14 th April 2010.
- 2.JoaquínGranado, Jorge Chávez, Antonio Torralba, and Ana CintaOria" Modeling Airfield Ground Lighting Systems for Narrowband Power-Line Communications"
- 3.Airport Technology(2008, January 07). Lighting the Way . Airfield Ground Lights ,Retrieved from <http://www.airport-technology.com/features/feature1422>
- 4.Eric Monmasson,Marcian Cirstea "FPGA Design Methodology for Industrial Control system a review".
- 5.Airport Visual,AidTechnologies, ICAOSouth American , workshop artical May 7-11, 2012

6. Jasveer Singh, T. Jethra, Sachin B. Patkar, Shamik Datta "Remote Triggered FPGA based Automated System"
7. Mohsen Kavehrad, Pennsylvania State University "Sustainable Energy-Efficient Wireless Application Using Light"
8. Fabio Fresch Massimo Mitolo, Riccardo Tommasini "Electrical Safety of Aeronautical Ground Lighting Systems"
9. Alexander Rizkin, Rendon Beach, Calif "INTEGRATED APPROACH LIGHTING SYSTEM"
10. A.B. Snedeker "Airport Rocks Eco-Friendly Runway Lighting"
11. Ninad Saraf, Rohan Salvi, Nimesh Salunkhe, Ritvij Sahasrabudhe "Airfield Lamp Monitoring & Control Systems"
12. Z. Jundong, R. Guang, and S. Peiting, "A monitoring and control system based on local network for airfield lighting," in Proc. Int. Conf. Info-Tech and Info-Net, Oct. 2001, vol. 4, pp. 192-195.
13. K. Lee, "Integration of aviation lighting system and computer controlled monitoring system," in Proc. IEEE Int. Conf. Systems, Man, and Cybernetic 1996, Oct. 1995, vol. 2, pp. 1132-1137.
14. "Aerodrome Design Manual, Part 4, Visual Aids," 4th ed. Int. Civil Aviat. Organiz., 2004.
15. "Design and Installation Details for Airport Visual Aids (150/5340-30D)," Fed. Aviat. Admin., Airport Safety and Standards (ASS), Sep. 2008, FAA.