

Greenhouse Surveillance System Using Smart Phone

Shubhangi Ghatage¹, Snehal borate², Rupali Kale³, Prof. R. Rashmi⁴,

^{1,2,3} Department of Electronics & Telecommunication, PVPIT, Bavdhan, Pune

⁴ Assistant Professor, Department of Electronics & Telecommunication, PVPIT, Bavdhan, Pune.

Abstract - This paper designs a novel wireless surveillance system in greenhouse, using smart phone in order to solve long-existing problems in traditional systems, such as high maintenance cost, low robustness and mobility, etc. The introduction of smart phone has remarkable meaning in the design of greenhouse surveillance systems, as it could simplify the design and also extends the function. We here propose the well monitoring system in greenhouse using Android Application. In this system android application will be operated by user for cutting the flower in the greenhouse with the help of scissor mounted on mechanical structure. The whole system will be operated by low power microcontroller PIC16F877A.

Key Words: Green House, GSM Monitoring System, wireless sensor network, surveillance system.

1. INTRODUCTION

Previously, human labor plays major role in the monitoring farm and plants in the agriculture field. For some crucial plants such as vegetarian and flowers plants, which need 24 hours attention from human so there came an idea in mind about minimizing human efforts and providing that the plant quantities and qualities are controlled with proper management by the collected data and information from the fields. This will provide enormous foundation for future growth and future development of their plants in the green house. However, with the increasing size in farming areas, this type of manual practice is increases time consuming and cost of the labor [3].

The focus of Greenhouse automation division is the optimization of environmental conditions for better plant growth. The aim of the paper is to control the devices or equipment's from the remote place through a web page. The main advantage of this technique is that the devices connected to the web server need not store the offline data or have the software required to view the data. In this way the devices connected need not store or run the software whenever they want to view the data. All the required software and the data are stored in the web server and the Client devices need not store the data neither the software. Also the devices can view the required data anywhere from the world as these devices are connected via Internet. The nature and complexity of the software systems had changed significantly in the last 30 years. The previous applications run on single processor and produce fixed output. But with

the advancement in the technology application are having the complex user interface and these applications run on the various systems simultaneous like applications which support client server architecture. Here all the devices, which are to be controlled, are connected to the relays, there are four relays connected and are controlled automatically for different parameters like Temperature, Humidity, Soil Moisture and Light Intensity [12].

Our system consists of basically two main units

- User's smart phone.
- A buggy Unit.

We are going to develop an Android Application which will be operated by user for cutting the flowers in the greenhouse with the help of that buggy. Android application will have total six buttons on the screen. All buttons are used to give commands to the buggy.

This paper consisting of section 2 describes existing system and literature review. Section 3 explains proposed system, system architecture of proposed system. Section 4 is concluding with future work of this system.

2. EXISTING SYSTEM

Now a day Greenhouse Surveillance is done by man power that is by farmers. Therefore maintenance of the greenhouse system requires large number of human efforts as well as money. Number of mistakes is done by these workers at the time of maintaining the system. To identify these mistakes another worker are required and thus this cycle goes on, which will cause the wastage of human efforts, money, time and finally loss of owner. The monitoring and GSM systems and developed in this project is for use in green house applications, where real time data of climate conditions and other environmental properties are sensed and control decisions are taken by monitoring system and they are modified by the automation system and sends SMS that what operation is performed by them to user.

The Qin Ningning, Li Dong, Xu Baoguo define Greenhouse Surveillance System on Wireless Sensor Networks [1]. In that they proposed the wireless communication protocol including transmission and data format applicable in the greenhouse. In the part of experiments showed sleep-wake mode increased lifetime of sensors quite efficiently. Their design simplify the design of communication circuitry so as to reduce the period of the whole system implementation, Increased function and performance of interfaces, then facilitate the maintenance and update of the system.

The Gao Junxianga, Du Haiqing define design of Greenhouse Surveillance System based on Embedded Web Server technology [2]. Based on ARM-Linux development environment, this paper constructs embedded web server and use it in acquisition and transmission of greenhouse information. The system could transmit the collected information effectively with benign stability and expansibility. Microprocessor S3C2440 based on ARM9 is used as the system processing unit, its rich resources can not only realize the system function, but also facilitate the system expansion in the future. Embedded web server Boa and embedded database management system. The working performance of the system is quite stable and can reach the design requirements in real-time data acquisition and remote control.

The table 1.1 shows difference between PIC16F877A and ARM.

Table -1: Comparisons of PIC and ARM

PIC16F877A	ARM
Generally have 33I/O pins	36I/O pins 32 bit
10 bit ADC	10 bit ADC
Serial TXD and RXD pins	2 URAT
Programmable memory size 8k *14	On chip SRAM of 8kb-40kb
Operating voltage 2-5 volt	Operating voltage 3-3.6v

3. PROPOSED SYSTEM

We are going to develop an Android Application which will be operated by user for cutting the flowers in the greenhouse with the help of buggy like structure. Our system consists of basically two main units one of them is user's smart phone and second unit is buggy like mechanical structure. To transfer the data through wireless communication to application software at Android smart phone and it controls the module.

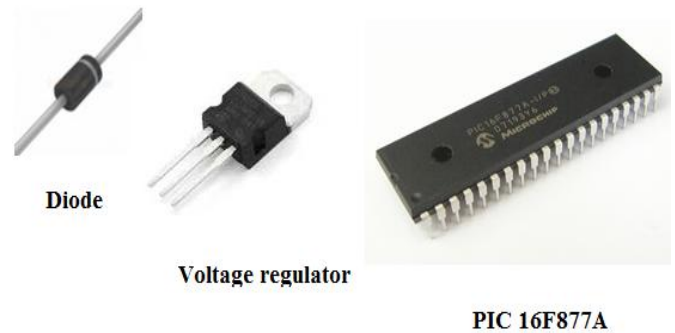

Fig -1: Hardware Requirements

The Fig 1.1 shows hardware requirement of system. We have used Diode 1N4007 in power supply section for rectification of input power supply. The Features of Diode consisting of Diffused Junction, High Current Capability and Low Forward Voltage Drop, Surge Overload Rating to 30A Peak, Low Reverse Leakage Current.

In that LM7805 series of three terminal positive regulators are available in the TO-220/D-PAK package and with several fixed output voltages, making them useful in a wide range of applications. Each type employs internal current limiting, thermal shut down and safe operating area protection, making it essentially indestructible. If adequate heat sinking is provided, they can deliver over 1A output current. Although designed primarily as fixed voltage regulators, these devices can be used with external components to obtain adjustable voltages and currents.

PIC 16F877A 8 bit microcontroller having specification consisting of operating speed DC – 20 MHz clock input, DC – 200 ns instruction cycle, Up to 8K x 14 words of Flash Program Memory, Up to 368 x 8 bytes of Data Memory (RAM), Up to 256 x 8 bytes of EEPROM Data Memory, Low-power, high-speed Flash/EEPROM technology, Fully static design, Wide operating voltage range (2.0V to 5.5V).

The hardware unit of the prototype of the system is represented by the block diagram. It contains a PIC16F877A microcontroller as the main processing unit. Buggy is mechanical structure which will move in the upward and downward direction on the soil of the greenhouse. This moving is done by the two motors. On the top of the buggy, scissor is connected for cutting purpose. This scissor will move only in angle of 45 degree with the help of one motor. And one motor is used for movement of the scissor. Therefore total four motors are required for this unit. LCD will display the counting of flowers. Motors cannot be connected to the controller directly so that relay drivers are used. Four relay drivers are used for four motors connection to the controller. The communication between the buggy and smart phone is done by Bluetooth device.

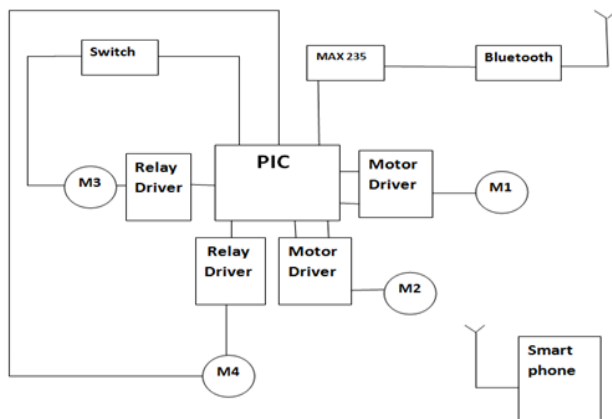

Fig -2: System Architecture of Surveillance systems in greenhouse using smart phone

3.1 System Architecture

- Smart phone We are develop Android application will be operated by user for cutting the flowers in the greenhouse with the help of buggy like structure. We are using Android 4.2 version and application is written primarily in the java programming language.
- Hardware description Buggy is mechanical structure which will move in the upward and downward direction on the soil of the greenhouse
- Microcontroller we are using PIC (16F877A) as microcontroller. We select this microcontroller because of availability of I/O pins is more and sufficient memory for programming purpose
- Motor We are used brushless DC motor. This moving is done by the two motors. On the top of the buggy, scissor is connected for cutting purpose. This scissor will move only in angle of 45 degree with the help of one motor. And one motor is used for movement of the scissor. Therefore total four motors are required for this unit Motors cannot be connected to the controller directly so that relay drivers are used. Four relay drivers are used for four motors connection to the controller. Two relay driver used as switch
- Bluetooth module: We are using Bluetooth module(HC05). The communication between the buggy and smart phone is done by Bluetooth device.
- Max 232: It standard protocol. It use to convert RS 232 signal into TTL logic. the communication between the Bluetooth module and PIC controller is done by Max 232.

3. CONCLUSIONS

There are number of design are built in this automation field but this is system design which are operated in smart phone. Users present at the green house and control the buggy structure. This Android Application which will be operated

by user for cutting the flowers in the greenhouse with the help of buggy like mechanical structure.

This system may improve the existing technology in the field of wireless communication and with the wide improvement of GSM technology which can improve Short Message Service with the help of embedded technology anything may become possible and easy.

REFERENCES

- [1] Qin Ningningi, Li Dong, Xu Baoguo, "Greenhouse Surveillance System on Wireless Sensor Networks", International Conference on Networking and Digital Society, Date 30-31 May 2010.
- [2] Junxianga, Du Haiqing, "Design of Greenhouse Surveillance System based on Embedded Web Server technology", Published by Elsevier Ltd, Proceeding Engineering 23 (2011).
- [3] Ning Wang, Naiqian Zhang, Maohua Wang, Wireless sensors in agriculture and food industry-Recent development and future perspective[J], Computers and Electronics in Agriculture, 2006, vo1.50,pp. 1-14.
- [4] J. Li, S.F. Du. Development of Intelligent Greenhouse Controller[J], Microcomputer Infonation,2006, vlo.5, No.2,pp. 65-66. -R. Qi, 1.1.
- [5] Qin, x.Y. Wang. Development of greenhouse intelligent controller based on CAN bus[J], Chinese Journal of Scientific Instrument, 2005,vol.1.
- [6] H. Karl, A. Willig. Protocols and architectures for wireless sensor networks [M]. Publishing house of electronics industry, 2008.1, Beijing
- [7] "Microcontroller and Embedded Systems" By Muhammad Ali Mazidi, Rolin McKinlay, Danny Causey, Published June 28th 2012 by Prentice Hall.
- [8] "URL:http://wikipedia.org/wiki/PIC/microcontroller http://www.developershome.com/sms/GSMModemIntro.asp", refereed on dated 26 Jan, 2016.
- [9] "URL:http://developer.android.com/guide/topics/wireless/bluetooth.html", referred on dated 15 Feb, 2016.
- [10] "URL: http://developer.android.com/reference/android/hardware/Camera.PreviewCallback.html", referred on dated 15 Feb, 2016.
- [11] "URL: http://developer.android.com/reference/android/net/wifi/package-summary.html", referred on dated 15 Feb, 2016.
- [12] Y.R.Dhumal, J.S.Chitode, "Green House Automation using Zigbee and Smart Phone", International Journal of Advanced Research in Computer Science and Software Engineering, Volume 3, Issue 5, May 2013