

UNIFORM STACKING OF BATCHES IN A BANBURY MIXER FOR ENHANCED PRODUCTION

Vishnu C¹, Sudharshan Krishnan², Rohith R Unni³, Sree Vallabh M⁴, Prashanth Premraj Menon⁵, Sruthy Menon⁶

^{1, 2, 3, 4, 5} U.G Scholar, Department of Mechanical Engineering, NCERC, Kerala, India

⁶ Assistant Professor, Department of Mechanical Engineering, NCERC, Kerala, India

Abstract - The purpose of our project is to implement a technique for stacking of batches in banbury mixer automatically. The implementation of the desired technique will help in the uniform stacking of each batch coming out of the banbury mixer which goes in to the extruder. At present the batches coming out are arranged uniformly by manual work which is a very difficult and tedious. If this unarranged batches enter into the extruder it will result in uneven cutting, jamming and affect the homogeneity which will lead to wastage of materials. Implementing this technique help to overcome the problem and enhances production.

Key Words: Banbury, cooling rack, proximity sensor,

160-166°C is obtained then according to requirement some mix are sent to batch off and some into final batch.

THIRD STAGE: Batch off mill –First the mixed compound is passed through rollers and made into continuous sheets then it is passed through oil and soap solution and it enters into the cooling rack as loops. The sheets are cooled with the help of cooling fan (total number of fan-32) which is present on both sides of cooling rack. It passes through conveyor belt into wig wag. Then it is stacked in to skid.

FORTH STAGE: The stacked material on the skid is transported with the help of skid pallet trolley to the mill.

1. INTRODUCTION

Industrial mixer: Industrial mixers and blenders are used to mix or blend a wide range of materials used in different industries including the food, chemical, pharmaceutical, plastic and mineral industries. They are mainly used to mix different materials using different types of blades to make a good quality homogeneous mixture.

They can operate at different temperatures and pressures for mixing different solutions and can also have internal or external heating systems added to them.

The Banbury mixer remains the first choice for diverse applications in the tyre industry because it is ideally suited to the specific requirements of multi-step mixing applications. Criteria such as good intake and discharge behavior, excellent dispersion and distribution quality, and optimal cooling behavior guarantee efficiency

1.1 PRODUCTION STAGES

FIRST STAGE: The first process in banbury machine is Carbon charging. In carbon charging different types of carbon according to the properties required, a particular type carbon is used, and then it is processed to the next stage.

SECOND STAGE: There are two master batches and two final batches. In master batch compounds like synthetic rubber, natural rubber, silica, Sulphur, etc. are mixed together with actuating motion of ram. In this process temperature up to

2. PROBLEM INVOLVED AND ITS EFFECTS

•Off Centering

Initial problem observed was off centering of sheet while it passes through the conveyor belt after the cooling rack.

•Height Difference

Height difference between the wig wag and the skid pallet causes non-uniformity in stacking.

EFFECTS

•Homogeneity

If the batch is not uniformly stacked, when it fed into the mill through auto stacker homogeneity of the mix will be lost.

•Jamming

When it is passes through the roller due to non-uniform in stacking jamming occurs between the rollers which can cause damage to the machine.

•Quality

If the stacking is not uniform the quality of the final product will be lost.

3. CORRECTIVE MEASURES

The main aim of implementation of this project or design is for uniform stacking of batches in a banbury mixer.

The solution to the project is achieved by application of a design which automatically enables uniform stacking of batches in banbury mixer.

The technique followed presently is merely a manually operated system in which the stacking is basically done with the help of workers employed in these sections because of which the stacking is non-uniform in nature which causes

blockage of the material within the process, hence the homogeneity of the compound is lost

4.DESIGN DESCRIPTION

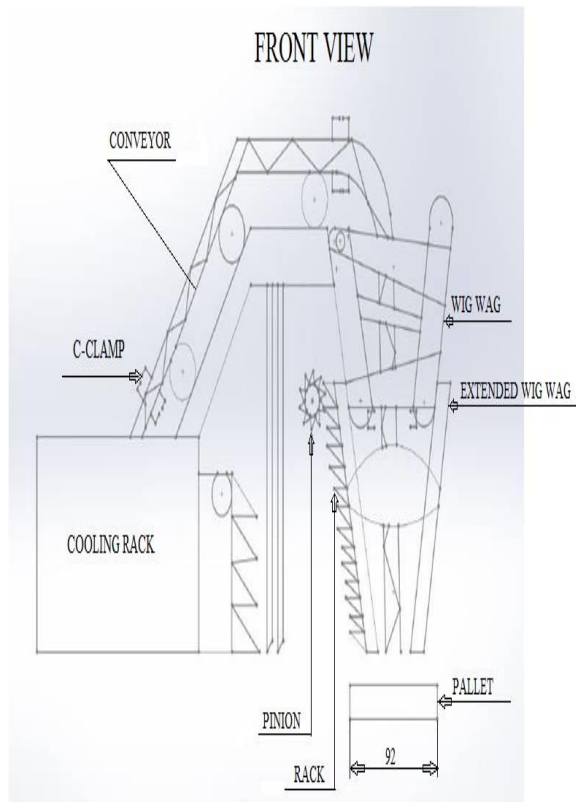

Fig -1 Schematic Diagram

The problem of off-centering is corrected by the use of c-shaped clamps at the sides of the conveyer belt because of which the compound flows through the path which it is actually desired to flow.

The problem of height difference is tackled by the aid of extended portion of wig wag thus eliminating the fall of compound under free fall due to gravity causing non-uniformity of stack in the pallet.

The extended portion of wig wag is adjustable with the help of rack and pinion mechanism actuated by a motor provided, this extended portion of wig wag is basically a T-shaped plate of aluminum.

A proximity sensor is placed at the top of wig wag system in order to ensure that the extended portion of wig wag stops at a vertical height after stacking is done. This height is actually set in order to make sure that the extended portion of wig wag doesn't go beyond that point.

4.2. MOTOR SPECIFICATION

TO CALCULATE MOTOR POWER

$$POWER= M.G.V(I)$$

M =mass of the extended portion

=5kg.

G =acceleration due to gravity=9.81m/s².

V =velocity of the extended portion=h/t.

H =height moved in unit time, t.

Therefore,

$$P =5 \times 9.81 \times (0.02/3) =0.327kw$$

=0.438hp.

4.1 COMPONENTS OF DESIGN

•Cooling Rack

It consists of 32 cooling fans through which the rubber sheet goes through the rack in the form of loops.

•C-Shape Clamp

It is used to prevent the off centering of the rubber sheets as it goes through the conveyor.

•Wig Wag

It is used for stacking of rubber sheets



Fig -2 stacking

- Extended T-Shaped Plate

This is implemented to provide the uniform stacking of rubber sheet.

- Rack and Pinion Mechanism

This mechanism is provided for the up and down motion of the extended plate.

- Electric Motor

0.5 HP DC electric motor is provided to power the motion to rack and pinion mechanism

- Connecting Rod

It is used to connect the two t-shaped extension plates.

- Proximity Sensor

It is used to control the vertical motion of the extended wig wag within a certain limit.

[7] Stven G Gould, James E Hertel (1994) "Apparatus and method for stacking" Paper Converting Machine Company, United States (CA 1333180 C).

[8]] Robert A Morgan, George L. Matlock, Lynn T. Beckwith (2000) "Zero feed interrupt sheet stacker" Geo M. Martin Company, California (US 6042108 A).

5.ADVANTAGES

- 1.Simple Mechanism
- 2.Cost Efficiency
- 3.Minimized Labor Effort
- 4.Uniform Stacking
- 5.Avoid Off Centering
- 6.Automated Mechanism
- 7.High Production Rate
- 8.Durable

3. CONCLUSIONS

The problem faced in stacking process was properly evaluated and thereby the correct measures were taken by adopting a design which could provide a way for uniform stacking of batches in the banbury mixer. There by increasing the productivity by minimizing the losses.

REFERENCES

- [1] Sharma Anil R (2014),"A Review On Rubber Compound Mixing In Banbury Mixer At Tire Industries" B.Tech. (Mechanical Engineering), Final Year, Lovely Professional University, Phagwara, India
- [2] I.R.Iran, (1995) A Transient Finite Element Model of Mixing of Rubber Compounds in a Banbury Mixer"by Mir Hamid Reza Ghoreishy, Polymer Research Center of Iran, Tehran.
- [3] Grenzebach Maschinenbau GmbH (2012) "Device for automatically sorting glass plates" Germany (US 8210339 B2).
- [4] Mark Sisk (2005) "Method and apparatus for stacking small sheets of glass" Cardinal FG Company, Minnesota (US 6957944 B2).
- [5] Hodgkinson J, Morey R (1973) "Stacking of sheet" Pilkington Brothers Ltd, United Kingdom (US 3713650 A).
- [6] James R Michler, Jeffrey A Gendron, Dennis P Couturier (2004) "Apparatus and method for stacking sheets discharged from a star wheel assembly" C.G.Bretting Manufacturing Co, Inc, United States (US 6832886 B2).