

MOTOR VEHICLE SECURITY SYSTEM

Aparna V A, Abhishek K, Abhay Krishna K B, Harsha K, Ann Mary Raphael

Aparna V A, BTech student, ECE, MET's school of engineering, Mala, Kerala, India

Abhishek K, BTech student, ECE, MET's school of engineering, Mala, Kerala, India

Abhay Krishna K B, BTech student, ECE, MET's school of engineering, Mala, Kerala, India

Harsha K, BTech student, ECE, MET's school of engineering, Mala, Kerala, India

Ann Mary Raphael, BTech student, ECE, MET's school of engineering, Mala, Kerala, India

Abstract – Road accidents are increasing day by day. Major of these road accidents are caused by two wheelers or Motor vehicles. An innovative concept proposed in this system is the complete safety of the bike riders. This system makes it compulsory for the riders to wear the helmet and not to use the vehicle when the rider is in drunken condition. A password locking system and anti-theft measures are also implemented in the vehicle to ensure the safety of the vehicle. GSM alerts the user of the vehicle if any theft of the vehicle occurs by sending a message to the user's mobile.

Key Words: Motor vehicle, Password locking, Anti theft measures, GSM.

vehicle is changed, then immediately a SMS is sent to the owner's mobile through GSM. Accelerometer sensors are used to check the titling of the vehicle. Helmet sensing can be done by temperature sensor. MQ3 sensor is used for alcohol detection. RF module is used for wireless transmission between the vehicle and helmet unit. The data is sent to the PIC microcontroller and it checks whether the driver is drunk or not, presence of helmet. It also detects the change of position in the vehicle along with password locking system condition. All of this status is displayed in LCD.

1. INTRODUCTION

In this hustle and bustle world it has become necessity to be aware of one's safety on roads. Nowadays most of the accidents are for the two wheelers or to the motor vehicles, which is mainly because of the decrease usage of helmets and the consumption of alcohol while driving. As a remedy to this situation most of the counters insist the motor riders to wear the helmet and not to ride the bike when the rider is in drunken condition. But most of them are neglecting these rules. Considering all these situations this paper gives a remedy to the above mentioned problem.

1.1 OVERVIEW

This project implements complete safety for those who afford motor vehicles. This system mainly consists of two major units namely helmet unit and vehicle unit. It checks whether the rider is drunk or not, the presence of the helmet and the position of the vehicle. Here a password locking system is implemented in the bike, for the security of the bike. System makes it mandatory for the riders to wear the helmet before starting the vehicle and the rider shouldn't have consumed alcohol. If rider fails to do any of the mentioned things above the vehicle cannot be started. If helmet is worn after the consumption of alcohol, then buzzer present in the bike will beeps. The status will be always shown in the LCD display. If the vehicle is parked and someone tries to take off the vehicle, the position of the

2. EXISTING SYSTEM

The general transportation the people are using today are motor vehicles. Motor vehicle accidents and motor vehicle theft is one of the problems world is facing now. Several suggestions were given to reduce motor vehicle accidents and to implement antitheft measures of vehicles. One of which was the eye retina scanner and thumb scanner which will be started when vehicle's ignition is turned ON. The system will scan the eye retina and thumb impression of driver. Scanned patterns will be sent to a central processing unit. If central processing unit is working properly the regular functioning can be done. But if a hardware failure occurs, the device will never give an indication to the user that the system got failed. In this world there are so many inventions to protect the vehicles from unauthorized users, but that should not create problem for the authorized users. In such a case forget about the thief, the genuine user itself cannot even start the vehicle. But in this paper anti-theft measure such as password locking, accelerometer detection is installed in the vehicle to make it secure from the unauthorized users.

3. PROPOSED SYSTEM

In this paper the proposed system is aimed to design and develop advanced vehicle locking, alcohol detection and encourages rider to wear helmet, which overall provides safety and security of the rider. The entire system is divided into two units. One is implemented in the helmet, which consists the transmitter and other in the bike, which consists of a receiver.

3.1 TRANSMITTER BLOCK DIAGRAM

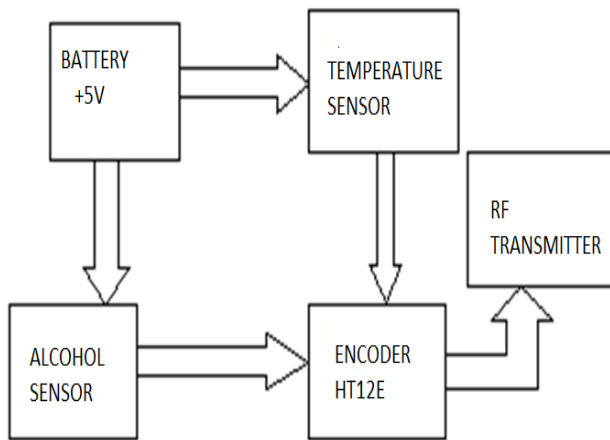

ALCOHOL SENSOR

MQ-3 semiconductor sensor is used for alcohol detection. When the presence of alcohol is detected, then the sensor's conductivity will be higher. Change of conductivity to correspond output signal of gas concentration is done here. MQ-3 sensor has high sensitivity to alcohol, and also has good resistance to disturb of gasoline, smoke. It's a low cost device having applications like vehicle alcohol detector and portable alcohol detector.

TEMPERATURE SENSOR

Temperature sensor is used for the detection of presence of helmet. Thermistor is used as temperature sensor here. It is a type of resistor whose resistance is dependent on temperature, than in standard resistors. It is widely used as inrush current limiter, temperature sensors, self-regulating heating elements

RF TRANSMITTER

RF module (TX/RX) is utilized here for making wireless transmission from the helmet section to vehicle unit. These signals are transmitted at a frequency of 434MHZ. A receiver can receive these signals only if it is configured for this frequency. This system mainly allows one way communication between two nodes, for transmission and reception. The transmitter module takes these serial inputs and transmits these signals through RF and these signals are received by the receiver module placed at the vehicle. This radio frequency (RF) transmission employs Amplitude Shift Keying (ASK) with transmitter/receiver (TX/RX) operating at 434MHZ.

ENCODER

Here the RF module has been used in conjunction with a set of four channel encoder/decoder ICs. HT12E is used as encoder here. The encoder converts the parallel inputs into serial set of signal, which is transferred through RF to the reception, which is implemented on the vehicle unit.

3.2 RECEVIER BLOCK DIAGRAM

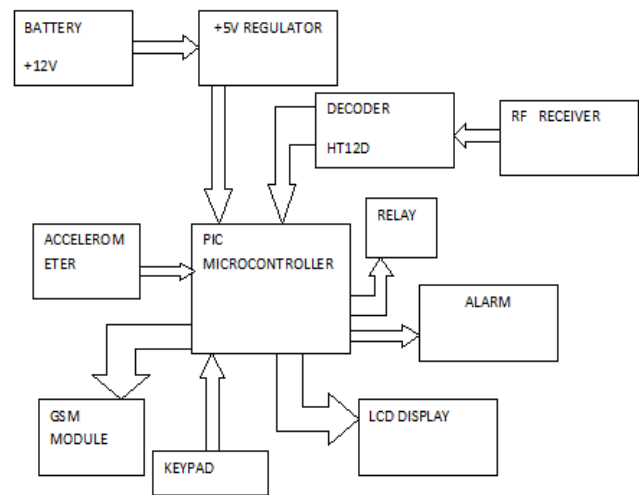

DECODER

HT12D is used as decoder IC. The decoder is used after RF receiver to decode the serial format and to retrieve the original signals as output. These outputs are observed by corresponding LEDs.

PIC 16F877A

40-Pin PDIP

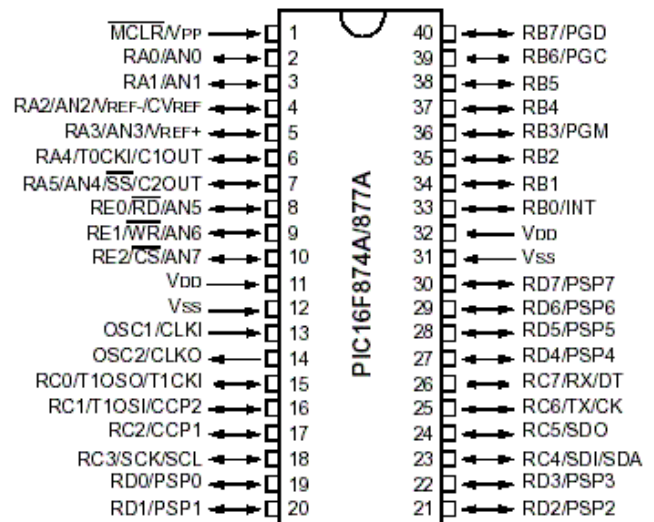

PIC 16F877A is the main component of the receiver section. It has high performance RISC CPU, 8K x 14 words of FLASH memory and 368 x 8 bytes of Data Memory (RAM). Its features are Power-On Reset (POR), Power-up Timer (PWRT), Oscillator Start-up Timer (OST), Watchdog Timer (WDT), three timers, Synchronous Serial Port (SSP), Universal Synchronous Asynchronous Receiver Transmitter (USART), Parallel Slave Port (PSP), 8-bits wide with external RD, WR and CS controls.

ACCELEROMETER

Accelerometer used here is Triple Axis Accelerometer module MMA7260Q Accelerometer. It is a sensing element which measures vibrations, shocks, tilt, impact and motion of an object. This Triple Axis Accelerometer reads off the X, Y and Z acceleration as analog voltages and by measuring this amount of acceleration due to gravity.

LCD DISPLAY

A 16 x 2 LCD display is used here. 16 characters per line and there are two such lines in this LCD display. Here each character is displayed in 5 x 7 pixel matrix.

GSM MODEM

It is a wireless modem that works with GSM wireless network. GSM is used here to give SMS to the owner of the bike if any theft occurs.

APPLICATIONS

- Used in motor vehicles to ensure safety of the rider.
- Alcohol detector can also be implemented in cars

3. CONCLUSIONS

This paper propose a new technique which is implemented with the help of PIC 16F877A, which acts as brain. Temperature sensors are used to detect the presence of helmet. MQ-3 semiconductor sensor detects the presence of alcohol. To make the system more secure a password locking system is implanted. Accelerometer connected to the system will detect the tilting of vehicle when it is in parking mode. The GSM module sends message to owner's mobile for considerable tilting of the vehicle. The working of GSM module is verified by interfacing the hyper terminal in PC. This low cost, rugged implementation seems to enhance the road safety.

REFERENCES

- [1] Radha Krishna Murthy Y, Ravindra Babu, "Alternate Method for the failure of Anti-theft Device used in Motor Vehicles" International Journal of Computer Applications, Vol. 13, No.6, pp: 23-23, 2011.
- [2] Kunjal P Tanna, Preethi Kumar, Subha Narayanan, "Instant Theft Alert and Tracking System in Car", International Journal of Computer Applications, Vol. 1, No. 21, pp: 29-34, 2010.

- [3] Vinod Kumar Sadagopan, Upendran Rajendran, Albert Joe Francis, "Anti-Theft Control System Using Embedded System", IEEE International Conference on Vehicular Electronics and Safety, Beijing, pp: 1-5, 2011.
- [4] Jiangpeng Dai, Xiaole Bai, "Mobile phone drunk driving detection", Pervasive Computing Technologies for Healthcare 2010, 4th International IEEE Conference March 2010, pp: 1-18.
- [5] Ali Rahnamai, Farnood Khoshnevis, Mina Vajdi, "A Design for Car Anti-Theft system using Cell Phone", International Journal Of Advanced Scientific Research And Technology, Vol. 1, No. 2, pp: 1-5, 2012.

BIBLIOGRAPHY



Ms. Aparna V A
BTech, Student, Electronics &
Communication Engineering
MET's School of Engineering
Mala, Kerala, India



Mr. Abhishek K
BTech student, Electronics &
Communication Engineering
MET's School of Engineering
Mala, Kerala, India



Mr. Abhay Krishna K B
BTech student, Electronics &
Communication Engineering
MET's School of Engineering
Mala, Kerala, India



Ms. Harsha K
BTech, Student, Electronics &
Communication Engineering
MET's School of Engineering
Mala, Kerala, India



Ms. Ann Mary Raphael
BTech, Student, Electronics &
Communication Engineering
MET's School of Engineering
Mala, Kerala, India