

# A Robust, Low Distortion CMOS Current Driver Circuit for Wideband Frequencies

S.Md.Imran Ali<sup>1</sup>, Shaik Naseer Ahamed<sup>2</sup>, P.Vamshi Krishna Reddy<sup>3</sup>, R Siva Prakash Reddy<sup>4</sup>

<sup>1</sup>Assistant Professor, Dept, of ECE, BRINDAVAN Institute Of Technology & Science-KNL, A.P, India

<sup>2</sup> Assistant Professor, Dept, of ECE, SAFA College Of Engineering & Technology-KNL, A.P, India

<sup>3</sup> Student, Dept, of ECE, BRINDAVAN Institute Of Technology & Science-KNL, A.P, India

<sup>4</sup> Student, Dept, of ECE, BRINDAVAN Institute Of Technology & Science-KNL, A.P, India

**Abstract** - Multi frequency Electrical Bio-impedance (MEB) has been widely used as non invasive technique for characterizing tissue. Most MEB systems use wide band current sources for injecting current and instrumentation amplifiers for measuring resultant potential difference. Tissue electrical properties exhibit frequency characteristics over a broad bandwidth (typically 1KHz to 10MHz). Such applications should possess high output impedance and low distortion wide band accurate ac current drivers. An integrated current driver that fulfils the requirement of maximum output current of  $356\mu\text{A}$  p-p, along with measured total harmonic distortion below 0.1% at 10MHz is presented in here. The circuit uses negative feedback to accurately set the output current amplitude into the load. The circuit is used for use in active electrode applications.

**Key Words:** Active electrodes, current driver, Tissue impedance, Transconductance Amplifier.

## 1. INTRODUCTION

A widely used method for measuring bio impedance is the tetrapolar electrode configuration. Which involves applying an ac current through one pair of electrodes and separates current electrode and voltage electrode and measures the resulting voltage potentials on a second pair of electrodes. Tissue impedance characteristics can be measured using techniques such as synchronous detection. Synchronous detection is a signal processing technique that makes possible extracting even weak signal in strong noise.

Electrical Impedance Spectroscopy (EIS), has been widely used as a noninvasive technique for measuring many passive electrical properties from biological materials such as: cancerous tissues; tumors, meningiomas and brain cellular oedema. It can also be used for analyzing body composition. Also, it is considered as fast, inexpensive practical and efficient. Microelectronics systems applied to health care solutions provide advantages of small size devices, possible wireless signal and power transmission, portability, long time implant for low power circuits, and possibility of improving the sensing of weak signal (on the order of millivolts) by taking them out in-suit.

The ac current driver must have sufficient accuracy over the total operational bandwidth and its output must be independent of load variations. As a result, the current driver requires a relatively high output impedance relative to the load and low distortion (total harmonic distortion;  $\text{thd} < 1\%$  typically) particularly for multi frequency drive currents.

EIS techniques have shown good resulting normal and cancerous skin in superficial tissues. Most EIS systems consists of applying multi frequency sinusoidal current of constant amplitude into the tissue sample, measuring the resulting potential and then calculating transfer impedance

## 2. LITERATURE SURVEY

A Variety of current drivers have been reported in the literature, mainly using discrete designs such as the Howland circuits in which a output impedance is degraded due to large common voltage at the load, Modified mirror howland current circuit that suffers from instability problems with more power consumption.

Differential current generator and Current conveyor current sources have a linearity error of 0.5% from -0.5V to 0.5V peak to peak input voltage. Operational transconductance amplifier exhibit more power consumption along with 10% of linearity error from -0.5V to 0.5V peak to peak input voltage. Hence the need for wideband operation, which is limited in existing integrated current drivers. From the above discussion it is clear that all the techniques proposed so far fail to achieve a complete optimized current driver that can effectively increase the utility of the cancer detection system.

## 3. PROPOSED ARCHITECTURE

### 3.1 Current Driver Architecture:

Here it uses two identical single input differential output current drivers (Sub drivers), one for sinking current and the other for sourcing current to establish a balanced voltage across the load ZL. Each sub driver consists of a pre-amplification stage realized by a differential difference transconductance amplifier (DDTA1 or DDTA2) followed by a transconductance (GM1 or GM2), which performs the

voltage to current conversion operation and drives the load. An on-chip sense resistor ( $R_{s1}$  or  $R_{s2}$ ) is used to monitor the output current  $I_L$  of each subdriver, and the voltage across the resistor is fed back via a pair of voltage buffers [  $(B_1, B_2)$  or  $(B_3, B_4)$  ] to the appropriate terminals of the respective DDTA, thus forming a negative-feedback loop. The control voltage  $V_{ref}$  applied to transconductors serves to accurately set the dc voltages levels.

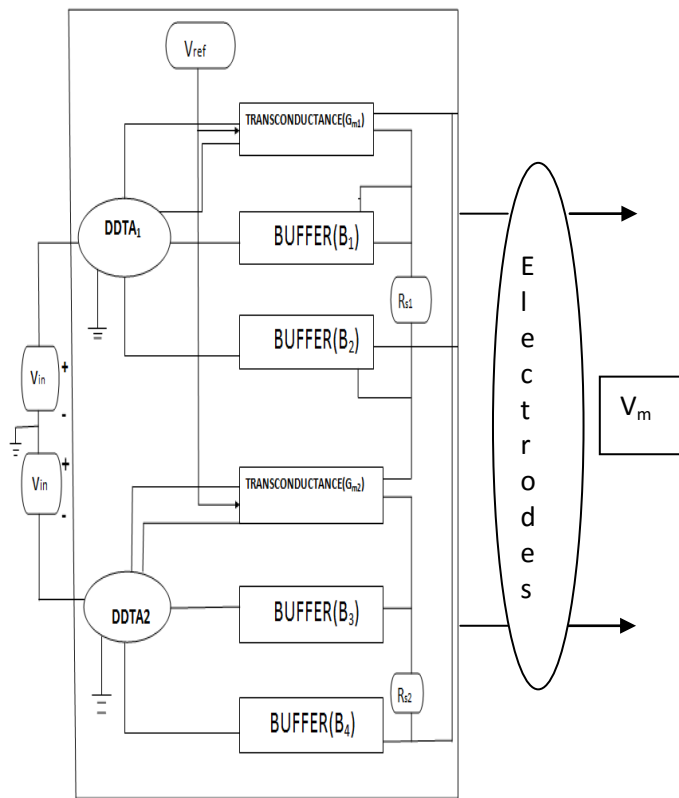

Fig-1: Architecture of Current Driver

### 3.1.1.DDTA:

DDTA is a Differential Difference transconductance amplifier. DDTA transistor –level schematic uses a differential topology. From the figure the transistors  $Q_e, Q_f, Q_g, Q_q, Q_p, Q_i, Q_h, Q_0$  form two differential pairs (input transconductance stage whose output currents are summed at the drain of the diode- connected transistors  $Q_b$  and  $Q_d$ ). Transistors  $Q_f$  and  $Q_g$  provide source degeneration to enhance the input common-mode range. In this circuit we use current mirror transistors. The current mirror is a circuit which are widely used in integrated circuit technology. The current mirror is used to provide bias currents and active loads to circuits. In the circuit current mirror comprising transistor pairs  $Q_a, Q_b$  and  $Q_c, Q_d$  from a differential output stage with transistors  $Q_k$  and  $Q_t$ . This topology allows for independent control of the output stage of the circuit without affecting the input transconductance stage. Transistors  $Q_s$  and  $Q_u$  provide common mode feedback control operated in triode region.

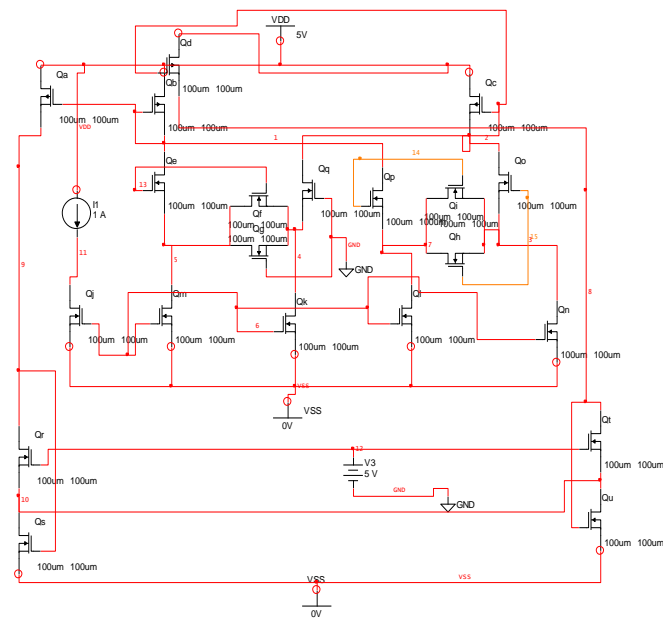

Fig-2 : DDTA Transistor – level schematic

### 3.1.2. Transconductance:

An Amplifier that produces output current from differential input voltage is called OTA. Hence Operational transconductance amplifier is voltage controlled current source. In the figure the circuit schematic of the transconductance that uses a three current mirror operational transconductance amplifier topology. The low supply voltage specification of the design dictates the use of simple current mirrors with reduced over drive voltage operation of the output transistors

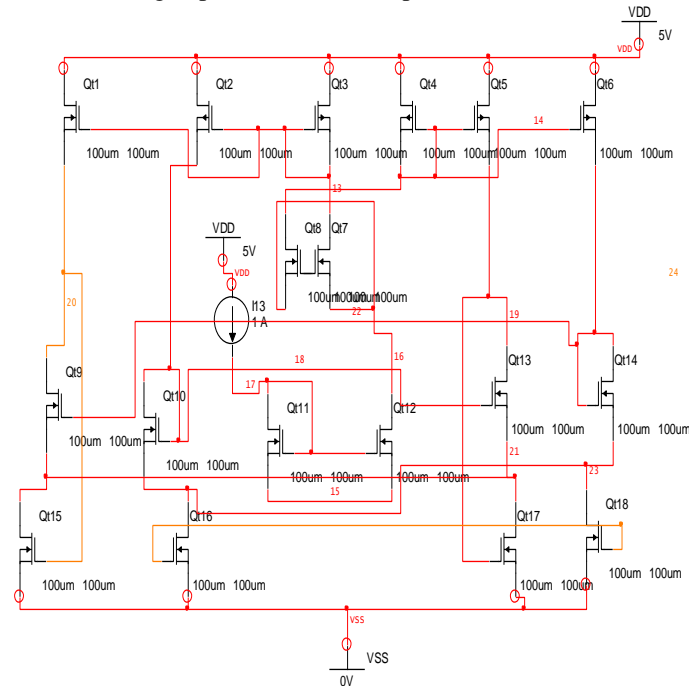
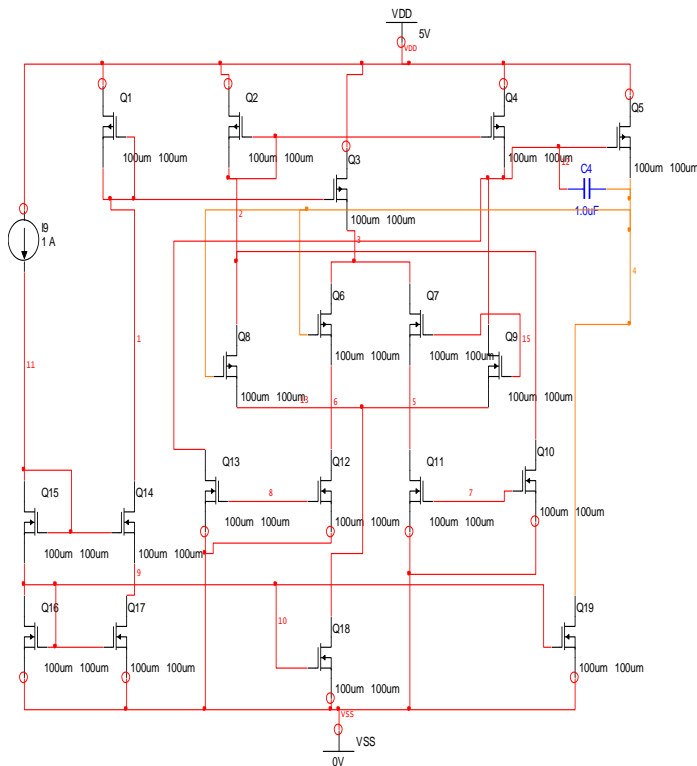

Fig-3: Transistor –level schematic of the transconductor

Here the circuit uses triode transistors Qt15 and Qt17 in order to approximate output dc-level stabilization. Thus due to the variations in the process determination of accurate output common -mode level is not possible. In order to overcome this transistors Qt16 and Qt18 are used whose gate voltages are controlled by external voltage.  $V_{ref}$  are added in the secondary n-type metal oxide semiconductor (MOS) current mirror branches. Output dc levels can be altered by adjusting  $V_{ref}$ . Thus care must be taken to ensure that  $V_{ref}$  holds Qt16 and Qt17 in the triode region. The transistors Qt10 and Qt13 forms the current mirror pairs. Through current mirroring, the drain currents of Qt10 and Qt13. Here  $V_{DD}$  is a positive supply voltage. The OTA voltage compliance was designed to be 2V by ensuring low saturation -voltage operation of the output transistors

**3.1.3. Voltage Buffer:**

A circuit which Transfers of voltage from a high output impedance circuit to a low input impedance circuit is a voltage buffer. A circuit that transforms electrical impedance from one circuit to another circuit is called buffer amplifier. Succeeding circuit prevents loading of a preceding circuit is accomplished by buffer amplifier. For example, a sensor may have the capability to produce a voltage or current corresponding to a particular physical quantity. The voltage buffer connected between these two circuits prevents the load input impedance current.

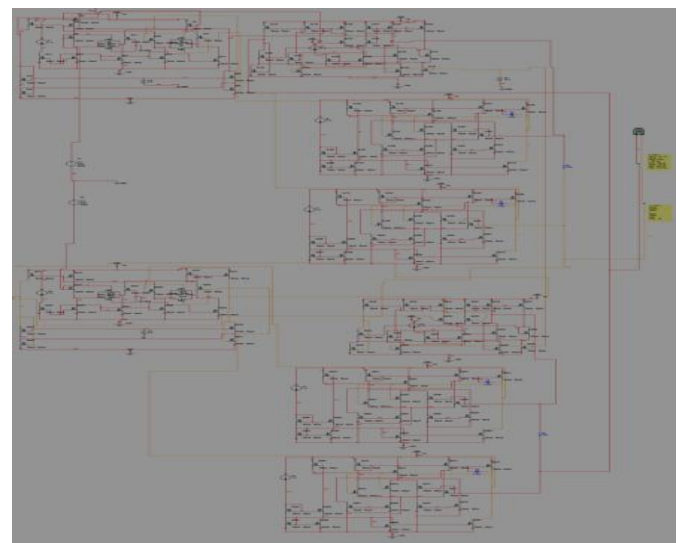

**Fig-4:** Transistor- level schematic of the voltage buffer

This is the circuit schematic of voltage buffer. The transistors Q6 to Q9 forms two complementary input

differential input pairs for enhanced input common mode range , where as the current mirror pairs Q10 –Q11 and Q12- Q13 sense the P- type MOS differential pair currents. Current mirror pairs Q3 and Q4 performs the differential to single-ended operation , Where as Q5 and Q19 form a second stage gain for enhanced operation loop gain. Capacitor C4 ensures a sufficient phase margin when output is fed back to a negative input terminal for unity gain operation.

**5. SIMULATION RESULTS**



**Fig-5:** Layout of current driver

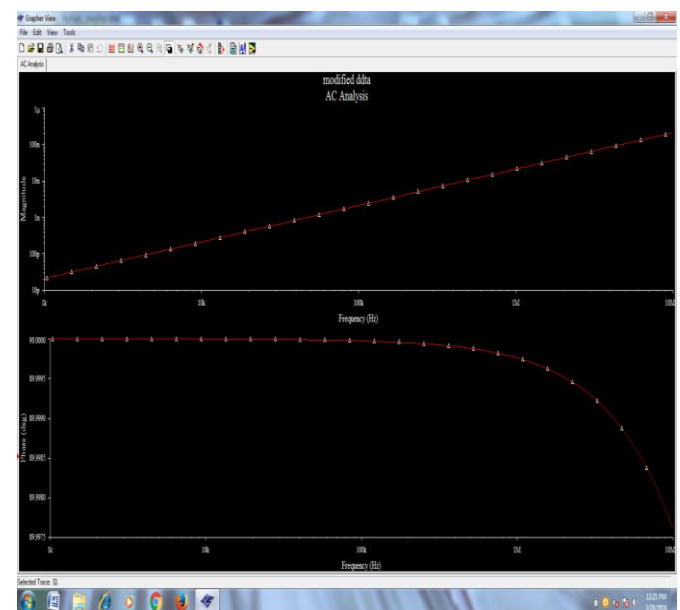

**Fig-6:** AC Analysis of current driver

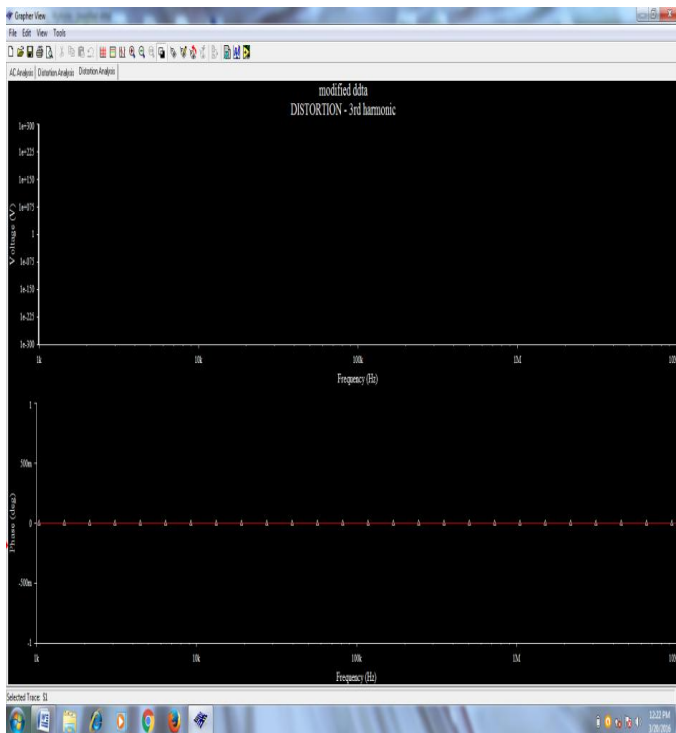

Fig-7: Frequency vs phase with zero distortion

PARAMETERS	Current Conveyor	Differential Current Generator	Differential OTA	Negative feedback
Maximum output current	>1m Ap-p	350µA p-p	500µA p-p	888µAp-p
Band width	10KHz - 250KHz	90KHz	10KHz-1MHz	1KHz - 10MHz
Total Harmonic Distortion	2%	1%	0.1%	0%
Supply Voltage	5V	5V	5V	3.46 V

Table-1: Measured Results

### 3. CONCLUSION & FUTURE SCOPE

A Wideband integrated current driver has been presented. It uses negative feedback to accurately set the output current amplitude into the load and achieve low and zero distortion. The circuit is intended for active electrode realization capable of being mounted on clinical tools for real time Bio-medical applications. The output current and impedance of the circuits were investigated over the 1 KHz to 10MHz. Thus the proposed work is to implement a current driver circuit which exhibits stabilized response over broad band frequencies .It enhances performance by reducing total harmonic distortion. Thus it is clear that an optimized current driver circuit is implemented. This circuit can still be modified for broadband frequencies.

### REFERENCES

- [1] R. Bayford and A. Tizzard, "Bioimpedance imaging: An overview of potential clinical applications," *Analyst*, vol. 137, no. 20, pp. 4635–4643, Oct. 2012.
- [2] R. J. Halter, A. Hartov, J. A. Heaney, K. D. Paulsen, and A. R. Schned, "Electrical impedance spectroscopy of the human prostate," *IEEE Trans. Biomed. Eng.*, vol. 54, no. 7, pp. 1321–1327, Jul. 2007.
- [3] S. Abdul, B. H. Brown, P. Milnes, and J. A. Tidy, "The use of electrical impedance spectroscopy in the detection of cervical intraepithelial neoplasia," *Int. J. Gynecol. Cancer*, vol. 16, no. 5, pp. 1823–1832, Sep./Oct. 2006.
- [4] R. Pallás-Areny and J. G. Webster, *Analog Signal Processing*. New York, NY, USA: Wiley, 1999.
- [5] A. S. Tucker, R. M. Fox, and R. J. Sadleir, "Biocompatible, high precision, wideband, improved Howland current source with lead-lag compensation," *IEEE Trans. Biomed. Circuits Syst.*, vol. 7, no. 1, pp. 63–70, Feb. 2013.
- [6] Y. Mohomadouet *et al.*, "Performance evaluation of wideband bioimpedance spectroscopy using constant voltage source and constant current source," *Meas. Sci. Technol.*, vol. 23, no. 10, Oct. 2012, Art. ID. 105703.
- [7] R. J. Halter, A. Hartov, and K. D. Paulsen, "A broadband high-frequency electrical impedance tomography system for breast imaging," *IEEE Trans. Biomed. Eng.*, vol. 55, no. 2, pp. 650–659, Feb. 2008.
- [8] L. Yan *et al.*, "A 3.9 mW 25-electrode reconfigured sensor for wearable cardiac monitoring system," *IEEE J. Solid State Circuits*, vol. 46, no. 1, pp. 353–364, Jan. 2011.
- [9] S. Hooet *et al.*, "A 4.9 mΩ-sensitivity mobile electrical impedance tomography IC for early breast-cancer detection system," in *Proc. IEEE ISSCC Dig. Tech. Papers*, San Francisco, CA, USA, 2014, pp. 316–317.
- [10] H. Hong, M. Rahal, A. Demosthenous, and R. H. Bayford, "Comparison of a new integrated current source with the modified Howland circuit for EIT applications," *Physiol. Meas.*, vol. 30, no. 10, pp. 999–1007, Oct. 2009.
- [11] L. Constantinou, I. F. Triantis, R. Bayford, and A. Demosthenous, "Highpower CMOS current driver with accurate transconductance for electrical impedance tomography," *IEEE Trans. Biomed. Circuits Syst.*, vol. 8, no. 4, pp. 575–583, Aug. 2014.
- [12] F. Krummenacher and N. Joehl, "A 4-MHz CMOS continuous-time filter with on-chip automatic tuning," *IEEE J. Solid-State Circuits*, vol. 23, no. 3, pp. 750–758, Jun. 1988.
- [13] J. Wtorek, "Relations between components of impedance cardiogram analyzed by means of finite element model and sensitivity theorem," *Ann. Biomed. Eng.*, vol. 28, no. 11, pp. 1352–1361, Nov./Dec. 2000.

**BIBLIOGRAPHIES**

**Mr.S.MD.Imran Ali** has pursued his B.Tech from SAFA College of Engg.& Tech, Kurnool and M.Tech from SKTMCE , Kondair. Presently he is working as Asst.Prof in Dept of ECE of Brindavan Institute of Technology & science, Kurnool.



**Mr.Shaik Naseer Ahamed** has pursued his B.Tech from SAFA College of Engg.& Tech, Kurnool and M.Tech from SKTMCE , Kondair. Presently he is working as Asst.Prof in Dept of ECE of Safa College of Engineering , Kurnool.



**Mr P.Vamshi Krishna Reddy** is pursuing his B.Tech in ECE Dept from BITS-KNL



**Mr R.Siva Prakash Reddy** is pursuing his B.Tech in ECE Dept from BITS-KNL