

Autonomous Shooting System

Chinmay Bandivdekar¹, Akshay Nivate², Gaurav Mejari³, Amit Nerurkar⁴

^{1,2,3}Vidyalankar Institute of Technology, Mumbai

⁴Professor, Dept. of Computer Engineering, Vidyalankar Institute of Technology, Maharashtra, India

Abstract - Autonomous shooting system provide protection to the area they cover and also doesn't rely on the use of humans to do so. This is what makes autonomous shooting system such an important field of research. These systems can be used not only for military purpose, but also for home defense, as well. The main goal of this system is to simulate an autonomous gun as a defense system to protect a particular area against intruders or attackers. The important qualities of an autonomous gun that make it such a valuable system are reliability, efficiency, accuracy, and intelligence. Reliability is important because an autonomous system will not be under constant monitoring from a human when employed, so it must be able to function properly on its own. Accuracy and efficiency are also major factors because all the targets need to be taken down accurately and efficiently before they became any threat to the system itself. Lastly, the system must be intelligent so that no one can bypass it by using a decoy or some sort of distraction and take control over the system.

Key Words: Autonomous, accuracy, efficiency, intelligence, reliability

1. INTRODUCTION

The autonomous shooting system is a camera based weapon system that uses software to detect and track a target and hardware to point to the target and a fire at it. It consists of a combination of hardware and software to point a mounted gun's aim to the target detected and tracked in the camera's view. The gun will have the ability to scan its field of view using a camera and fire automatically at moving targets. The field will be scanned and each frame will be processed by using OpenCV libraries for object detection, motion tracking and colour detection of the detected object. The user interface will show a continuous video stream for the camera. The system will recognize and detect and track a moving object, find its contours and centroid and fire the object until the object is removed.

The hardware will contain two servo motors for aiming the gun along the horizontal and vertical axis and another servo motor for trigger control. High definition camera will be used in conjunction with OpenCV to detect and track targets. When an object enters the field of view of the camera, the system detects it and begins tracking the object. The computer continuously updates the object coordinates and passes this information to the microcontroller which translates the coordinates to pulse widths for the servo motors to move the

gun such that it aims the detected object. The system then begins to fire upon the object until the object exits the field of view or when the object is no longer active.

2. LITERATURE SURVEY

Autonomous shooting system projects have been previously created and implemented in the past. The system as a whole is not a new technology. Various aspects of the system have been done previously for a variety of reasons, such as the motion tracking and a gun based system that executes incoming targets. These were the original and unique technologies that when integrated together will help in building our autonomous shooting system. The influence of these existing technologies has widened the range for the growth of different prototypes for future solutions. The previous projects failures and successes are determined by the researching them for the design of this project which will help to improve our system.

By researching on all the similar existing technologies implemented successfully in the past, the designers of this system intends to integrate several of them to make a specific design. The system will have several functions, mainly as a defence gun to guard. This system can also be further optimized depending on its use but initially it can be used for local security by businesses or home owners. It can even be used in battlefields in order to protect a military base from incoming enemies and can also have the ability to successfully detect and intercept incoming planes, helicopters, and missiles. The system's concept does have several uses and one can use it according to his needs.

3. PROPOSED SYSTEM

The system as we mentioned is majorly divided into hardware and software. The hardware part consist of a microcontroller and the servo motors for moving the motor attached gun along x and y axis and one for pulling the trigger. This servo motors are controlled by the microcontroller ATmega328P. The microcontroller receives the signals in the form of objects and their current position in its field of view. The microcontroller then moves the servos to the specified location by sending pulse width modulation signals. Once the gun is positioned by the servo motors, the microcontroller instructs the third motor for pulling the trigger of the gun on the object until it's neutralized.

The software part consists of four subsystems viz. Object detection, motion tracking, color detection and turret control.

1) Object detection

For detecting objects we are using the Histogram of Oriented Gradients (HOG) descriptor. This method suggested by Dalal and Triggs in their seminal 2005 paper, Histogram of Oriented Gradients for Human Detection demonstrated that the HOG image descriptor and a Linear Support Vector Machine (SVM) could be used to train highly accurate object classifiers — or in their particular study, human detectors. Thus we are using this descriptor to detect human objects in the video stream.

2) Motion tracking

Once the objects within the image have been detected, the next logical step is to track those objects. Our algorithm uses the most popular method of tracking by optical flow. The algorithm is known as the Lucas-Kanade algorithm, which is a differential method. In this method, we give some points to track and we receive the optical flow vectors of those points. So applying Lucas-Kanade there, we get optical flow of the detected object.

3) Color detection

By detecting various colors, the system will be able to differentiate between allied targets and enemy targets. For detecting colors we are using HSV instead of RGB. The primary benefit of a pixel represented by HSV is that it would be relatively easy to detect the various shades of a single color. This method gives you a nice binary image that displays the specified color as white with all other objects and colors on the screen as black. By specifying a certain range of color to represent an allied target, the system will be able to calculate the average color of the target and determine if it is a threat or not.

4) Turret control

The turret control will be the main class of the software. It will control the firing, target selection and determine the angles needed for the servo motors. The fire function will take the given target attack that target.

4. ARCHITECTURE

1) Hardware Block Diagram

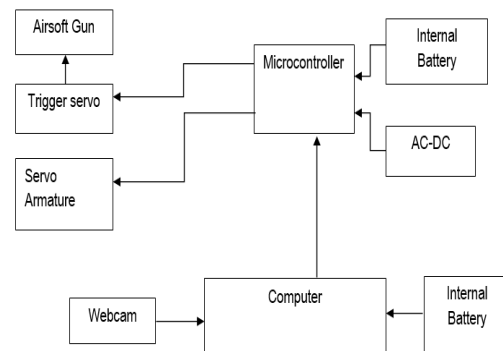

Fig -1: Hardware Block Diagram

1) Software Block Diagram

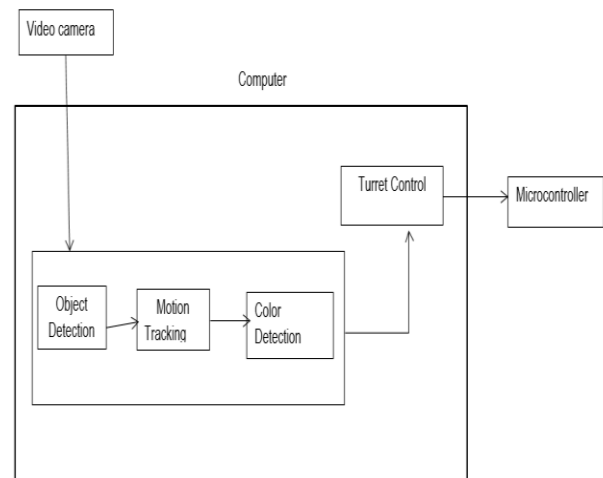

Fig -2: Software Block Diagram

5. CONCLUSION

This paper has discussed the design of autonomous shooting system. The system will focus on finding a target in its vision and then firing at it. This system will make use of the OpenCV libraries for finding and tracking a target and a mounted gun controlled by servos for firing. The performance of the proposed system may be further improved by automatic guns, night vision camera and faster servos. As for the future we plan to conduct experiments with other object detection and motion tracking approaches available for faster image processing.

REFERENCES

- [1] Navneet Dalal and Bill Triggs, "Histograms of Oriented Gradients for Human Detection." Available: <https://lear.inrialpes.fr/people/triggs/pubs/Dalal-cvpr05.pdf>.
- [2] Bruce D. Lucas and Takeo Kanade, "An Iterative Image Registration Technique with an Application to Stereo Vision." Available: <http://www-cse.ucsd.edu/classes/sp02/cse252/lucaskanade81.pdf>
- [3] The Sentry Project. Web. 03 Dec. 2011. Available: <http://www.paintballsentry.com>
- [4] Autonomous Targeting System. Available: <http://www.eecs.ucf.edu/seniordesign/fa2011sp2012/g12/>
- [5] Self-Targeting Automated Turret System. Available: <http://www.eecs.ucf.edu/seniordesign/sp2014su2014/g08/home.html>