

# Braking System with Drowsiness Detection & Inner Wiper Mechanism for Accident Prevention

Sayyad B. Layak<sup>1</sup>, Shardul Raut<sup>2</sup>, Suraj Patil<sup>3</sup>, Aniket Kumbhar<sup>4</sup>, Rohit Shinde<sup>5</sup>

<sup>1</sup>Head of Department of Mechanical Engineering, Theem College of Engineering, Maharashtra, India

<sup>2345</sup>Students of Mechanical Engineering, Theem College Of Engineering, Maharashtra, India

**ABSTRACT:** *The need of creating this project is that, nowadays mostly while travelling at night there may be an accident due drowsiness. For this purpose the system eye blink detector has been introduced to minimize such accident case. Mainly it also consist of start and stop push buttons, so that to stop the system the driver may any time press the button to stop the system while by pressing start button the system will detect if the drowsiness is detected. Eventually we are also working on the system of braking which will gradually reduce the speed of vehicle thereby raising the signals such as alarm, vibrating the steering etc. also showing the back lights in order to avoid the hitting of back vehicle.*

*Similarly, in inner wiper mechanism, the wiper will clean the windscreen from inner side. In winter season*

*or during heavy rainfall, the driver is sometimes enable to see the road clearly due to moisture that catches from inner side of glass. So we are working on the mechanism which will wipe the inner glass windscreen simultaneously along with outer wiper without distracting driver's vision.*

**KEYWORDS:** Micro Controller, Relay, Braking, Eye blink sensor, start and stop push buttons, retracting spring.

## INTRODUCTION:

Nowadays the accidents are increasing day by day, mostly during nights. In many cases the major accidents are due to the drowsiness detection of a driver in light vehicles such as cars, tempos, auto rickshaws, tourist cars etc. and heavy vehicles like truck, buses and etc.

which travels at late night from one place to another. Due to drowsiness detection the driver may have an accident or with driver drowsiness detection the light or heavy vehicle may crashed with the rural local persons walking on route and can lost one's life. This may be problematic to person walking on streets and more to the drivers. To

avoid such things the project 'Accident Prevention Using Eye Blink Detection With Braking System And Inner Wiper Mechanism' has been introduced which may not completely minimized the accidents but will minimize up to some extents. The project is such that it contains a small circuit containing 12v supply from battery converting into 5v as all system has voltage of 5v. this circuit is attached to the sensor unit which will be placed side of an eyes through goggles. If eye blink is detected than it will be activated and will give command to the microcontroller than this microcontroller will control all the circuit. At a time the buzzer will on and steering will vibrate and speed of vehicle will reduce gradually.

Purpose behind inner wiper mechanism is also same as that of accident. In winter season and heavy rainfall the vehicle from inside the glass of windscreen catches the moisture which seems not so important but sometimes or even many times may lead to the major accident. At such moment some drivers stop the vehicle and wipe out the glass which is time consuming or some drivers wipe the glass while driving the vehicle which may leads to accident by distracting driver's concentration. This mostly happens in heavy vehicles since it has no air cooler inside which may drag the moisture. So this is the cheapest method in non ac vehicles rather than installing some other techniques.

**BACKGROUND STUDY:**

Previously the very first method of eye blink detection was made through image processing. But sometimes it contains slow processing of image and leads to more time. It needs additional set of computer or laptop which becomes complicated arrangement. Sometimes the shocks in the vehicle due to bad conditions of the road may damage the program stored in laptop or computer. So the second technique installing sensors side of eye or in long range is the possible way to detect the accurate blinking of eyes without distracting the driver's concentration.

As in wiper, the previously and even now has only a set of wiper from outside. So it is not possible to clean the moisture from inside. The driver has to wipe out the foggy glass which may results in accident. For that purpose inner wiper mechanism is the possible technique to clean the moisture which will move along with the outer wiper. And even if it is not necessary to move the inner wiper, it contains one notch which by pulling the only one outer wiper will be active. Again after pressing the notch the both wiper will move simultaneously.

**EYE BLINK DETECTION:**

In this eye blink detection the sensor used is used to see the blinking of eyes if a person driving the car. This will not recognize the normal flashing of eyes but will provide the time period for it, so that it will detect after the given time period. The normal flashing of our eyes is round about 3 seconds but still there are some people who flash their eyes after 5 to 7 seconds. So according to the algorithm it will detect the eye blinking not after 7seconds or if whether the eyes are closed it will be detected by transmitting IR rays and receiving the same.

**BRAKING MECHANISM:**

This mechanism consists of brake lining, tires, partially cut shaft, elliptical disc, motor and a retracting spring.

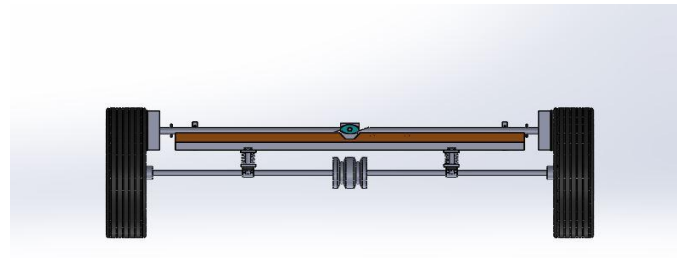

Fig 1.1. Brake Mechanism [Engaged Position]

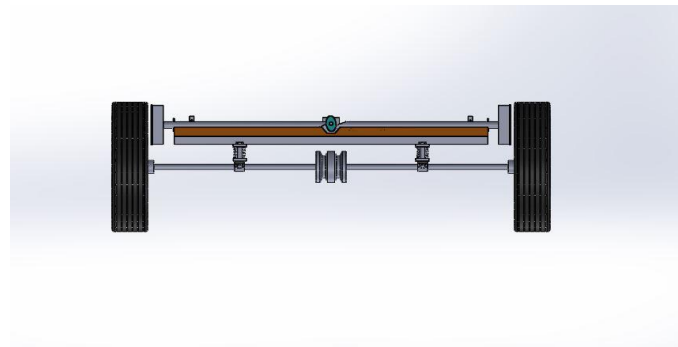

Fig 1.2. Brake Mechanism [Dwell Position]

The shafts are cut in two pieces with a taper section from both the starting section. One shaft consists of taper from top side while another from bottom side.

**ACTUAL BRAKING MECHANISM:**



Fig.1.3. Actual Braking Mechanism

This shaft have will have two motion upward-downward and sideways motions. In order to get sideways motion the upward motion is restricted by providing guides. So sideways motion can be obtained. As the elliptical gear rotates the shafts will expand and brakes will be applied. To easy sliding the shafts motion, the shaft is mounted on roller placed on hard

wood plate. Through retracting spring mechanism the shafts will back to its initial position. This process will be continued till the timing provided in the algorithm.

**INNER WIPER MECHANISM:**

The mechanism is simple but very useful in today as well as future generation. There is one flywheel fixed to a wiper motor. Connecting rod is used to convert its rotary motion into reciprocating motion. And at the end two key shaped materials will be fixed on a bolt, one from inside the glass and other from outside. So as the motor rotates the both wipers will rotate simultaneously as mounted on the same bolt. The wiper will be placed in one line to avoid the distraction of driver.

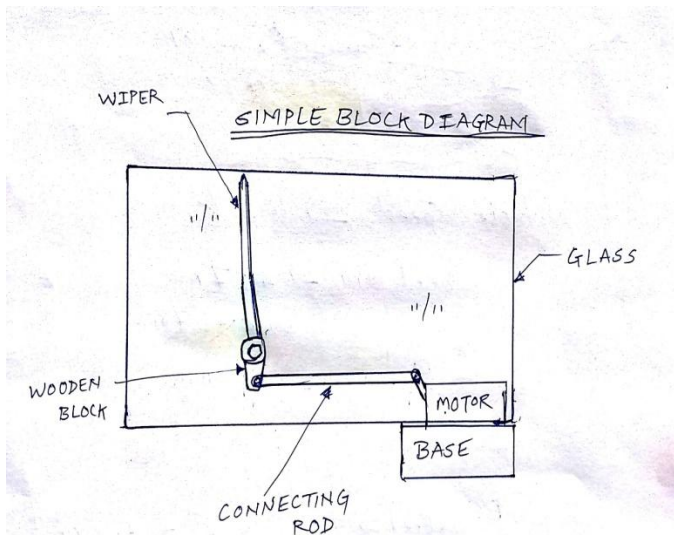

Fig 2.1. Inner Wiper Mechanism

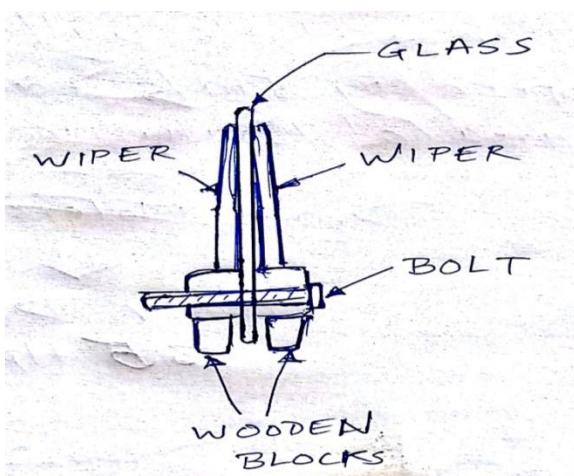

Fig 2.2. Inner Wiper Mechanism [Side View]

This mechanism is important because just to auto clean the moisture catch from inside the windscreen. By which the driver can drive the vehicle with more concentration in heavy rainfall and even in winter season.

**METHODOLOGY:**

The system works when the driver is in drowsy state. The sensors are attached to the goggles by side ways. Due to this drivers vision is not been distracted. There is adjustable screw to control the range of sensor as well to control the timer of eye blink. The time set for blink is of 3 seconds. If the driver remained closed his eyes for 3 seconds than the eye blink will be detected and this circuit will give signal to the microcontroller. Microcontroller will control the whole circuit and will give signal to relays.

The three relays are placed in series.

- The vibrator and buzzer consist of one relay.
- The drive motor.
- The braking motor.

As the vibrator and buzzer will ON the drive motor will be disconnected and at a same time the braking motor will be activated which after rotating the shafts will expand outwards and inwards due to elliptical gear and taper provided to shafts.



Fig 3.1 Brake Guides

And the speed of vehicle will be gradually decrease thereby showing back lights to avoid crash of the vehicle coming from back.



Fig 3.2 Tapers [For Braking]

**WORKING OF THE CIRCUIT OF THE SYSTEM:**

There are many circuits present in this system; all the circuits are interconnected with each other. The circuits are:-

- Microcontroller Circuit
- Relay Circuit
- Driver Circuit
- Timer Circuit
- Alarm Circuit
- Braking Mechanism
- Inner Wiper Mechanism

**DESIGN OF EYEBLINK SENSORS:**

The eye blink sensor consist of an Infrared Transmitter and a receiver. The infrared transmitter transmits the rays and the receiver receives the rays. The sensors sense our reaction of the eye and gives information to the system that is the timer circuit. The timer circuit then proceeds the information to the microcontroller and all the processing are done.

**MANUFACTURING AND ASSEMBLY**

**PROCESS OF THE SYSTEM:**

**THE PCB BOARD:**

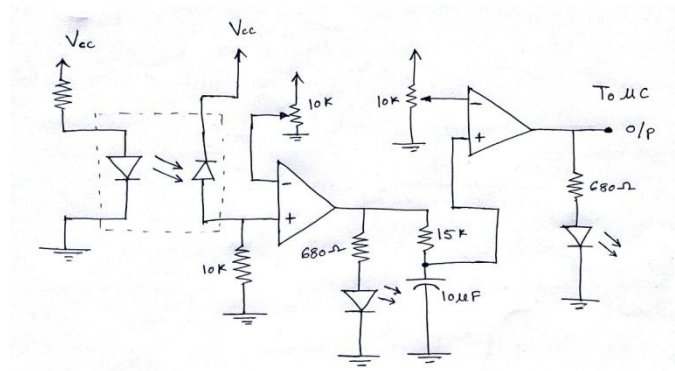

Fig 4. Eyeblink Circuit

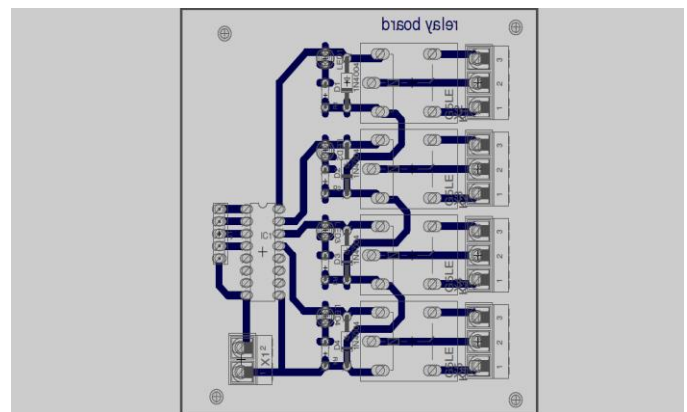

Fig 5. PCB Manufacturing

The PCB board is design according to the requirements of the project. This is the design structure of PCB. According to this the components are soldered. The board is mounted with screw and drilled.

**MICROCONTROLLER:**

**BLOCK DIAGRAM:**

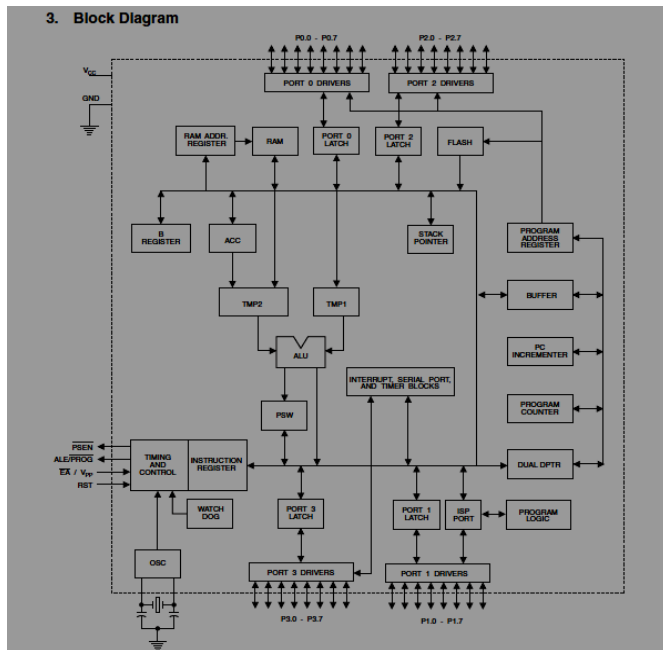

Fig 6.1 Block Diagram [Microcontroller]

**DESCRIPTION FOR SELECTION:**



Fig 6.2. Microcontroller

The microcontroller consists of 4 ports each having 8 input and output lines providing of 32 I/O lines. This ports can be used for output data and to read a state of sensor, or a switch. This microcontroller is a low power, high performance CMOS 8-bit microcontroller with 8K bytes of in-system programmable Flash memory. The

idle mode stops the CPU while allowing the ram, timer, serial port and interrupt system to continue functioning.

**RELAY UNIT:**

This is the relay unit mounted on PCB board, there are three relays soldered on board. One relay is for vibrator and buzzer another two for braking and car drive purpose.

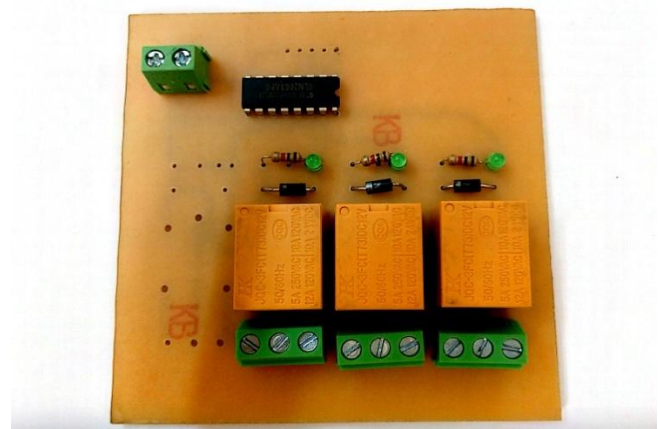

Fig 7. Relay

The capacity of this relays is 1200v. Out of this three relays when the eye blink is detected the two relays activates the buzzer, vibrator and braking while third relay deactivates the drive motor.



Fig 8. Current Converter

This is the circuit which converts 12v supply of battery into 5v as all the components i.e. buzzer and vibrator are of 5v.

**BUZZER:**

The alarm indicates the driver by giving an alarm sound and the driver gets alert about the sleeping temptations.



Fig 9. Buzzer

**Power required to drive motor:-**

$$P = I \times V$$

Where,

I= current

V= voltage

$$P = 6.5 \times 180$$

$$P = 1170W$$

**ISOMETRIC VIEW:-**

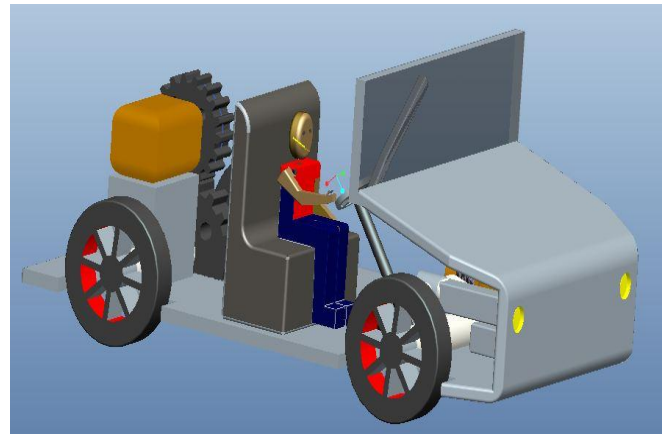

Fig 11. Car [3D Model]

**VIBRATOR:**

This is the vibrator kept in the circuit of the system. In real time the vibrator is set under the seat of the driver or at the back of the seat of the driver. The vibrator has a separate driver circuit and a relay for its control. The vibration is controlled by the microcontroller. A vibrator is fixed in the circuit in which it will vibrate and make the driver alert about the drowsiness condition.

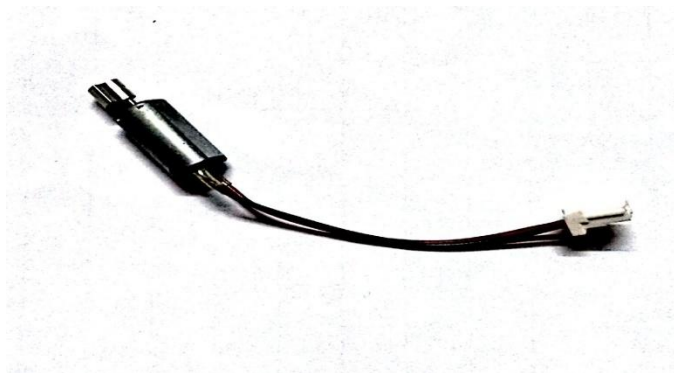

Fig 10. Vibrator

**SPECIFICATION OF THE MOTOR:**

- DRIVING SPEED = 4000 RPM
- VOLTAGE = 180 VOLT DC, 6.5 AMPS
- INPUT = 3.5 HP

**FUTURE SCOPE:**

According to the point of future generation the drowsiness detection and inner wiper mechanism is the most important mechanism to avoid the accident caused in day to day life. So the installation of this inner wiper mechanism and braking system in each and every vehicle is necessary. By installing a sensor sideways of the eyes the sensor will detect the drowsiness of the driver which will sense and accordingly the microcontroller will operate the entire circuit. As braking is applied and the main driving motor will be disconnected. This will minimize the percentage of accidents in the future. An inner wiper is another method which will be placed from inside the windscreen. As the lever is put on the inner wiper will rotate accordingly with the outer wiper by cleaning the moisture present from inside the windscreen. This mechanism will be helpful in the future to minimize the accident to some extent.

**CONCLUSION:**

The components in the systems are revised and checked for the proper working of the system and all the components are working. The torque of the motor is calculated. The Electronic parts are checked. The time taken for the break, buzzer and the vibrator to apply is calculated and shown in the result. The system is drawn in Pro-E. The above results and the works shows the present design is best and the Accident alarm indicator and breaking is working good according to the eye blink closing and opening of the driver and it is successful.

[9] W.W Weirwille, "Overview Of Research On Driver Drowsiness Definition And Driver Drowsiness Detection," 14<sup>th</sup> International Technical Conference On Enhanced Safety Of Vehicles, pp23-26,1994

**REFERENCE:**

[1] Davies, E.R. "Machine Vision: theory, algorithms, and practicalities", Academic Press: San Diego, 1997.

[2] Eriksson, M and Papanikolopoulos, N.P. "Eyetracking fr Detection of Driver.

[3] Fatigue", IEEE Intelligent Transport System Proceedings (1997), pp 314-319.

[4] Accident prevention using eye blink and head movement Abhi.R.Varma, Seema.V.Arrote, ChetnaBharti..\..\paper4.pdf

[5] Stephen H. Impairment of driving performance caused by sleep deprivation or alcohol. A comparative study. Human Factors, 1999, 41(1):118-128.

[6] Singh, Sarbjit and Papanikolopoulos, N.P."Monitoring Driver Fatigue Using Facial AnalysisTechniques", IEEE Intelligent Transport SystemProceedings (1999), pp314-318.

[7] Grace Retal. "A Drowsy Driver Detection Systemfor Heavy Vehicles", Digital Avionic SystemsConference, Proceedings, 17th DASC. TheAIAA/IEEE/SAE, I36/1-I36/8 (1998) vol. 2.

[8] T. Moriyama, T. Kanade, J.F. Cohn, J. Xiao, Z. Ambadar, J. Gao, and H.Imamura. Automatic recognition of eye blinking in spontaneously occurringbehavior. Proceedings of the International Conference on Pattern Recognition (ICPR 2002), Vol. IV, pages 78-81, Quebec City, Canada, 2002.