

Survey on Different Image fusion Techniques

Mamta M. Mistry¹, Brijesh Vala²

¹M.E., Computer Engg., Parul Institute of Engineering and Technology, Gujarat, India

²Assistant Professor, Computer Science and Engg. Dept, Parul Institute of Engineering and Technology, Gujarat, India

Abstract - One of the great research fields in image processing is image fusion. Image fusion is defined as the integration of information and data from all input registered images without any loss of information and distortion. It is not able to get an image with all relevant features in focus, so to get all the features in one image is by fusing images with different focus settings. This paper presents a survey of different techniques like, Discrete Wavelet Transform Method [13], Principal Component Analysis (PCA) [13], Intensity Hue Saturation [1] based method etc.

Key Words: Image fusion, PCA, DWT, IHS,FIHS,GIHS,AIHS

1.INTRODUCTION

Image fusion is the process of integrate relevant information from a set of input images into a single image, where in the resultant fused image[12] contained more complete information of the all the input images in a single image itself. The input image can be multi view, multi-modal, multi sensor or multi temporal. Multi-view fusion is called as images from the same modality and taken at the similar time [12] but from different viewpoints. Multi-modal fusion is called as images coming from different sensors. Multi-temporal fusion is called as images taken at different times. Image fusion has found many applications like in computer vision, remote sensing [10], intelligent robots and military purpose. In image processing there are several situation where high spatial and high spectral information necessary in a single image; especially in the field of remote sensing [4]. However, the devices are not capable of providing such information due to their limitation. One possible solution for this is fusion. Image fusion methods can be categorized into two as - spatial domain fusion and transform domain fusion.

2. DIFFERENT IMAGE FUSION TECHNIQUES

Image fusion techniques can improve the quality of a digital image without spoiling it. There are various method that have been developed to perform image fusion

2.1 Simple Maximum Method

In this image fusion method, the fused image is achieved by taking the minimum intensity [8] of corresponding pixels from both the input image.

$$F(i, j) = \sum_{i=0}^m \sum_{j=0}^n \max A(i, j) B(i, j) \quad (1)$$

Where, A (i,j), B(i,j) are input images,
F(i,j) is fused image.

2.2 Simple Minimum Method

In this image fusion method, the fused image is achieved by taking the minimum intensity [8] of corresponding pixels from both the input image.

$$F(i, j) = \sum_{i=0}^m \sum_{j=0}^n \min A(i, j) B(i, j) \quad (2)$$

Where, A (i,j), B(i,j) are input images
F(i,j) is fused image.

2.3 Simple Average Method

In this image fusion method the fused image is achieve by taking the average intensity [8] of corresponding pixels from both the input image.

$$F(i, j) = A(i, j) + B(i, j)/2 \quad (3)$$

Where, A (i,j), B(i,j) are input images
F(i,j) is fused image.

2.4 Weighted Average Method

In this image fusion method the fused image is achieve by taking the weighted average intensity[8] of corresponding pixels from both the input image.

$$F(i, j) = \sum_{i=0}^m \sum_{j=0}^n W A(i, j) + (1 - W)B(i, j) \quad (4)$$

Where, A(i, j), B(i,j) are input images
F(i,j) is fused image and W is weight factor.

2.5 Principle Component Analysis (PCA) Method

Image fusion process using PCA is described below:
--Read the two input images I1 (x, y) and I2 (x, y) which are to be fused.
--From the input image matrices produce the column vectors [13].
--Find the covariance matrix of two column vectors.

--Find the Eigen values and Eigen vectors of the covariance matrix.
 --The column vector corresponding to the larger Eigen value is normalized by dividing each element with mean of Eigen vector.

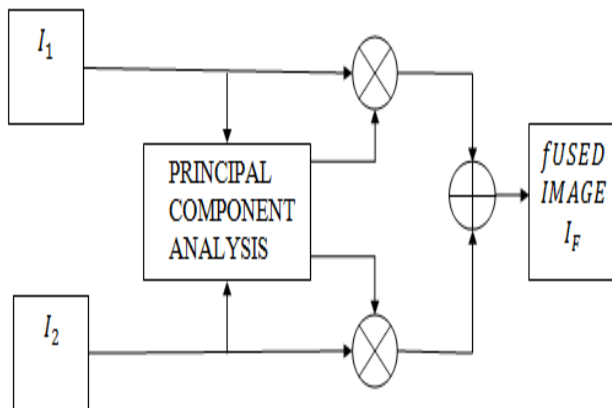

Fig.1: Flow diagram of PCA based Image fusion[13]

--Normalize the column vector corresponding to the larger Eigen value by dividing each element with mean of the Eigen vector.
 --The values of the normalized Eigen vector act as the weight values which are respectively multiplied with each pixel of the input images.
 --Sum of the two scaled matrices will be the fused image matrix.
 --Normalized Eigen vector value act as the weight [13] values which are multiplied with each pixel of the input images.
 --The resulting fused image matrix will be sum of the two scaled matrices.

2.6 Discrete Wavelet Transform (DWT) Method

The DWT decomposition uses a cascade of special low-pass and high-pass filters and a sub-sampling operation [8]. The outputs from 2D-DWT are four images. Those four images have size equal to half the size of the original image. So from first input image we will achieve HHa, HLa, LHa, LLa images and from second input image we will achieve HHb, HLb, LHb, LLb images [8].

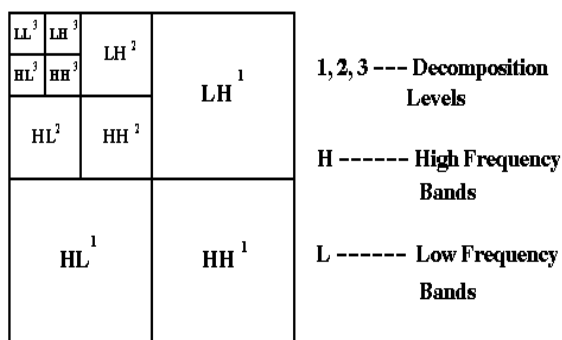

Fig 2: Wavelet decomposition[8]

LH means that low-pass filter is applied along x coefficient [13] and followed by high pass filter along y coefficient. The LL image contains the approximation coefficients. LH image contains the horizontal detail coefficients. HL image contains the vertical detail coefficients; HH contains the diagonal detail coefficients. The wavelet transform can be performed for multiple levels.

The next level of decomposition is performed using only the LL image. The result is four sub-images each of size equal to half the LL image size

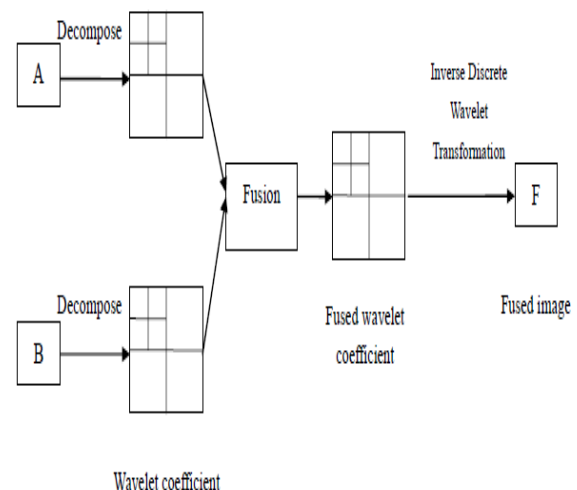

Fig. 3: Wavelet Based image fusion[8]

--Read the two input images.
 --Perform DWT on both images A and B.
 --Perform level 2 DWT on both images A and B
 --Let take the DWT coefficient of image A will be [HHa HLa LHa LLa].
 --Let take the DWT coefficient of image B will be [HHb HLb LHb LLb]
 --Calculate the average of pixels of the two band from HHa and HHb and store to HHn. b and store to LLn.
 -- Calculate the average of pixels of the two band from HLa and HLb and store to HLn.
 -- Calculate the average of pixels of the two band from LHa and LHb and store to LHn.
 -- Calculate the average of pixels of the two band from LLa and LL
 --Now we have new HHn, HLn, LHn, LLn DWT coefficients.
 --Perform Inverse DWT on the HHn, HLn, LHn, LLn coefficients.
 --Obtain the fused image and display.

2.7 Intensity Hue Saturation (IHS) Method

The IHS is a color model that is widely used to describe colors perceived by human being. For converting RGB color model to IHS color model several mathematical representations are presented. In this IHS model, the Intensity (I) component contain the spatial information of the image, while the Hue (H) and the Saturation (S)

components contain the color information of the image[1]. The transformation from RGB color model to IHS color model is shown in Fig.4

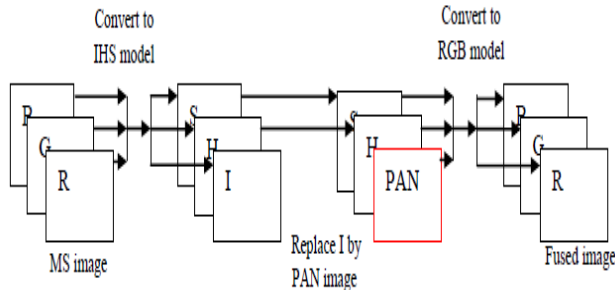

Fig.4: IHS fusion technique[1]

The intensity value is taken as the maximum value of Red, Green and Blue values ($I=1/3(R+G+B)$). The basic idea is as follow:

- First the MS image composite is changed from the RGB color space to the IHS color space domain.
- The intensity element which is the spatial component is replaced.
- At the same time the hue and saturation component are resampled to the resolution of panchromatic image .
- At last inverse IHS transformation is used to get back into RGB color domain to obtain fused image

2.8GIHS Method

The generalized IHS fusion method introduced where the fourth component added with the process of IHS transforms. The Intensity (I) value of the fourth component has more. The low intensity (I_0) is replaced by high resolution (I_{new}) [6] of Gray level image and after that transformed back to original RGB with H (Hue) and S (Saturation) components which are original.

2.9FIHS Method

This method provide fast computing capability for fusing images, this method can extend the traditional three-order transformations to an arbitrary order[13]. It can also quickly merge massive volumes of data with different resolutions by requiring only the resample MS data, i.e., it is well suitable in terms of processing speed for merging IKONOS images. But, FIHS fusion also distorts color [9] in the same way as the traditional IHS fusion technique. IHS fusion with spectral adjustment can be represented as [14],

$$\begin{matrix} R' & R & + & \delta \\ G' & G & + & \delta \\ B' & B & + & \delta \end{matrix} \quad (5)$$

Where, $\delta = PAN - I$

Where, $I=(R+G+B) /3$

2.9AIHS Method

IHS based method introduce new modifacatin that improve the spectral quality of the image[11]. First, in this method image adaptive coefficients are added for IHS to obtain more accurate spectral resolution[11]. Second, an edge-adaptive was adding IHS method to enforce spectral fidelity away from the edges. The integration of edge-adaptive method and image-adaptive coefficient method, are call as adaptive IHS. The adaptive IHS method produces images with higher spectral resolution which maintaining the high-quality spatial resolution of the original IHS [11].

3. COMPARATIVE STUDY OF VARIOUS IMAGE FUSION TECHNIQUES

Table -1 Comparative Study Of Various Image Fusion Techniques

Sr. No.	Methods	Advantage s	Limitation
1	Simple Maximum	Fused image is highly focused image[8]	Pixel level method are affected by blurring effect which directly affect on the contrast of the image [8]
2	Simple Average	Simple in implementation [8]	Resultant fused image is not clear [8]
3	PCA	PCA is a process which transforms number of correlated variable into number of uncorrelated variables [8], this property can be used in image fusion.	Spectral degradation is present[8]
4	DWT	It provides better signal to noise ratio than pixel based approach[8]	less spatial resolution [8]

5	IHS	Better Spectral quality in green vegetation areas[4], Better visual effect with high spatial quality and spectral quality similar to natural color	Not good for non vegetation areas, It is only suitable for exactly Three band of MS image[4]
6	GIHS	It is suitable for four band of MS image, provides a satisfactory result both visually and quantitatively.	Color distortion
7	FIHS	High quality image, High processing speed[4]	Not used in vegetation[4]
8	AIHS	The major advantage of this method is it is insensitivity to mis-registration and aliasing [11]	Still spectral distortion is present

3. CONCLUSIONS

This paper provides a review of different image fusion techniques. Based on the analysis done on various transform domain techniques such as, Discrete Wavelet Transform (DWT), Principle component Analysis (PCA) and Intensity Hue Saturation (IHS) techniques. It has been concluded that each technique it meant for specific application and one technique has an edge over the other in terms of particular application.

REFERENCES

[1] Amira Nabi11, Zaki Nossair, Adel El-Hennawy."Filterbank-Enhanced Ihs Transform Method For Satellite Image Fusion" IEEE April 16-18, 2013, National Telecommunication Institute, Egypt

[2] Aparna Vijayan, Sreeram.S "Survey On Image Fusion Techniques" International Journal of Engineering Research and General Science Volume 3, Issue 3, May-June, 2015 ISSN 2091-2730

[3] Dong Jiang, Dafang Zhuang and Yaohuan Huang "Investigation of Image Fusion for Remote Sensing Application"-INTEC 2013

[4] Donamol Joseph, T.Jemima Jebaseeli "A Survey Of Fusion Of Remote Sensing Images To Avoid Spectral Distortion" International Journal of Engineering Research & Technology (IJERT) Vol. 1 Issue 8, October – 2012 ISSN: 2278-0181

[5] Hamsalekha.R, Dr.Rehna V.J" Analysis of Fusion Techniques with Application to Biomedical Images: A Review" International Journal of Emerging Engineering research and technology volume 3,Issue 1,January 2015

[6] Ihs And Gihs Techniques On Satellie Image Fusion

[7] Irfan Kosesoy, Mufit Cetin, Abdulkadir Tepecik "A Toolbox for Teaching Image Fusion in Matlab"ELSEVIER 7th World Conference on Educational Sciences, (WCES-2015), 05-07 February 2015, Novotel Athens Convention Center, Athens, Greece

[8] Kusum Rani, Reecha Sharma " Study of Different Image fusion Algorithm" International Journal of Emerging Technology and Advanced Engineering Website: www.ijetae.com ISSN 2250-2459, ISO 9001:2008 Certified Journal, Volume 3, Issue 5, May 2013

[9] Miloud Chikr El-Mezouar, Nasreddine Taleb, Kidiyo Kpalma, and Joseph Ronsin"An IHS-Based Fusion for Color Distortion Reduction and Vegetation Enhancement in IKONOS Imagery" IEEE Transactions On Geoscience And Remote Sensing, Vol. 49, No. 5, MAY 2011

[10] S.A.Panwar, Sayali Malwadkar "A Review:Image Fusion Techniques for Multisensor Images" IJAREEIE ,Vol. 4, Issue 1, January 2015

[11] Sheida Rahmani, Melissa Strait, Daria Merkurjev, Michael Moeller, and Todd Wittman "An Adaptive IHS Pan-Sharpning Method" IEEE GEOSCIENCE AND REMOTE SENSING LETTERS, VOL. 7, NO. 4, OCTOBER 2010

[12] Shuyuan Yang, Min Wang, Licheng Jiao "Fusion of multispectral and panchromatic images based on support value transform and adaptive principal component analysis" ELSEVIER- Information Fusion 13 (2012) 177–184

[13] Sweta K. Shah, Prof. D.U. Shah "Comparative Study of Image Fusion Techniques based on Spatial and Transform Domain" –IJIRSET Vol. 3, Issue 3, March 2014

[14] Te-Ming Tu, Ping S. Huang, Chung-Ling Hung, and Chien-Ping Chang" A Fast Intensity–Hue–Saturation Fusion Technique With Spectral Adjustment for IKONOS Imagery" IEEE GEOSCIENCE AND REMOTE SENSING LETTERS, VOL. 1, NO. 4, OCTOBER 2004 309

[15] Yadong Song, Wei Wu, Zheng Liu, Senior Member, IEEE, Xiaomin Yang, Kai Liu, Senior Member, IEEE, and Wei Lu "An Adaptive Pan sharpening Method by Using Weighted Least Squares Filter" IEEE GEOSCIENCE AND REMOTE SENSING LETTERS