

# Mathematical Modeling of Ogive Forebodies and Nose Cones

Sonia Chalia<sup>1</sup>, Manish Kumar Bharti<sup>2</sup>

<sup>1</sup>Assistant Professor, Department of Aerospace Engineering, Amity University Haryana, Haryana, India

<sup>2</sup>Assistant Professor, Department of Aerospace Engineering, Amity University Haryana, Haryana, India

**Abstract** - One of the main design factors that affect projectile of rockets, missiles and bullets is nose cone. This paper comprises of the mathematical designing of two dimensional nose cone of rockets and bullets and the calculation of its geometrical parameters. Nose cones may have many varieties of shapes, most common of which are conical, ogival, power series or hemispherical. In this study mathematical modeling of ogive nose cone had been considered. Also, analytical formulation of aerodynamic forces and moments had been derived.

**Key Words:** Nose cone, Missiles, Ogive Forebody, Axial Forces, Normal Forces, Pitching Moment

## 1. INTRODUCTION

The shape of the nose cone must be chosen for minimum drag and hence a solid of revolution is used that gives least resistance to motion. A nose cone can has many shapes which are used primarily on the missiles travelling at supersonic speeds and are generally selected on the basis of combined aerodynamic, guidance and structural considerations. Ogive nose cone has an arc which meets the body contour smoothly, thereby creating no break in line where the ogive joins the cylindrical body. In other words, the centre of rotation of the arc is in the plane of the base of the nose.

A rocket vehicle consists of a chamber or chambers in which a satellite, instruments, animals, plants, or auxiliary equipment may be carried and an outer surface built to withstand high temperatures generated by aerodynamic heating. Much of the fundamental research related to hypersonic flight was done towards creating viable nose cone designs for the atmospheric re-entry of spacecraft. In a satellite vehicle, the nose cone may become the satellite itself after separating from the final stage of the rocket or it may be used to shield the satellite until desired orbital speeds are accomplished and then separating from the satellite. On airliners, the nose cone is called a radome, protecting the weather radar from encountering the harsh aerodynamic forces.

Given the problem of the aerodynamic design of the nose cone section of any vehicle or body meant to travel through a compressible fluid medium (such as a rocket or aircraft, missile or bullet), an important problem is the determination

of the nose cone geometrical shape for optimum performance. For many applications, such a task requires the definition of a solid of revolution shape that experiences minimal resistance to rapid motion through such a fluid medium, which consists of elastic particles.

In general, there are three drag components, drag directly related to the cross-sectional of the projectile i.e. form drag, skin-friction drag due to the contact between the surfaces of the projectile (roughness) with the surrounding air particles (viscosity) and wave drag as a result of the shock wave and base drag as a result of bluntness and diameter of the base. Since the form or wave drag may be several times of that due to friction at supersonic speeds, careful selection of the nose cone shape needs attention to assure satisfactory performance of the overall system.

## 2. MATHEMATICAL MODELING

An ogive nose cone (Figure 1) is similar to a conical shape except that the planform shape is formed by an arc of a circle instead of a straight line. The ogival shape has several advantages over the conical section. It has slightly greater volume for a given base and length, a blunter nose providing structural superiority and slightly lower drag.

There are two basic types of ogival nose cone shapes: the tangent ogive and the secant ogive. In tangent ogive, the center of rotation of the arc is in the plane of the base of the nose cone. In secant ogive, the center of rotation of the arc is aft of the plane of the base of the nose cone.

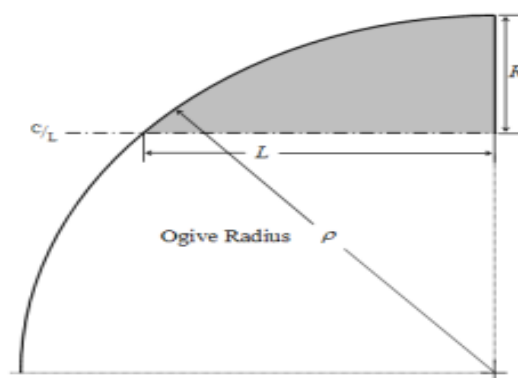

Fig -1: Tangent Ogive Nose Cone

The profile of this shape is formed by a segment of a circle such that the rocket body is tangent to the curve of the nose cone at its base; and the base is on the radius of the circle.

Here, L is the overall length of the nose cone, R is the radius of the base of the nose cone, C/L is the center line of nose cone and  $\rho$  is the curvature of arc.

Equation of Circle

$$\rho^2 = X^2 + Y^2$$

Where, X and Y are coordinates of circle.

$$\text{At } X = 0, Y = K + d/2, \rho_0 = K + (d/2)$$

Where, K is the distance between the center of the arc to Ogive curve,  $\rho_0$  is the radius of the curve at  $X = 0$ , L is cone Length and d is cone base diameter.

$$\text{At } X = L, Y = K, \rho_L = \sqrt{L^2 + K^2}$$

$$\text{Since } \rho = \rho_0 = \rho_L, K + (d/2) = \sqrt{L^2 + K^2}$$

$$\text{Hence, } K = 1/d (L^2 - d^2/4)$$

$$K = (1/d) (C^2 d^2 - d^2/4)$$

Where,  $C = L/d$  which is the caliber of the cone.

$$\text{Therefore, } K = d (C^2 - 1/4)$$

Substituting, K back into the equation for  $\rho_0$

$$\rho = d (C^2 + 1/4)$$

$$y = Y - K$$

y being the "height" (or radius) of the cone taken from the centerline of the cone

$$Y = (\sqrt{\rho^2 + X^2})$$

$$y = (\sqrt{\rho^2 - X^2}) - K$$

Substitute K and R from above

$$y = (\sqrt{d (C^2 + 1/4)^2 - X^2}) - d (C^2 - 1/4)$$

The radius of curvature of the circle is selected such that the joint between the nose cone and body tube is smooth.

### 3. AERODYNAMIC FORCES AND MOMENTS

The forces and moments can be obtained by integrating the pressure and moment over the entire surface. The forces and moments are normally expressed in coefficient forms, the normal ( $C_N$ ) and axial ( $C_A$ ) force coefficients. Forces can be analyzed using Newtonian theory and Modified Newtonian theory (MNT).

#### 3.1 Newtonian Theory

In this theory, the pressure coefficient depends only on the local surface deflection angle and not on any other aspect of the surrounding flow field. Newton originally assumed that the medium around a body was composed of identical non-

interfering independent particles. When these particles collide with the surface they lose their normal component of the momentum resulting in a pressure force on it. After collision, the particles move along the surface with their tangential component of the momentum unchanged. The regions of the body that do not see the oncoming particles directly are said to be in the shadow region and the pressure coefficient in these regions are normally set equal to zero.

The total normal momentum is  $\rho_\infty V_\infty^2 \sin^2 \alpha$ . This momentum is transferred to the surface element and acts as the normal pressure force. Here  $V_\infty \sin \alpha$  is the normal component of the velocity

$$\text{Normal pressure Force} = \rho_\infty V_\infty^2 \sin^2 \alpha$$

If Normal pressure force per unit surface area is the difference in pressure above the free stream, we have

$$P - P_\infty = \rho_\infty V_\infty^2 \sin^2 \alpha$$

$$C_p = (P - P_\infty) / (0.5 \rho_\infty V_\infty^2) = 2 \sin^2 \alpha$$

The surface pressure is fairly well predicted by the above Newtonian theory. It is to be observed that according to the Newtonian theory the pressure coefficient is independent of the Mach number.

#### 3.2 Modified Newtonian Theory

In this theory, the pressure coefficient is written as

$$C_p = k \sin^2 \alpha$$

Various values of k have been suggested depending on the Mach number, body shape, angle of attack and ratio of specific heats. The most common one is:

$$K = C_{ps}$$

Where,  $C_{ps}$  is the stagnation pressure coefficient behind a normal shock.

For this case, we have

$$k = \left\{ \frac{2}{\gamma M_\infty^2} \right\} \left[ \frac{(\gamma + 1)^2 M_\infty^2}{4\gamma M_\infty^2 - 2(\gamma - 1)} \right]^{1/\gamma - 1} \left[ \frac{1 - \gamma + 2\gamma M_\infty^2}{(\gamma + 1)} \right]^{-1}$$

For pointed cones and ogives, the suggested value for K is:

$$k = 2.1 + 0.5 [(M_\infty^2 - 1)^{1/2} \sin \text{arc tan } (0.5 k^* d / L_N + \alpha)] - 1$$

Where,  $k^* = 1$  for cones and  $k^* = 0$  for ogives, d = body diameter,  $L_N$  = nose length and  $\alpha$  = angle of attack

#### 3.3 Forces

According to the MNT, the coefficient of pressure is

$$C_p = k (\sin\theta \cos\alpha - \sin\alpha \cos\theta \sin\beta)^2$$

Where,  $\theta$  is the angle made by surface of body with body axis,  $\alpha$  is the angle of attack of the body axis,  $\beta$  is the polar angle of any point on body surface (measured from positive xy plane and positive for counterclockwise direction when viewed from rear) (Figure 2).

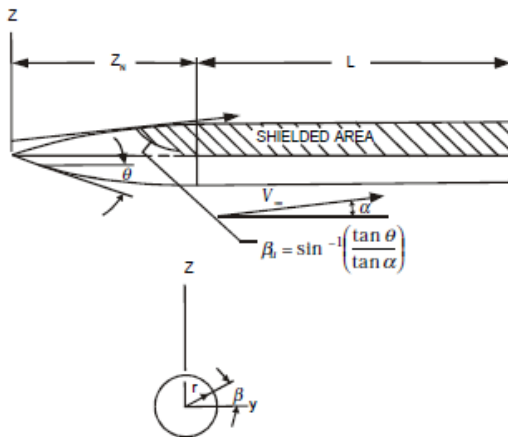

**Fig -2:** Representation of ogive curve by Modified Newtonian Theory

Experiments have indicated that the largest negative value of  $C_{pu}$  appears to be of the order of  $-1/M^2_\infty$  for  $\gamma=1.4$ . Therefore, for high Mach number flows, it is reasonable to assume that the shielded regions do not contribute to the forces and moments.

### 3.3.1 Axial Force

The axial force coefficient on a body can be considered to be made up of three parts,

$$C_A = C_{Af} + C_{Ab} + C_{AN}$$

Where,  $C_{Af}$  is the coefficient of axial force on the body due to skin friction,  $C_{Ab}$  is the coefficient of axial force due to the pressure on the base area, and  $C_{AN}$  is the coefficient of axial force on the body excluding friction (Wave drag).

For any portion of the body shown in Fig. 2, the axial force,  $A$  is given by

$$A = 2q_\infty \int ds \{ \int C_{pl} r \sin\theta d\beta + \int C_{pu} r \sin\theta d\beta \}$$

For lower surface, integral limits are from  $-\pi/2$  to  $\beta_u$  and for upper surface,  $\beta_u$  to  $\pi/2$ .

$$C_{pu} = 0 \text{ and } ds = dx / \cos\theta$$

$$C_A = A / q_\infty S_{ref}$$

$$dC_A/dx = (2kr/S_{ref}) \tan\theta [\sin^2\theta \cos^2\theta [(\beta_u + 0.5\pi) + \cos^2\theta \sin^2\alpha + (0.5\beta_u + 0.25\pi - 0.25 \sin^2\beta_u) + 2 \sin\theta \cos\alpha \cos\theta \sin\alpha \cos\beta_u]$$

The above equation can be integrated analytically to give axial force.

$$C_{Aogive} = k [2(1+F^2) \{1 - F^2 \ln((1+F^2)/F^2)\} - 1] [1 + 0.22F^2 \sin^2\alpha (M^2 - 1)] \pi d^2 / 4S_{ref}$$

Where,  $F = L_N/D$  is the fineness ratio.

#### 3.3.1.1 Skin Friction Coefficient

Axial skin friction coefficient,  $C_{Af} = C_f (S_{wet}/S_{ref})$

According to Blasius relation,

$$C_f = (1.328/\sqrt{Re})(C_f/C_{f1})$$

Where,  $C_f/C_{f1} = 1 - 0.0689 M_\infty - 0.0343 M^2_\infty + 0.0061 M^3_\infty - 0.000278 M^4_\infty$

#### 3.3.1.2 Base Pressure Coefficient

Based on experimental data, various empirical formulae have been suggested. A few of these formulae are:

$$\Delta CD_{base} = - C_{pbase} (S_{base}/S_{ref})$$

Where,  $C_{pbase} = (2/\gamma M^2_\infty) [(2/\gamma + 1)^{1.4} (1/M^2_\infty)^{2.8} \{2\gamma M^2_\infty - ((\gamma - 1)/(\gamma + 1)) - 1\}]$

$$C_{Ab} = (0.0071 M_\infty + 0.782) (0.004714 M^2_\infty - 0.06307 M_\infty + 0.2455) \pi d^2 / 4S_{ref}$$

It has been experimentally observed that for  $M \geq 5.5$ , there is very little effect of angle of attack on the base pressure. It is well known that as the Mach number becomes very high, the base drag coefficient approaches zero.

### 3.3.2 Normal Force

As the axial force, the normal force is given by:

$$N = -2q_\infty \int dx \{ \int C_{pl} r \sin\beta d\beta + \int C_{pu} r \sin\beta d\beta \}$$

For lower surface, integral limits are from  $-\pi/2$  to  $\beta_u$  and for upper surface,  $\beta_u$  to  $\pi/2$ .

$$C_N = N / q_\infty S_{ref}$$

$$dC_N/dx = (kr/S_{ref}) \sin^2\alpha \cos^2\theta [(\beta_u + 0.5\pi) \tan\theta + (\cos\beta_u/3) (\cot\alpha \tan^2\theta + 2\tan\alpha)]$$

The above equation can be integrated analytically or numerically to give normal force.

$$C_{Nogive} = k (\sin\alpha \cos\alpha) \sin\alpha F^2 [2(1+F^2) \ln \{(1+F^2)/F^2\} - 2]$$

$$\pi d^2 / 4 S_{ref}$$

### 3.3.3 Lift and Drag

Lift and Drag Force can be obtained from axial force and normal forces by the following relations (Figure 3):

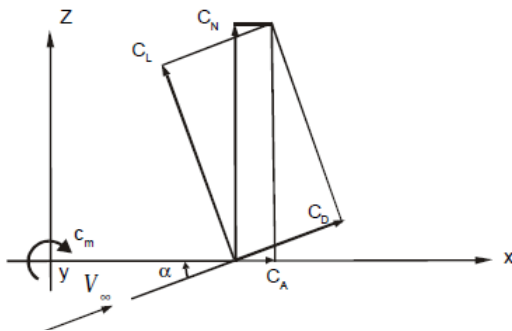

Fig -3: Relation between forces

$$C_L = C_N \cos\alpha - C_A \sin\alpha$$

$$C_D = C_A \cos\alpha + C_N \sin\alpha$$

$$C_N = C_L \cos\alpha + C_D \sin\alpha$$

$$C_A = C_D \cos\alpha - C_L \sin\alpha$$

### 3.4 MOMENTS

Moment is calculated by normal force equations, moment, taken about the centroid of the area of the base of the nose section and is given by:

$$M = -k q_{\infty} \int \{ (L_N - x) - r \tan\theta \} dx \left( \int C_{pl} r \sin\beta d\beta + \int C_{pur} \sin\beta d\beta \right)$$

For lower surface, integral limits are from  $-\pi/2$  to  $\beta_u$  and for upper surface,  $\beta_u$  to  $\pi/2$ .

$$dC_m/dx = (kr/S_{ref}L) \sin^2\alpha \cos^2\theta [(L_N - x) - r \tan\theta] [(\beta_u + 0.5\pi) \tan\theta + (\cos\beta_u/3)(\cot\alpha \tan^2\theta + 2\tan\alpha)]$$

Pitching moment from the integration of the above equation, where the moment is taken about the centroid of the base of the nose and taking the length of nose as the reference length, the pitching moment coefficient, for the case of a cone is given by:

$$C_{mogive} = [(C_{Nogive}/L_{ref}) (L_{mr} - L_N) + 3k (\sin\alpha + \cos\alpha) \sin\alpha F^2 (1+F^2) \{1 - F \arctan(1/F)\} - 0.33] \pi d^3 L_N / 4 S_{ref} L_{ref}^2$$

Where, F is the fineness ratio,  $L_{mr}$  is the moment arm length measured from the nose and  $L_{ref}$  is the reference length in the moment coefficient expression.

## 4. CONCLUSION

The tangent ogive nose cones provide a healthy compromise between structural integrity and weight and drag considerations. Also, the mathematical modeling of tangent ogive nose cones is comparatively easier than that of secant ogive and power-series nose cones. For the same fineness ratio, ogive shapes exhibit superior performance characteristics when compared to conical and bi-conical.

## REFERENCES

- [1] T V Karthikeyan, A K Kapoor, "Guided Missiles", DRDO Metcalfe House, Delhi, 1990
- [2] S S Chin, "Missile configuration design handbook".
- [3] AK sreekanth, "Aerodynamic predictive methods and their validation in hypersonic flows", DRDO India.
- [4] Sampo Niskanen, "Open Rocket technical documentation".
- [5] B. Tyler Brooker, Semih M. Olcmen, John Baker and Keith A. Williams, "Experimental study on the effects of nose geometry on drag over axisymmetric bodies in supersonic flow", Department of Aerospace Engineering and Mechanics in the Graduate School of The University of Alabama.
- [6] B. Kaleeswaran, S. Ranjith Kumar and Jeniwer Bimro. N, "An Aerodynamic Optimization of Supersonic Flow Over The Nose Section of Missiles", International Journal of Engineering Research & Technology (IJERT), Vol. 2 Issue 4, pp. 253-262.
- [7] Ryan J. Felkel, "Effect of Different Nose Profiles on Subsonic Pressure Coefficients", American Institute of Aeronautics and Astronautics, pp. 1-10.
- [8] M. R. Heidari, M. Farahani, M. R. Soltani and M. Taeibi-Rahni, "Investigations of Supersonic Flow around a Long Axisymmetric Body", Wind Tunnels and Experimental Fluid Dynamics Research, pp. 569-584.