

# Performance Analysis of 50km Long Fiber Optic Link using Fiber Bragg Grating for Dispersion Compensation

Mr. Tushar Kant Panda<sup>1</sup>, Ananta Narayana Sahu<sup>2</sup> and Anurag Sinha<sup>3</sup>

<sup>1</sup>Asst. Professor, Gandhi Institute Of Engineering and Technology, Gunupur  
tusarkantpanda@gmail.com

<sup>2</sup>Under Graduate, Gandhi Institute Of Engineering and Technology, Gunupur  
anantasahu485@gmail.com

<sup>3</sup>Under Graduate, Gandhi Institute Of Engineering and Technology, Gunupur  
anuragsinha106@gmail.com

\*\*\*

**Abstract:**—Optical fiber is one of the most advanced communications media in communication system. Due to its versatile advantages and negligible transmission loss, it is used in high speed data transmission and accurate data transmission. Although optical fiber communication has a lot of advantages, dispersion is the main performance limiting factor. Fiber Bragg Grating is a well known dispersion compensating method having some superior advantages in the field of optical fiber communication. This paper discusses the use of FBG to compensate dispersion in a 50 km long fiber optical link. NRZ modulation formats is used at transmitter side and the results thus obtained are compared. Different transmission power levels are used to transmit data and their results are compared. The value of Q-factor, eye height and bit error rate (BER) is determined for each and every case and their values are compared.

**Keywords :**Dispersion, Fiber Bragg Grating, Dispersion compensation, Grating Length, Q-factor, Min BER, Power Levels, Eye Height, Amplifier gain, Optisystem 14.0.

## 1. INTRODUCTION

Optical fiber communication is nothing but a method of transmitting information from one place to another by sending light as information carrier through optical fiber. Optical communication system faces problems like dispersion, attenuation and non-linear effects that lead to deterioration in its signal. Dispersion affects the most, among all the above mentioned and it is tough to overcome as compared to other [1]. Thus, it is important to solve this problem by an effective dispersion compensation technique that leads to performance enhancement of the optical system. Fiber Bragg grating is a periodic perturbation of the refractive index along the core of the optical fiber [2]. It has an important role in optical communication system especially when designing optical amplifiers and filters. The modulation of the refractive index can be achieved by exposing the core of the fiber to ultra-violet radiation. This produces change in the refractive index of the core. FBG reflects particular wavelengths of light and transmits all

others due to a periodic variation in the refractive index of the fiber core which generates a wavelength-specific dielectric mirror. A Fiber Bragg Grating can therefore be used as an inline optical filter to block certain wavelengths.

## 1.1 DISPERSION

Dispersion is one of the main limiting factor which is responsible for the degradation in the overall performance of fiber optic communication. As optical pulses travels through single mode fiber because of dispersion broadening of optical pulse is observed. At high data rate, these broaden pulses may overlap with each other causing crosstalk and inter symbolic interference (ISI) which causes errors during reception of the signal at the receiver side of optical link [3]. Due to the broadening of pulse the received optical power is reduced to [4]. In single-mode fiber, chromatic dispersion is the primary limitation (also called group velocity dispersion) which occurs because the index of the glass varies slightly depending on the wavelength of the light, and real optical transmitters transmits light necessarily has nonzero spectral width. Polarization mode dispersion is another type of dispersion which occurs because, it can carry this mode with two different polarizations, and slight interference or distortions in a fiber alter the propagation velocities for the two polarizations [5], which is called birefringence. Dispersion can be compensated by using different dispersion compensation methods. One of the most effective way to compensate dispersion is by using Post Fiber Bragg Grating. The dispersion is proportional to the length of the fiber. If the length is increased the width becomes bulk and the magnitude reduces [6].

## 2. FIBER BRAGG GRATING

The basic principle behind the operation of an FBG is Fresnel reflection, where light travels in between media's of different

refractive indices and thus may reflect and refract at the interface [7].The refractive index alternate over a defined length and limited to a certain range of values. The reflected wavelength ( $\lambda_B$ ), called the Bragg wavelength. Mathematically it can be expressed as below,

$$\lambda_B = 2n_e\Lambda$$

where  $n_e$  is the effective refractive index of the grating in the fiber core and  $\Lambda$  is the grating period. The effective refractive index quantifies the velocity of propagating light as compared to its velocity in vacuum.  $n_e$  depends on two parameters, wavelength and mode in which the light transmits. For this reason, it is also called modal index.

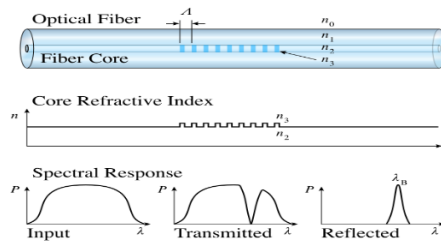

Fig 1 : A Fiber Bragg Grating structure, with refractive index profile and spectral response

The wavelength spacing between the first minima or the bandwidth ( $\Delta\lambda$ ), is (in the strong grating limit) given by,

$$\Delta\lambda = \left[ \frac{2\delta n_0 \eta}{\pi} \right] \lambda_B$$

Where  $\delta n_0$  is the variation in the refractive index ( $n_3 - n_2$ ), and  $\eta$  is the fraction of power in the core. Note that this approximation does not apply to weak gratings where the grating length,  $L_g$ , is not large compared to  $\lambda_B \setminus \delta n_0$ .

### 2.1 GRATING STRUCTURE

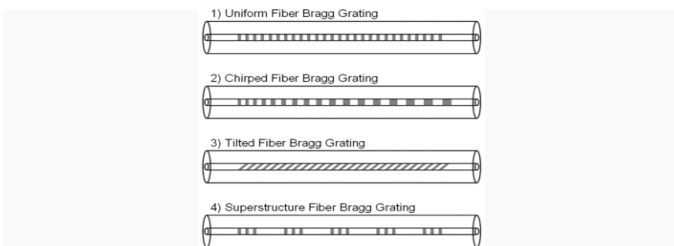

Fig 2 : Structure of the grating in (1) Uniform FBG; (2) chirped FBG; (3) Tilted FBG (4) Superstructure FBG

The structure of the FBG may vary with respect to the refractive index, or the grating period [8]. The grating period can be uniform or graded, and either localized or distributed in a superstructure. The refractive index profile and offset is the two primary characteristics of the refractive index [9]. Typically, the refractive index profile can be uniform or apodized, and the refractive index offset is positive or zero. There are six different types of structures are present for FBGs:

1. Uniform optical fiber
2. Gaussian apodized optical fiber,
3. Raised-cosine apodized optical fiber,
4. Chirped fiber[10]
5. Discrete phase shift fiber
6. Superstructure fiber[11]

### 2.2 CHIRPED FIBER BRAGG GRATINGS

The refractive index profile of the grating is modified in a certain format which adds more features to the fiber, such as a linear variation in the grating period, called a chirp [12].These fibers can operate over the normal temperature range for telecommunication system. Hence enhance the system performance.

#### ADVANTAGES:

- cost effective
- low insertion loss
- passive component compatibility with smf

#### APPLICATIONS:

- used in wdm add/drop filters.
- used in pump laser.
- Helps in stabilising the wave length in wave length stabilizer.

### 3. SIMULATIONS SETUP

In this paper, simulations have been performed using NRZ modulation formats at different transmission power levels and different SMF lengths and grating length. Various simulations parameters utilized in this analysis work are given in Table no.1 and various fiber parameters used in this simulation is given in Table no. 2.

Table no. 1 Simulations Parameters

PARAMETERS	SMF
Length	50(km)
Attenuation	0.2(db/km)
Dispersion	16(ps/nm/km)
Dispersion slope	0.08(ps/nm <sup>2</sup> /km)

Table no. 2 Fiber Parameters

PARAMETERS	VALUES
Bit rate	10e+009
Sequence length	128
Sample per bit	64
Central frequency	193.1THz
Extinction ratio	30db

Simulation setup used in this analysis are given below:

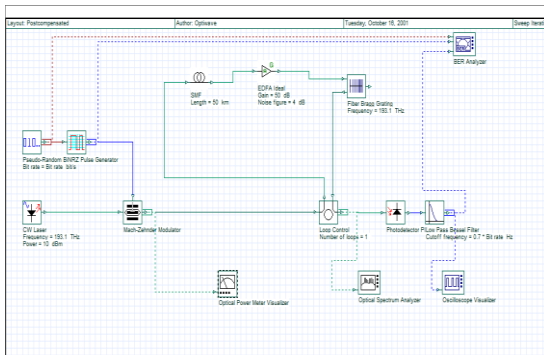

At first we have used a pseudo-random bit generator which transmits a sequence of 0's and 1's which are fed into the input stage of NRZ modulators. This string of 0's and 1's is converted into electrical pulses which are fed to input of Mach Zehnder Modulator which modulates the signal with a continuous wave centered at frequency 193.1 THz. The signal is then fed to an SMF of length 50km. An EDFA is used to compensate loss due to large span of single mode fiber. Then the signal is passed through the FBG for compensation. The optical information signal is then retrieved by PIN photo diode which converts optical signal to electrical signal. This signal is passed through an LPF in order to remove all high-frequency noise. Finally the signal is analyzed by BER which determines various performance parameters such as BER, Q-factor, eye height.

**4. RESULTS AND DISCUSSIONS**

In this system evaluation has been done on the performance of Fiber Bragg Grating in order to compensate dispersion. Here all the parameters has been changed to get an optimized output at the end, and the SMF length has kept constant at 50 km. Here we have changed parameters like grating length, laser power and amplifier gain values .In order to carry out various simulations, Optisystem 14.0 has been used. The different values of eye height and Q-factor are compared as below in the tables.

6	21.3276	3.08099e-101	0.0596014
7	24.4078	6.79684e-132	0.0681819
8	27.9426	3.771667e-172	0.0746111
9	24.9283	1.79734e-137	0.076905
10	21.1323	1.9963e-099	0.0768468

Table no.3 output at different values of grating length

Power input (mw)	Q-factor	Min-BER	Eye height
1	20.9695	5.59688e-098	0.006134780
2	20.9799	4.51426e-098	0.007737078
3	20.922	1.53143e-097	0.00973914
4	20.103	105964e-096	0.0122677
5	20.6302	6.81336e-095	0.054502
6	20.3764	1027031e-092	0.0194555
7	20.0401	1.17255e-089	0.0244953
8	19.6133	5.76581e-086	0.0308358
9	19.0872	1.58679e-081	0.0388108
10	18.4597	2.16625e-076	0.0488406

Table no. 4 output at different values of input power

Amp gain (db/m)	Q-factor	Min-BER	Eye height
10	18.4981	1.06369e-076	0.0048516
20	18.4597	2.16625e-076	0.0488406
30	18.4453	2.8267e-076	0.488356
40	18.4406	3.0874e-076	4.88339
50	18.439	3.17601e-076	48.8333

Table no.5 output at different values of amplifier gain

Grating length(mm)	Q-factor	Min BER	Eye height
1	11.9239	4.39123e-033	0.00305773
2	13.0958	1.73266e-039	0.0115586
3	14.6353	8.35273e-049	0.0235349
4	16.5032	1.73812e-061	0.0365926
5	18.4597	2.16625e-076	0.0488406

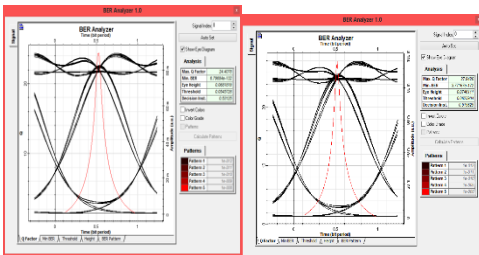

Fig 3 : Grating length at 7mm Fig 4 : Grating length at 8mm

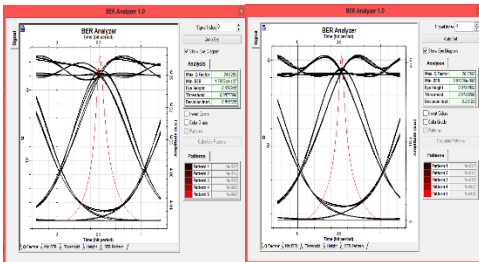

Fig 5 : Grating length at 9mm Fig 6 : Power input at 5mw

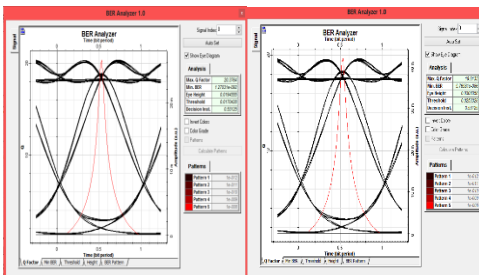

Fig 7 : Power input at 6mw Fig 8 : Power input at 7mw

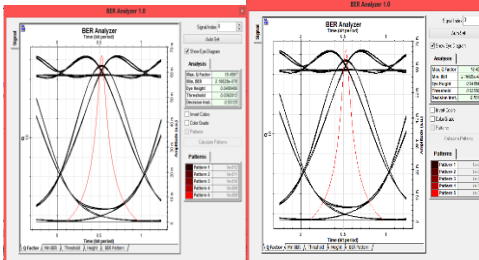

Fig 9 : Amp gain at 20 db/m Fig 10 : SMF length at 50 km

### 5. CONCLUSION

This paper enlightened the use of FBG in order to compensate dispersion loss in optical fibers. From the above simulations we got some optimised value for 50km long distance communication. Optimised output can be achieved if the grating length is in between 7,8,9(mm), power input is nearly 5,6,7(mw), amplifier gain is nearly 20db. At these values the important parameters like BER, eye height, Q-factor is found to be better and satisfactory for the real time application and the spectrum analyser output is also found to be better and satisfactory as shown in the above figure. Hence error free signal can be achieved in the range of 50km. In order to achieve least error, another method can also be

introduced i.e. Polarization Mode Dispersion Compensation Method.

### 6. REFERENCES

- [1] Zou X Y, Hayee M I, H wang S M, et al. Limitations in 10Gb/s WDM optical-fiber transmission when using a variety of fiber types to manage dispersion and nonlinearities[J]. Lightwave Technol., PP: 1144
- [2] Jianjun Yu, Bojun Yang, "Dispersion-allacated soliton technology with long amplifier spacing and long distance," IEEE photon technol lett, vol 9, pp. 952-954, No.7, 1997.
- [3] A.Yariv, D.Feke, D.M.Pepper, Opt.Lett.4 (1979) 52.
- [4] GiulianiG. and Alessandro D.D', " Noise analysis of conventionaland gain-clamped semiconductor optical amplifiers," IEEE Journal of Light wave Technology, Vol. 18, pp. 1256-1263, Sept. 2000.
- [5] R.S.Kaler, T.S.Kamal, A.K.Sharma, S.K.Arya ,R.A. Aggarwala, J.Fiber Integrated Opt.21 (3) (2002) 193
- [6] R.J.Nuyts, Y.K.Park, P.Gallison, Photon. Technol. Lett. 8 (1996) 1406.
- [7] R.M.Jopson, A.H.Gnaules, R.M.Derosier, in : Proc. OFC'93, paper pd3, 1993.
- [8] A.K.Sharma, R.K.Sinha, R.A.Agarwala, J.Opt.Fiber Technol.4 (1998) 135.
- [9] T.L.Koch, R.C.Alferness, J. Light wave Technol. LT-3(1985) 800.
- [10] J.J.O'Reilly, M.S.Chauldry, IEEE, Colloquim Microwave Optoelectron.139 (1990) 13/1.
- [11] Wikipedia
- [12] MoritoK., EkawaM., WatanabeT., FujiiT. and KotakiY., " High saturation output power (+17dBm) 1550nm polarization insensitive semiconductor optical amplifier," 26<sup>th</sup> Europ. Conf. Optical Communication ECOC2000, Munich, Germany, pp. 39-41, September 3-7, 2000.