

# Optimal System for Manipulating Mouse Pointer through Eyes

Anamika Mali<sup>1</sup>, Ritisha Chavan<sup>2</sup>, Priyanka Dhanawade<sup>3</sup>, Prof. Manoj Mulik<sup>4</sup>

<sup>1</sup>Anamika Mali, Dept. Of Computer Engineering, APCOER, Maharashtra, India

<sup>2</sup>Ritisha Chavan, Dept. Of Computer Engineering, APCOER, Maharashtra, India

<sup>3</sup>Priyanka Dhanawade, Dept. Of Computer Engineering, APCOER, Maharashtra, India

<sup>4</sup>Prof. Manoj Mulik, Head Of Dept., Computer Engineering, APCOER, Maharashtra, India

\*\*\*

**Abstract** - Mouse is invented for systems that were used to give the input to the Human – Computer interface which contains left button and right button and performed various operations. Many system were invented to replace the mouse and they have different ways for interacting to the computer. One of those systems is the Camera based system which used to take input from facial features of human being. The system introduced in this paper is a human computer interface for performing mouse operations using eyes. The idea is to make the mouse cursor hands free by using light-reflection based systems with non-imaging sensors, thus providing an alternative to computer mouse. It will capture the change in the iris positions with the help of IR sensors to track the point of gaze in order to translate it to some events that communicate with the computer. The system will perform the operation such as double click and single click by eye blinking and scrolling by eye movements. To reduce the cost and the size of this system we are using the DAQ, i.e., Data Acquisition which acts as the intermediate block between the Eye tracking goggle and the computer. This system will provide an easy way to access the computer for physically challenged people or those who are unable to use to hands.

**Key Words:** Eye tracking, Gaze, IR sensors, Cursor Movement, human-computer interface, Data Acquisition

## 1. INTRODUCTION

The interest for developing the Human-Computer interaction has been growing since last few years. Many systems for replacing the mouse has taken place but they are not feasible due the accuracy, cost and throughput of the system. Different invasive or non-invasive methods for eye movement measurement were investigated. Today, some vendor provides commercial remote camera-based eye-tracker systems for which the light source and camera are permanently fixed to a monitor. Our recent research was focused on new hardware and software solutions to improve the reliability, mobility and usability of the communication system. Eye tracking techniques measure the person's eye movements so that the gaze point at any time and

the eyes shifting are established accurately. The proposed eye tracking method was oriented towards the possibility to be used by patients for email, messenger and social sites. In this project we propose an eye tracking mouse (ETM) system using Eye touch glasses and a new robust eye tracking algorithm. The proposed system allows the patient to communicate his needs, to browse a graphical user interface and to select an image or a word, using only his eyes. The proposed system consists of DAQ which is used as micro-controller and IR sensors attached to glasses and the software application running the eye tracking algorithm. The IR sensors, mounted on a glasses frame, has a modified system lens in order to be used at a short suitable distance from user's eyes. There is a category of people with severe speech and motion impairment or with physical disabilities who cannot speak and cannot use sign language. If these patients have a good level of understanding and perception, they should use their eyes for Human Computer Interaction (HCI).

## 2. EXISTING SYSTEM

For experiencing the 3D (Some) touch effect for cursor movement the devices named Smart Thimble was introduced, which make the use the color bands for operation but it is expensive and not reliable for every person. The previously developed systems that were used to give the input to the Human – Computer interface. The disadvantage of these all system is that it needs more computational power, are expensive and sometimes are less reliable. Also video based eye tracking system was implemented in which a webcam was attached to the computer. In camera based system works as a three-phase feature-based gaze tracking approach that uses the features of eyes and the head pose information in order to gain the accuracy of the point of gaze estimation. In first phase the eye region is detected that is containing the information regarding to the eyes. Then the corner of eyes and the center of the iris is detected which is forming the eye vector. In

second phase the mapping functions parameters are obtained that gives the relationship between the point of gaze on screen and the eye vector. For computing the mapping between eye vector and coordinates of the monitor the calibration process is used. In third phase the head position and the gaze point is mapped, it combines the eye vector with the head position information to obtain the point of gaze.

### 3. PROPOSED SYSTEM

The eye tracking system is composed of the following components: Goggle, Data Acquisition device, Software and external power supply. The eye tracking system is designed in manner to discover the eye blinks and the eye gaze direction of real time. The system is capable due the following facts

1. The human eyes are mainly having two parts that are able to distinguish with respect to color, the sclera and iris. The sclera has white color and the iris consists of the darker tones usually black, brown, etc. All human eye have fixed color distribution in infrared range.
2. Different colors reflects different values and different wavelengths.

To achieve accurate point of gaze the user should maintain the steady head pose. Each component of the system has the following importance in this system.

#### 3.1 Goggle

Eye Touch is one of the light-reflection-based eye tracking systems that is implemented by placing IR LEDs and photo transistors around an eyeglasses frame. The goggle consist in all 12 IR sensors; consisting 6 sensors on each side. 3 sensors are placed horizontally and 3 vertically to detect the eye gaze and the eye movement. The glasses are attached to the DAQ with the help of a cable. Also the use of gyroscope is done to detect the up and down moments of eyes, the gyroscope works in x, y and z direction. As infrared light is not visible to human eyes, the LEDs in IR sensors emits the infrared light on the eyes continuously and the reflection of the light is captured by the photo transistor. If there is any change in the eye position or if the blinking is done then the photo transistor captures the difference in the intensity of the light and passes the input to the DAQ.

#### 3.2 DAQ

The DAQ is a bridge between the PC and goggle that gains the input from the goggle and gives output to the computer software about the action to be taken. The DAQ consists of following components: microcontroller, analog to digital convertor, power supply, RS232 and a USB port. The power supplied to the DAQ is in analog form which is converted to digital using the analog to digital convertor. The USB port is for connecting the DAQ with the computer where the data is set serially. The RS232 connector allows the DAQ to establish serial connection with the goggle for acquiring the values of eye movements and the point of gaze. The DAQ provides continuous power supply to the goggle for enabling the sensitive measurements to avoid and eliminate the noisy data. Also the analog data from the goggles is collected, digitized, processed for obtaining the eye vectors and is then passed to the computer software for further processing. The DAQ that is to be designed is capable of running with a sampling rate of 10 Hz.

#### 3.3 Software

The purpose of software in project is to map whatever values the hardware gives and depending on that values perform the tasks of mouse movement or mouse press, release by obtaining the permission from the kernel. For obtaining the control of the mouse at kernel level robot class is used that performs test automation, self-running for generating the native system input events. The software plots the respective position dynamically on the screen whenever the movement is done. Also the software servers as an interface between the user and the hardware.

### 4. TECHNOLOGY

#### 4.1 IR sensors

An infrared sensor is an electronic instrument which is used to sense certain characteristics of its surroundings by either emitting or detecting infrared radiation. IR sensors are also capable of measuring the heat being emitted by an object and detecting motions. Infrared waves are not visible to the human eye. In the electromagnetic spectrum the infrared radiation can be found between the visible and microwaves bands.

a. Working of IR sensor

An IR sensor is used to detect obstacles in front of the robot or to differentiate between colors depending on the configuration of the sensor. The picture shown is a very simple black box model of the IR sensor. The sensor emits IR light and gives the signal when it detects the reflected light. An IR sensor consists of emitter, detector and associated circuitry. The circuit required to make an IR sensor consists of two parts; the emitter circuit and the receiver circuit. The emitter is simply an IR LED (Light Emitting Diode) and the detector is simply an IR Photodiode which is sensitive to IR light of the same wave length as that emitted by the IR LED. When IR falls on the photodiode, its resistance and correspondingly, its output voltage, changing proportion to the magnitude of the IR light received. This is the underlying principle of working of the IR sensor.

b. Detection of Black and White surface

IR sensors are also used to detect the black and white surfaces. White surfaces reflect all types of light while black surfaces absorb them. Therefore, depending on the amount of light reflected back to the IR receiver, the IR sensor can also be used to distinguish between black and white surfaces.

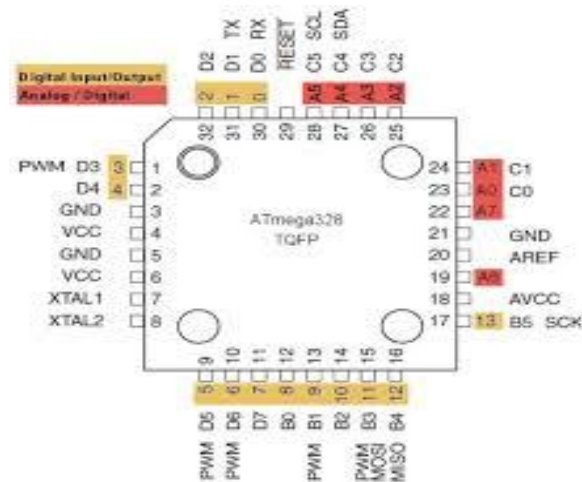

Fig -1: ATmega328 Pin diagram

4.3 Gyroscope

A Gyroscope is a spinning wheel or disc in which the axis of rotation is free to assume any orientation by itself. When rotating, the operation if axis is unaffected by tilting or rotation of mounting, according to the conservation of angular momentum. Because of this gyroscope are useful for measuring or maintaining orientation. The key functionality of gyroscope is for head movement tracking in 3 dimension space in up and down position calibration of head and also considering the side way movement in only x and y direction.

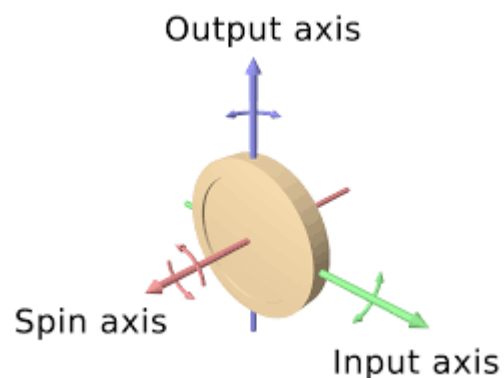

Fig -2: Gyroscope

Hence it becomes necessary for calibration of the mouse movement when moves in upper direction, i.e. looking up and down respectively. Gyroscope is useful whenever z axis is considered or in either case if we had considered only 2 dimensions we would have used an accelerometer which considers only 2 dimensions x and y.

## 5. CONCLUSIONS

In our project, we focused on the analysis of the development of hands-free PC control - Controlling mouse cursor movements using human eyes. Thus, the comprehensive study of the gaze-based interaction processes is implemented. Taking into account that many people with disabilities do not afford a suitable communication system, this low-cost system could successfully replace the more expensive ones. It exhibits accuracy and speed, which allow handicapped users to enjoy many computer activities. In fact, it was possible to completely simulate a mouse without the use of the hands. In future we tend to add some additional functionality for speech recognition which we would help disabled enter password or type and document verbally and also the connections can be done in wireless manner. Thus, the comprehensive study of the gaze-based interaction process is implemented.

## REFERENCES

- [1] Lupu R.G., Ungureanu F., Siriteanu V, "E-Health and Bioengineering – EHB 2013 Eye Tracking Mouse for Human Computer Interaction", the 4th IEEE International Conference.
- [2] Shrunkhala Satish Wankhede, Ms. S. A. Chhabria, "Controlling Mouse Cursor Using Eye Movement" International Journal of Application or Innovation in Engineering Management (IJAEM). ISSN 2319 4847
- [3] International Journal of Scientific and Research Publications, "Hands Free Pc Control Controlling Of Mouse Cursor Using eye Movement", Volume 2, Issue 4, April 2012 1 ISSN 2250-3153. R. Nicole, "Title of paper with only first word capitalized," J. Name Stand. Abbrev., in press.
- [4] D. W. Hansen and Q. Ji, "In the eye of beholder: A survey of models for eyes and gaze", IEEE Trans. Pattern Anal. Mach. Intell., vol. 32, no.3, pp. 478500, Mar. 2010.
- [5] X. Zheng, X. Li, J. Liu, W. Chen, and Y. Hao, "A portable wireless eye movement controlled human-computer interface for the disabled", in Proc. ICME Int. Conf. Complex Biomedical Eng., Tempe, AZ, USA, Apr. 2009, pp. 15.
- [6] A. Plotkin, O. Shafrir, E. Paperno, and D. M. Kaplan, "Magnetic eye tracking: A new approach employing a planar transmitter", IEEE Trans. Biomedical Eng., vol. 57, no. 5, pp. 12091215, May 2010.
- [7] A. Bulling, D. Roggen, and G. Trster, "Wearable eog goggles: Eye-based interaction in everyday environments", in Proc. ACM Conf. Human Factors Comput. Syst., Boston, Massachusetts, USA, 2009, pp. 32593264.
- [8] C. Topal, O. N. Gerek, and A. Dogan, "A head-mounted sensor-based eye tracking device: Eye touch system", in Proc. ACM Symp. Eye Tracking Res. Appl., Savannah, GA, USA, 2008, pp. 8790.