

# NONLINEAR CURRENT CONTROLLER FOR A SINGLE PHASE GRID CONNECTED PHOTOVOLTAIC SYSTEM

Dhanashri P. Dhande<sup>1</sup>, Prof. A. P. Chaudhari<sup>2</sup>, Prof. N. S. Wani<sup>3</sup>

<sup>1</sup> Student (ME), Electrical Engineering , SSGB COET BHUSAWAL, MAHARASTRA,INDIA.

<sup>2</sup> Assistant professor, Electrical Engineering, SSGB COET BHUSAWAL, MAHARASTRA,INDIA.

<sup>3</sup> Assistant professor, Electrical Engineering, SSGB COET BHUSAWAL, MAHARASTRA,INDIA.

\*\*\*

**Abstract** – This paper gives a new nonlinear current control method for a single-phase grid-connected photovoltaic (PV) system. Partial feedback linearization is used for designing the controller, which linearizes the system partially and to make possible the controller design scheme for reduced-order PV systems. The reference current is calculated from the maximum power point tracking system (MPPT). The suggested current control approach introduces the internal dynamics and the stability of the internal dynamics is a key requirement for the implementation of the controller to analyze the stability of internal dynamics of a PV system. Based on the tracking of grid current to the reference current, the performance of the controller is evaluated by considering the changes in environmental conditions. A large system comparable to a practical system is simulated under different operating conditions such as at a standard atmospheric conditions, change in atmospheric condition and faults on different parts of the system and compared with conventional controllers, which ensures the suitability of the proposed controller in a real system. The experimental validation of the proposed control scheme is also presented in this paper.

**Key Words:** Grid Connected PV (Photovoltaic) system, MPPT, Current Controller.

## 1.INTRODUCTION

In the field of power sector one of the major concerns in these days is day-by-day increase in power demand. But, the quantity and availability of conventional energy sources are not enough to meet up the current day's power demand. While thinking about the future availability of conventional sources of power generation, it becomes very important that the renewable energy sources must be utilized along with source of conventional energy generation systems to fulfill the requirement of the energy demand. In order to overcome current day's energy crisis, one renewable method is to extract power from the incoming sun radiation called Solar Energy, which is globally free for everyone. Solar radiation is widely available on the surface of earth as well as in space, so that we can harvest it and convert it into other form of energy and properly utilize it efficiently. Power generating

unit may feed power into the grid or it may be used in isolated systems. Utility location, load center, available grid connectivity decides its energy usage. Thus, where the availability of grids connection is very difficult or costly, the solar energy can supply power to those areas. The most important two advantages of solar power are that its fuel cost is absolutely zero and solar power generation during its operation does not produce any greenhouse gases. Easy carry-in of the power generating unit is another advantage that is we can use it whenever wherever small power generation is required. In the last few years the power conversion mechanisms for solar energy has been significantly reduced to compact size. The new researches in the field of power electronics and material science have greatly helped engineers to develop such systems. So that very small but effective and powerful systems that have capability to meet high electric power demand has been developed. For every country, day by day power density demand is increasing. Photovoltaic power generation is capable of mitigating voltage fluctuation very effectively by setting the system for the use of multiple input and converter units. But in solar power generation system, due to its high installation cost and the low efficiency of the solar cells, this power generating systems can hardly participate in the competitive power markets as a main renewable source of power generation.

### 1.1 System Development

The overall system consists of solar panel that generates power according to the irradiation levels. The MPPT algorithm calculates the duty cycle for the converter corresponding to the maximum power point. There will be one maximum power point for a particular irradiation. Most of electrical power applications are based on using solar energy, as it is basically unlimited and generally on hand energy resource. However, the output power induced in the photovoltaic modules depends on solar irradiance and temperature of the solar cells. This makes the extraction of maximum power a complex task. The efficiency of the PV generation depends on maximum power extraction of PV system. Therefore, to maximize the efficiency of the renewable energy system, it is necessary to track the maximum power point of the PV array. The PV array has a single in service point that can supply maximum power to the

load. This point is called the maximum power point (MPP). The locus of this point has a nonlinear distinction with solar irradiance and the cell temperature. Thus, in order to operate the PV array at its MPP, the PV system must contain a maximum power point tracking (MPPT) controller

### 1.2 MPPT

Maximum power point tracking (MPPT) is the method of tracking maximum output power from a solar panel. Several MPPT algorithms are available nowadays. The MPPT algorithm used in this particular work is non linear current control.  $P_m$  is the maximum power that can be obtained from a particular panel. The aim of a MPPT algorithm is to track  $P_m$  by making  $V_{pv}$  to VM or  $I_{pv}$  to IM.

### 1.3 PV System Module

The schematic diagram of a single-phase grid-connected PV system, which is the main focus of this project, is shown in Figure 1. The PV system consists of a PV array, a dc-link capacitor C, a single-phase inverter, and a filter inductor connected to the grid with the voltage. In this project, the main target is to control the current injected into the grid by means of appropriate control signals through the switches of the inverter.

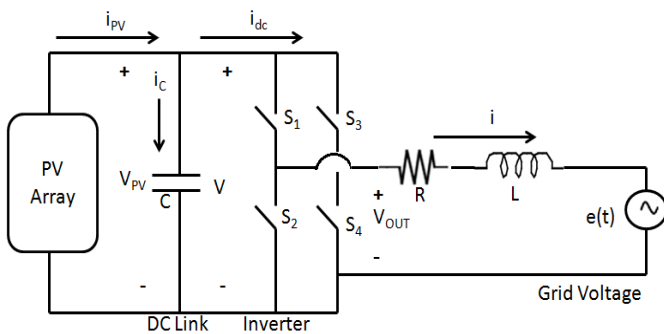

Fig-1. Equivalent Circuit Diagram of Single-Phase Grid-Connected PV System.

## 2. CONTROLLER PERFORMANCE EVALUATION

First, a simple single-phase grid-connected PV system and then a PV system, similar to the practical system, are considered to evaluate the performance of the designed controller. Finally, the designed control algorithm is validated through some experimental results. The implementation block diagram of a partial feedback linearizing controller for a single-phase grid-connected PV system is shown in Figure. 2, in which it can be seen that the magnitude of the reference current for the linear controller is obtained from the MPPT and the angle is extracted from the grid current using a PLL. The controller is a combination of a linear and partial feedback linearizing controller. Finally, the control input is implemented through the inverter switches using a pulse width modulation (PWM) technique where the switching frequency of the inverter is considered as 10 kHz.

### 2.1 Performance Evaluation on a Simple System

In this section, the performance of the designed controller is evaluated on the simple system. To simulate the performance at this stage, a PV array consisting of ten PV cells, characterized by a rated current of 2.0 A, is connected in parallel. There are two bunch of PV cell, characterized by a rated voltage of 76.5 V, and connected in series. Thus, the total output voltage of the PV array is 153 V, the output current is 10 A, and the total power is 750 W. The value of the dc-link capacitor is 1000µf. The line resistance is 0.1 Ω and the inductance is 10 mH. The grid voltage is 240V and the frequency is 50 Hz. The performance of the designed controller is evaluated under standard and changing atmospheric conditions through the following case studies.

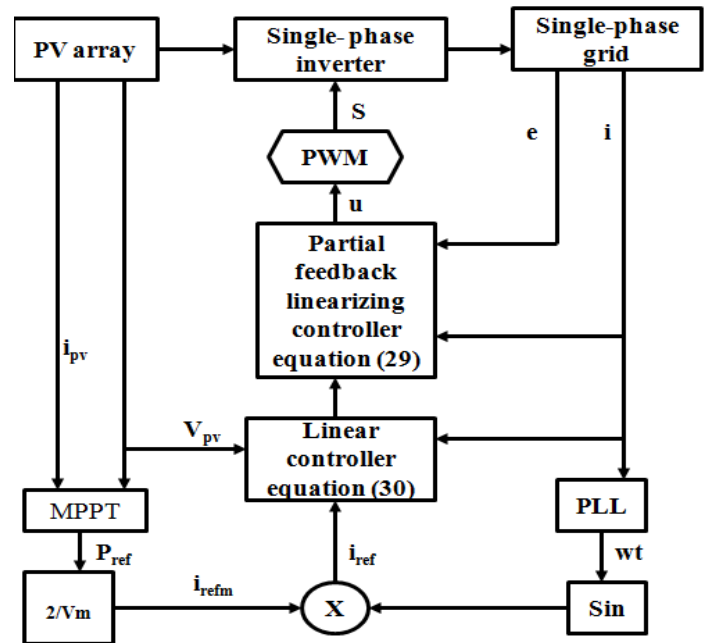

Fig-2. Implementation Block Diagram Of Partial Feedback Linearizing Controller.

#### Case 1: Controller Performance under Standard Atmospheric Conditions:

At this stage, the system is simulated under standard atmospheric condition in which the solar irradiance is considered as and the temperature as 298 K. At this condition, the output power of the PV unit from which it can be seen that there are some fluctuations due to the nonlinear characteristics of the PV system. The main purpose of the control action is that the grid current will follow the reference current when the maximum power extraction from the MPPT is 700W. This can be performed by regulating the inverter switches through the proper control scheme when the MPPT is achieved. Here comparison is shown in this nonlinear grid current (violet) and hysteresis grid current (yellow line) are shown in Figure.3 and 4 from 0 to 0.5 s with the proposed control scheme.

### Case 2: Controller Performance under Changing Atmospheric Conditions:

In a practical PV system, the atmospheric condition changes continuously for which there exists variations in the cell's working temperature and solar irradiation. Due to the changes in atmospheric conditions, the output voltage, current, and power of the PV unit change significantly. For example, if a single module of a series string is partially shaded, its output current will be reduced which will indicate the operating point of the whole string. Figure. 6 and 7 shows the performance of the proposed current controller with changes in atmospheric conditions. From Figure 5 and 6, it can be seen that the PV system operates under standard atmospheric conditions from 0. to 0.5 s. But the irradiation changes from 1000 to 700 w/sq.m at 0.2 s and the weather remains cloudy, i.e., the PV system is shaded until 0.2s to 0.35s. At this stage, the amount of power delivered to the grid will be changed and the MPPT will select a different MPP, but the grid voltage will be the same. The change in the grid current is also shown in Figure 6 and 7. After 0.35 s, with the proposed controller, the non linear current controller grid current (violet line) is similar to its previous value as the system again operates at standard atmospheric conditions, but the hysteresis current controller (yellow line) is not capable to track the reference current accurately.

### Case 3: Controller Performance During Fault:

A line-to-ground fault is considered at an instance at the terminal of PV unit to evaluate the performance of the proposed current controller. When such faults are applied, PV units will not supply any power into the grid and load. Under this case study, the performance of the proposed controller is shown in Figure 5 from where it can be seen that the PV unit is not injecting any current into the grid from 0.25 to 0.35 s as the fault is applied for this period. In this case study, the pre-fault and post-fault conditions are considered as standard atmospheric conditions. The proposed controller maintains the post-fault steady state as soon as the fault is cleared but with the hysteresis controller the system becomes unstable. The simulation results show the superiority of the proposed control scheme.

### 5. Simulation Results:

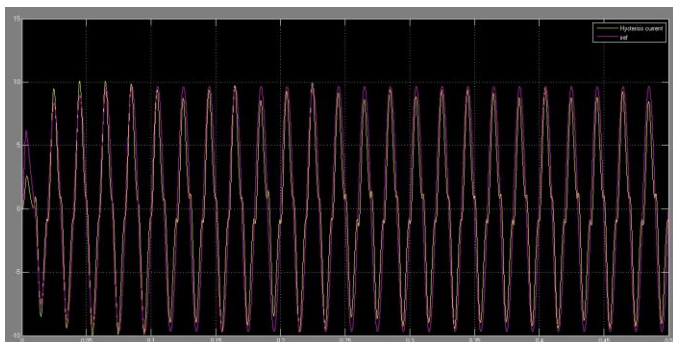

Fig-3. current comparison for hysteresis current and reference current at standard atmospheric condition.

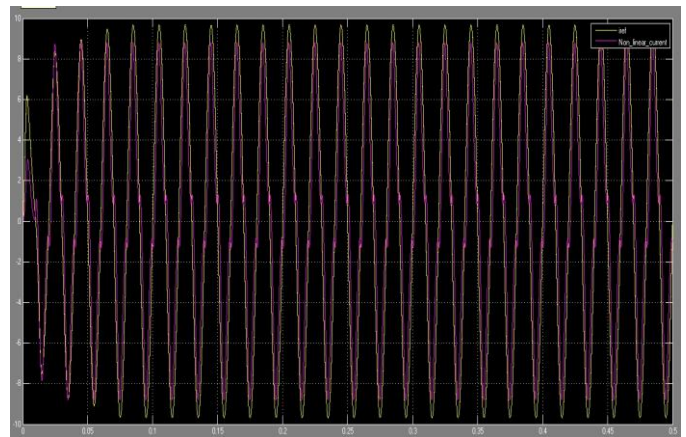

Fig-4. Current comparison for Nonlinear current and reference current at standard atmospheric condition.

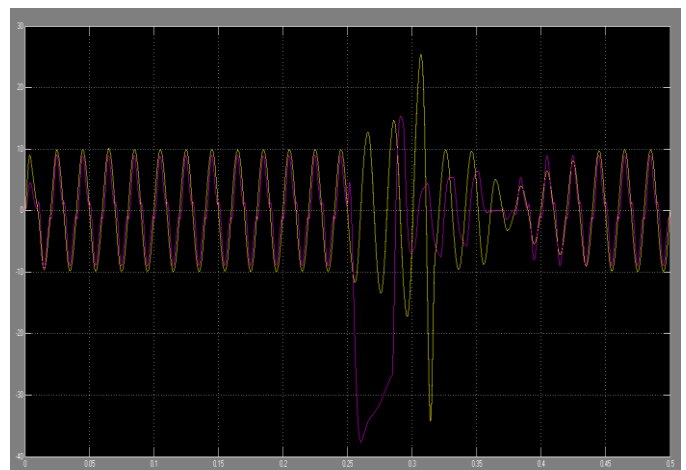

Fig- 5. Current Comparison of Hysteresis and Non Linear current controller during fault condition.

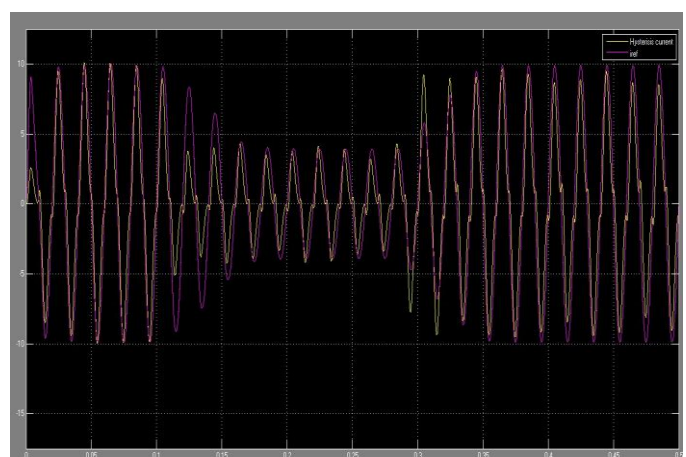
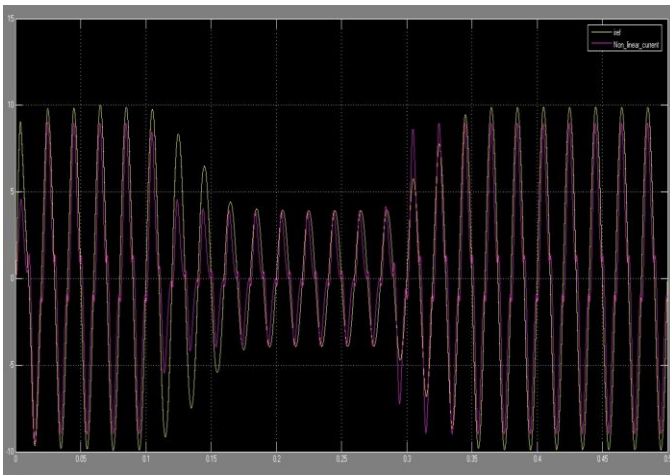

Fig- 6. Comparison of Hysteresis Current And Reference Current At Change In Atmospheric Condition.



**Fig- 7.** Comparison of Nonlinear Current And Reference Current At Change In Atmospheric Condition.

### 3. CONCLUSIONS

A partial feedback linearizing nonlinear current control scheme was presented to improve the dynamic performance of a single-phase grid-connected PV system with changes in atmospheric conditions, variations in load conditions, and faults on different parts of the system. All the possible nonlinearities are very well canceled by the proposed controller designed approach by transforming the PV system into a reduced order linear system with stable internal dynamics. The injected current into grid is controlled to ensure the operation of the PV system at the MPP. Future work will deal with the extension of the proposed method by considering some mismatches within the PV model and implementation on a laboratory-based system. A review on various current control techniques/schemes has been discussed here & it is found that nonlinear current control scheme, presented & validated using MATLAB simulation is more efficient compared to hysteresis current control and other controlling schemes under various conditions. The project work is supported with results obtained in MATLAB simulation through waveforms

### ACKNOWLEDGEMENT

I would like to express my deepest appreciation to all those who provided me the possibility to complete this paper. A special gratitude to my guide, Prof A. P. Chaudhari, whose contribution in stimulating suggestion and encouragement helped me to coordinate my project in effective way.

### REFERENCES

[1] M. A. Mahmud, H. R. Pota, and M. J. Hossain, "Nonlinear Current Control Scheme for a Single-Phase Grid-Connected Photovoltaic System" *IEEE TRANSACTIONS ON SUSTAINABLE ENERGY*, VOL. 5, NO. 1, JANUARY 2014.

[2] T. Kato, T. Inoue, and Y. Suzuoki, "Impact of Large-scale Penetration of Photovoltaic Power Generation Systems on Fluctuation Property of Electricity Load" 2010.

[3] I. Houssamo, F. Locment, and M. Sechilariu, "Maximum power point tracking for photovoltaic power system: Development and experimental comparison of two algorithms," *Renew. Energy*, vol. 35, no. 10, pp. 2381-2387, Oct. 2010.

[4] Casadei, G. Grandi, and C. Rossi, "Single-phase single-stage photovoltaic generation system based on a ripple correlation control maximum power point tracking," *IEEE Trans. Energy Convers.*, vol. 21, no. 2, pp. 562-568, Jun. 2006.

[5] Sreekanth G, Narender Reddy N, Durga Prasad A, Nagendrababu V "A Mppt Algorithm Based Pv System Connected To Single Phase Voltage Controlled Grid" *International Journal of Advancements in Research & Technology*, Volume 1, Issue 5, October-2012 1 ISSN 2278-7763.

[6] T. Esmar and P. L. Chapman, "Comparison of photovoltaic array maximum power point tracking techniques," *IEEE Trans. Energy Convers.*, vol. 22, no. 2, pp. 439-449, Jun. 2007.

[7] M. E. Ropp and S. Gonzalez, "Development of a MATLAB/Simulink model of a single-phase grid-connected photovoltaic system," *IEEE Trans. Energy Convers.*, vol. 24, no. 1, pp. 195-202, Mar. 2009.

[8] B. D. Subudhi and R. Pradhan, "A comparative study on maximum power point tracking techniques for photovoltaic power systems," *IEEE Trans. Sustain. Energy*, vol. 4, no. 1, pp. 89-98, Jan. 2013.

[9] Mattia Ricco, Patrizio Manganiello, Eric Monmasson, Giovanni Petrone, and Giovanni Spagnuolo, "FPGA-Based Implementation of Dual Kalman Filter for PV MPPT Applications" *IEEE Transactions on Industrial Informatics*, 2015.

[10] J. Selvaraj and N. A. Rahim, "Multilevel inverter for grid-connected PV system employing digital PI controller," *IEEE Trans. Ind. Electron.*, vol. 56, no. 1, pp. 149-158, Jan. 2009.

[11] P. P. Dash and M. Kazerani, "Dynamic modeling and performance analysis of a grid-connected current-source inverter-based photovoltaic system," *IEEE Trans. Sustain. Energy*, vol. 2, no. 4, pp. 443-450, Oct. 2011.

[12] N. A. Rahim, J. Selvaraj, and C. C. Krismadinata, "Hysteresis current control and sensorless MPPT for grid-connected photovoltaic systems," in *Proc. IEEE Int. Symp. Industrial Electronics*, Vigo, Spain, 2007, pp. 572-577.

[13] A. Kotsopoulos, J. L. Duarte, and M. A. M. Hendrix, "A predictive control scheme for DC voltage and AC current in grid-connected photovoltaic inverters with minimum DC link capacitance," in *Proc. 27th Annu. Conf. IEEE Industrial Electronics Society*, Colorado, USA, 2001, pp. 1994-1999.

[14] E. Bianconi, J. Calvente, R. Giral, E. Mamarelis, G. Petrone, A. Ramos-Paja, G. Spagnuolo, and M. Vitelli, "A fast current-based MPPT technique employing sliding mode control," *IEEE Trans. Ind. Electron.*, vol. 60, no. 3, pp. 1168-1178, Mar. 2013.

[15] T. L. Nguyen and K.-S. Low, "A global maximum power point tracking scheme employing DIRECT search

algorithm for photovoltaic systems," IEEE Trans. Ind. Electron., vol. 57, no. 10, pp. 3456–3467, Oct. 2010.

- [16] Arun Raj, Anu Gopinath " Proportional plus Integral (PI) Control for Maximum Power Point Tracking in Photovoltaic Systems" International Research Journal of Engineering and Technology (IRJET) Volume: 02 Issue: 06 | Sep-2015.
- [17] Aurel Botezan, Ioan Vadan and Silviu stefanescu "Hysteresis Current Control of the Single - Phase Active Filter" Annals of university of Craiova ,Electrical Engineering series, No 37,2013,ISSN 1842-4805.
- [18] K Smriti Rao, Ravi Mishra " Comparative study of P, PI and PID controller for speed control of VSI-fed induction motor" 2014 IJEDR | Volume 2, Issue 2 | ISSN: 2321-9939.