

Design and Implementation of Boolean Functions using Multiplexer and also using Shannon Expansion Theorem

Kumaresh Rout¹, Srilata Basu², Sarita Misra³

¹Professor, Dept. of Electrical & Electronics engineering, GITA College, Odisha, India

²Professor, Dept. of Electronics & Communication Engineering, GITA College, Odisha, India

³Professor, Dept. of Electrical & Electronics Engineering, GITA College, Odisha, India

Abstract - Implementation of Boolean function through multiplexer can be done by various multiplexers depending upon the select lines. Implementation of Boolean functions can be done by various methods, but in this particular paper stress is more on multiplexers. Through Shannon expansion theorem, it is easy for us to implement the Boolean functions in a simpler way. An electronic multiplexer makes it possible for several signals to share one device or resource, for example one A/D converter or one communication line, instead of having one device per input signal.

Keywords -

Multiplexers, 2 x 1, 4 x 1, 8 x 1, multiplexers, Shannon Theorem.

1. INTRODUCTION -

Digital electronics or digital (electronic) circuits are electronics that handle digital signals - discrete bands of analog levels - rather than by continuous ranges (as used in analogue electronics). All levels within a band of values represent the same numeric value. Because of this discretization, relatively small changes to the analog signal levels due to manufacturing tolerance, signal attenuation or parasitic noise do not leave the discrete envelope, and as a result are ignored by signal state sensing circuitry. Each logic symbol is represented by a different shape. The actual set of shapes was introduced in 1984 under IEEE/ANSI standard 91-1984. "The logic symbol given under this standard are being increasingly used now and have even started appearing in the literature published by manufacturers of digital integrated circuits."

1.1 Multiplexer -

The multiplexer, shortened to "MUX" or "MPX", is a combinational logic circuit designed to switch one of several input lines through to a single common output line by the application of a control signal. Multiplexers operate

like very fast acting multiple position rotary switches connecting or controlling multiple input lines called "channels" one at a time to the output.

Multiplexers or MUX's, can be either digital circuits made from high speed logic gates used to switch digital or binary data or they can be analogue types using transistors, MOSFET's or relays to switch one of the voltage or current inputs through to a single output.

1.2 Basic Multiplexing Switch -

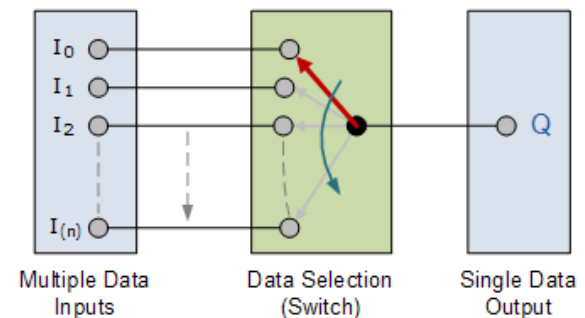

Fig - 1: Basic Multiplexing Switch

The most basic type of multiplexer device is that of a one-way rotary switch as shown above. The rotary switch, also called a wafer switch as each layer of the switch is known as a wafer, is a mechanical device whose input is selected by rotating a shaft. In other words, the rotary switch is a manual switch that you can use to select individual data or signal lines simply by turning its inputs "ON" or "OFF". So how can we select each data input automatically using a digital device.

In digital electronics, multiplexers are also known as data selectors because they can "select" each input line, are constructed from individual Analogue Switches encased in a single IC package as opposed to the "mechanical" type selectors such as normal conventional switches and relays. They are used as one method of reducing the number of

logic gates required in a circuit design or when a single data line or data bus is required to carry two or more different digital signals. For example, a single 8-channel multiplexer.

Generally, the selection of each input line in a multiplexer is controlled by an additional set of inputs called control lines and according to the binary condition of these control inputs, either "HIGH" or "LOW" the appropriate data input is connected directly to the output. Normally, a multiplexer has an even number of 2N data input lines and a number of "control" inputs that correspond with the number of data inputs.

2. 2-INPUT MULTIPLEXER DESIGN -

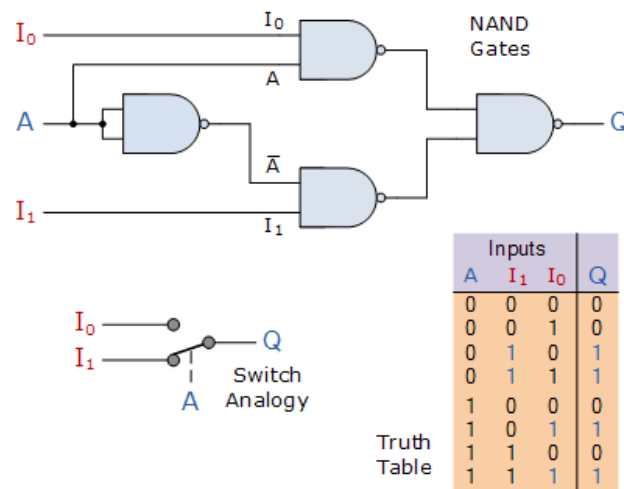

Fig - 2: Two-Input Multiplexer Design

The input A of this simple 2-1 line multiplexer circuit constructed from standard NAND gates acts to control which input (I₀ or I₁) gets passed to the output at Q. From the truth table above, we can see that when the data select input, A is LOW at logic 0, input I₁ passes its data through the NAND gate multiplexer circuit to the output, while input I₀ is blocked. When the data select A is HIGH at logic 1, the reverse happens and now input I₀ passes data to the output Q while input I₁ is blocked.

So by the application of either a logic "0" or a logic "1" at A we can select the appropriate input, I₀ or I₁ with the circuit acting a bit like a single pole double throw (SPDT) switch. Then in this simple example, the 2-input multiplexer connects one of two 1-bit sources

to a common output, producing a 2-to-1-line multiplexer and we can confirm this in the following Boolean expression.

$$Q = \bar{A}.I_0.I_1 + \bar{A}.I_0.\bar{I}_1 + A.I_0.\bar{I}_1 + A.I_0.I_1$$

And for our 2-input multiplexer circuit above, this can be simplified too:

$$Q = \bar{A}.I_1 + A.I_0$$

We can increase the number of data inputs to be selected further simply by following the same procedure and larger multiplexer circuits can be implemented using smaller 2-to-1 multiplexers as their basic building blocks. So for a 4-input multiplexer we would therefore require two data select lines as 4-inputs represents 2² data control lines give a circuit with four inputs, I₀, I₁, I₂, I₃ and two data select lines A and B as shown.

3. 4-TO-1 CHANNEL MULTIPLEXER -

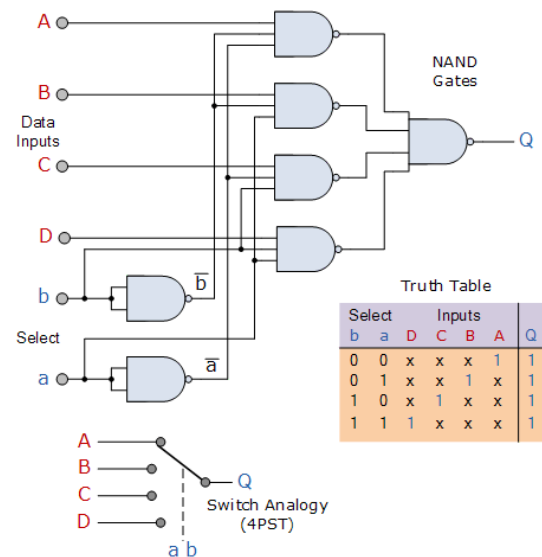

Fig -3: 4-to-1 Channel Multiplexer

The Boolean expression for this 4-to-1 Multiplexer above with inputs A to D and data select lines a, b is given as:

$$Q = \bar{a}\bar{b}A + \bar{a}bB + a\bar{b}C + abD$$

In this example at any one instant in time only ONE of the four analogue switches is closed, connecting only one of the input lines A to D to the single output at Q. As to which switch is closed depends upon the addressing input code on lines “a” and “b”, so for this example to select input B to the output at Q, the binary input address would need to be “a” = logic “1” and “b” = logic “0”.

Then we can show the selection of the data through the multiplexer as a function of the data select bits as shown.

4. MULTIPLEXER INPUT LINE SELECTION -

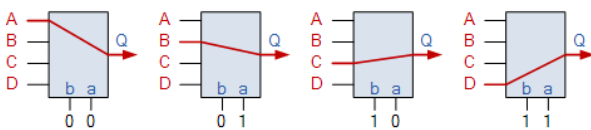

Fig - 4: Multiplexer input line selection

Adding more control address lines will allow the multiplexer to control more inputs but each control line configuration will connect only ONE input to the output.

5. BOOLEAN FUNCTION IMPLEMENTATION OF MULTIPLEXER -

$$n=2^m$$

n - number of input variables

m- number of select inputs

5.1 Using 8x1 multiplexer for implementation -

$$F (A1, A2, A3) = \sum (3, 5, 6, 7)$$

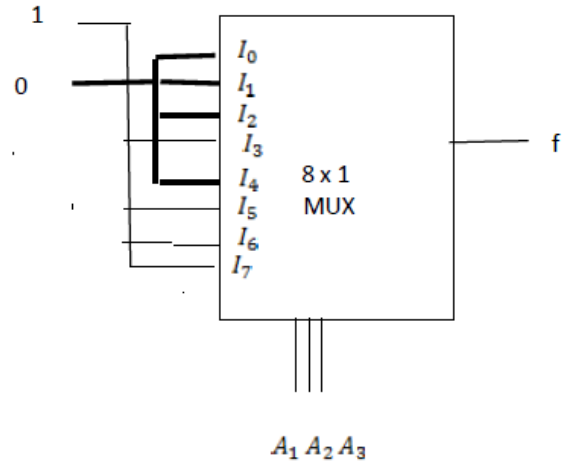

Fig - 5: 8x1 Multiplexer

5.2 Using 4x1 Multiplexer for implementation -

$$F (A1, A2, A3) = \sum (3, 5, 6, 7)$$

If MSB i.e. A1 is used as single variable, and A2, A3 as select inputs.

| Minterms | A ₁ | A ₂ | A ₃ | f |
|----------|----------------|----------------|----------------|---|
| 0 | 0 | 0 | 0 | 0 |
| 1 | 0 | 0 | 1 | 0 |
| 2 | 0 | 1 | 0 | 0 |
| 3 | 0 | 1 | 1 | 1 |
| 4 | 1 | 0 | 0 | 0 |
| 5 | 1 | 0 | 1 | 1 |
| 6 | 1 | 1 | 0 | 1 |
| 7 | 1 | 1 | 1 | 1 |

Fig - 6: Truth Table

| | I_0 | I_1 | I_2 | I_3 |
|-------------|-------|-------|-------|-------|
| \bar{A}_1 | 0 | 1 | 2 | 3 |
| A_1 | 4 | 5 | 6 | 7 |
| | 0 | A_1 | A_1 | 1 |

Fig - 7: Multiplexer Implementation

Function can be expressed as sum of products form
 $f = \bar{A}_1 A_2 A_3 + A_1 \bar{A}_2 A_3 + A_1 A_2 \bar{A}_3 + A_1 A_2 A_3$
 It can be manipulated into
 $f = \bar{A}_1 (A_2 A_3) + A_1 (\bar{A}_2 A_3 + A_2 \bar{A}_3 + A_2 A_3)$
 $= \bar{A}_1 (A_2 A_3) + A_1 (A_2 + A_3)$

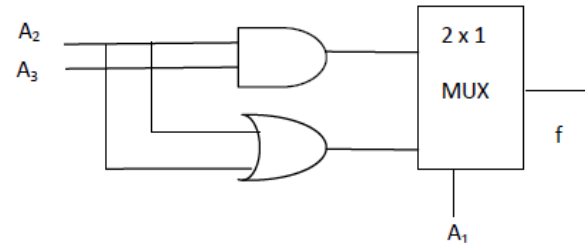

Fig - 9: 2x1 Multiplexer using Shannon Expansion Theorem

7. APPLICATIONS OF MULTIPLEXER -

Multiplexer circuits find numerous applications in digital systems. Some of the fields where multiplexing finds immense use are data selection, data routing, operation sequencing, parallel-to-serial conversion, waveform generation and logic function generation

Also a Multiplexer is used in various applications wherein multiple data can be transmitted using a single line. They are:

7.1 Communication System -

A Multiplexer is used in communication systems, which has a transmission system and also a communication network. A Multiplexer is used to increase the efficiency of the communication system by allowing the transmission of data, such as audio & video data from different channels via cables and single lines.

7.2 Computer Memory -

A Multiplexer is used in computer memory to keep up a vast amount of memory in the computers, and also to decrease the number of copper lines necessary to connect the memory to other parts of the computer.

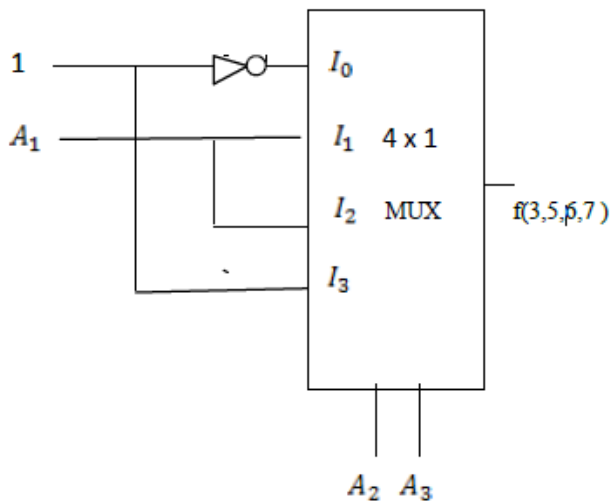

Fig - 8: 4x1 multiplexer implementation

6. SHANNON'S EXPANSION THEOREM -

Shannon's expansion or the Shannon decomposition is a method by which a Boolean function can be represented by the sum of two sub function of the original. Shannon expansion develops the idea that Boolean function can be reduced by means of the identity.

$$f = x f_x + \bar{x} f_{\bar{x}}$$

Where f is any function f_x and $f_{\bar{x}}$ are positive and negative Shannon cofactors of f respectively.

$$F(A_1, A_2, A_3) = \sum (3, 5, 6, 7)$$

7.3 Telephone Network –

A multiplexer is used in telephone networks to integrate the multiple audio signals on a single line of transmission.

7.4 Transmission from the Computer System of a Satellite –

A Multiplexer is used to transmit the data signals from the computer system of a satellite to the ground system by using a GSM communication.

8. CONCLUSION –

In this paper we have seen that Boolean functions can be implemented using different multiplexers, 2x1, 4x1 or 8x1. With the help of Shannon expansion theorem, complicated Boolean functions can be made easy, in implementing through multiplexers. This study will be very helpful for researchers and intellectuals to easy understanding and practicing of implementation of Boolean functions through multiplexers in the field of computer science and technology.

9. REFERENCES –

- [1] en.wikipedia.org/wiki/Multiplexer
- [2] [en.wikipedia.org/wiki/Shannon's expansion](http://en.wikipedia.org/wiki/Shannon's_expansion)
- [3] M. MORRIS MANO "Digital Logic and Computer Design" 2nd edition
- [4] John P. Uyemura "A First Course in Digital System Design: An Integrated Approach" India Edition