

Farmer friendly Solar Operated Spray Pump

Pritam J. Mali¹, Yogesh G. Ahir¹, Akash S. Bijagare¹, Rajendra S. khadayate^{2*}

¹T.Y.B.Sc. Physics students, ²Associate Professor in Physics

Department of Physics, G. D. M. Arts, K. R. N. Commerce and M. D. Science College, Jamner, Dist. Jalgaon, Maharashtra, INDIA

*Corresponding author email: rskhadayate@yahoo.com

Abstract - Energy is the basic need of human being. Human revealed the new path in sciences by using conventional energy sources and non-conventional energy sources. But most of the innovation depends upon conventional energy sources get affected on environment and human health in running days. We are interested to turn science into green science by using non-conventional sources. Basically sun is clean source of energy which is inexhaustible. Sun emits solar radiation by using solar panel we easily conduct electricity and do any mechanical work. Farmer is the heart of Indian Economy and our new invention gives support by making farmer friendly solar operated spray pump. Use of other pesticide pumps causes fatigues, pollution which is harmful for green society. Considering all energy crisis, solar energy would be one of the best solutions. Here we prepared low cost farmer friendly solar operated pesticide pump with devices such as emergency LED and dc mobile charger. This pesticide pump is remotely use at various places such as farm, garden also in municipality to kill mosquitoes. We hope our new invention make the farmers modern and smarter.

Key Words: Solar energy, green energy, solar panel, multipurpose machine, farmer friendly devices.

1. INTRODUCTION

“Energy - demand” is one of the major threads for our country. Finding solutions, to meet the “Energy demand” is the great challenge for Social Scientist, Engineers, Entrepreneurs and Industrialist of our Country. According to them, Applications of Non conventional energy is the only alternate solution for conventional energy demand. Now-a-day energy becomes very popular for all kinds of development activities [1-4]. One of the major area, which finds number of applications are in Agriculture Sectors [5].

Science and Engineering is making use of knowledge to meet human needs by creating machine, systems, process and technologies that have not previously existed. Design and manufacturing are the synthetic part of engineering practice. Manufacturer has received a lot of attention recently for very good economic reasons [5-12].

In Indian farms generally two types of spray pumps are used for spraying; hand operated spray pump and fuel operated spray pump. Of which hand operated spray pump is most popular. The main drawback of hand operated spray pump is that the user can't use it for more than 5-6 hours continuously as he gets tired after some hours where as fuel

operated spray pump requires fuel which is expensive and availability of fuel is not easy at rural places. At the same time it exhausts carbon dioxide as pollutant which is harmful to our environment. Also use of other pesticide pumps causes fatigues. In such situation we should think to move towards some non-conventional energy. Considering it, solar energy would be one of the solutions. Solar energy plays an important role in drying agriculture products and for irrigation purpose for pumping the well water in remote villages without electricity. This technology on solar energy can be extended for spraying pesticides, Fungicides and Fertilizers etc., using Solar Sprayers.

We know 70% of population of our country lives in villages and their main occupation is agriculture. Our prominent aim of this project is to fulfil the tasks like hand spraying, IC engine spraying, and leg pump spraying etc. using non-conventional energy sources.

Here we prepared a low cost solar operated pesticide pump with devices such as emergency LED, dc mobile charger, which can work without any fuel. This pesticide pump can be use at various places such as farm, garden also in municipality to kill mosquitoes. We hope our new invention make the farmer modern and smarter. In this project, we emphasized on the spraying of pesticides using solar power as energy.

2. Experimental

Fig.1 shows the schematic diagram of lab prepared solar operated spray pump. Fig.2 shows its block diagram. It consists of Tank, Battery section with a 12V dry battery, Pipe, Spray gun with ON-OFF switch, Solar panel, two adopters; one for mobile charger and other LED bulb.

Sprayer is mechanical device that are specifically designed to spray liquid quickly and easily. They have number of different varieties. In this project we prepared solar operated spray pump and which can be used for many purposes. Our solar based pesticide spray pump is one of the most improved and modern version spray pump. It can be most often used at various locations such as farms, gardens although it can become more popular in rural areas as well. It is found more reliable to use. It uses solar power to run so it is maintenance free and pollution free pesticide pump as compare to two stroke engine pumps. The additional advantage of this model is that, it can be useful for appliances like emergency LED and unique DC mobile charger; also it can be used as home lighting system as its battery can be used at night too.

Schematic diagram:

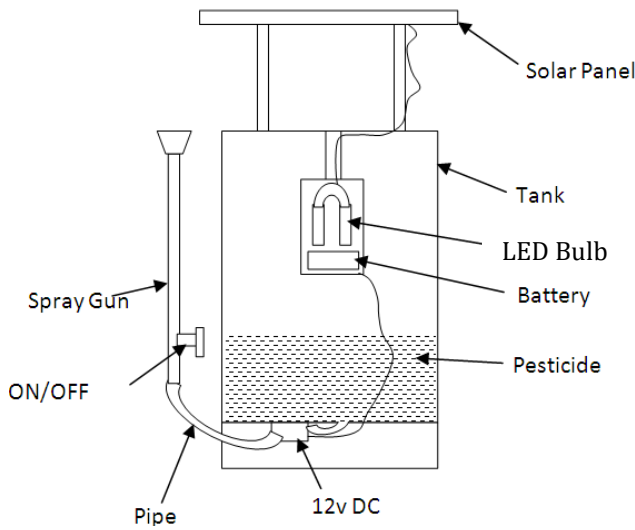

Fig-1: Schematic diagram of Solar operated spray pump

Block diagram of solar operated sprayer

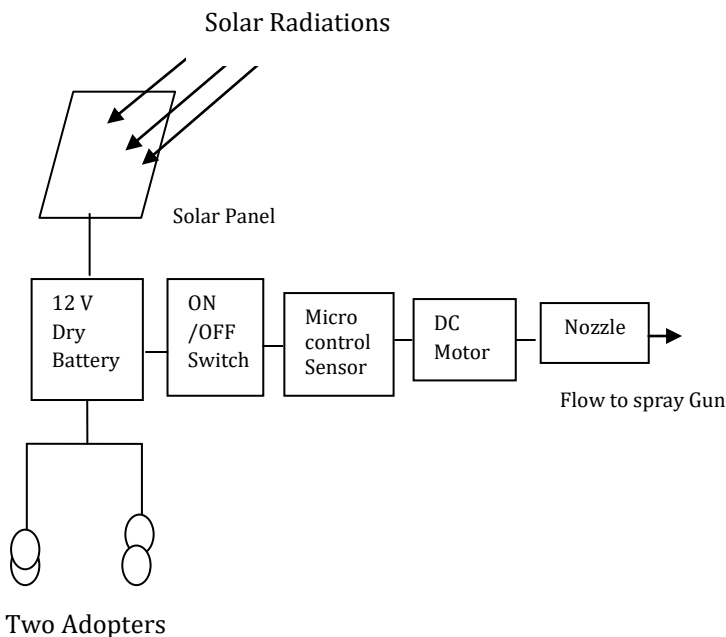

Fig -2: Block Diagram

Working:

The basic block diagram and circuit diagram are as shown in figure. The solar pump system consist of solar panel, DC motor, Battery, micro control sensor, emergency LED, DC mobile charger, spray nozzle, pesticide tank etc. It uses solar energy to operate. First the solar panel collects solar radiation and converts it into electrical energy by photovoltaic conversion process. Battery uses this electricity to charge itself. The stored electricity used to run the motor and other portable devices. When the switch is turn ON the

electricity is provided to motor to suck pesticide from tank and deliver it. But the ON and OFF state of motor is control by spray gun trigger. When trigger is pulled, the motor is made ON and pressure is maintained by micro control sensor. As trigger is released, the motor is made OFF. For portable devices, the adaptors are fixed on the body of tank. This adaptor provide plug-in and out connection for emergency LED, DC mobile charger.

Role of emergency LED and D.C. mobile charger:

The 12 v battery is charged with the help of solar panel. From 12 v battery two adaptors are fixed on the frame of the tank. This adaptor provides plug -in and out connectors for emergency LED and DC mobile charger. In presence of emergency LED and DC mobile charger farmer have portable option to fulfill his need.

Circuit Diagram:

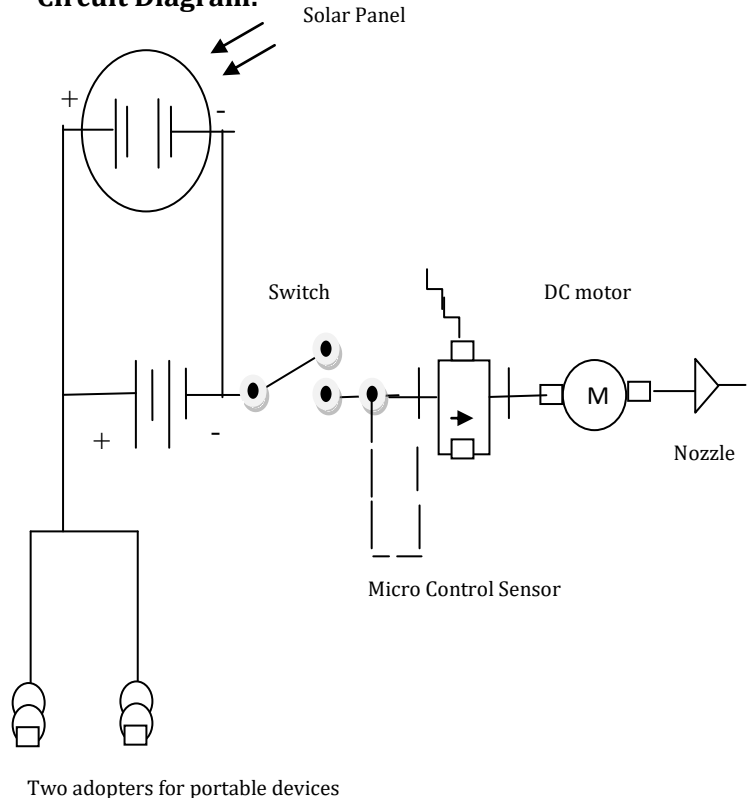

Fig -3: Circuit diagram

Technical specification of components:

- **Solar panel:**
Power – 10 watt
Size – 2*2.5
Weight of panel – 1.6 kg
- **Battery :**
O/p Power – 84 watt
Operating voltage – 12 V
Current – 7 amps.
Weight of battery – 2 kg
- **D.C Motor :**

Volt – 12 v
 Ampere – 2.1 amps
 Flow – 2.7 LPM
 Pressure – 80 PSI (5.5 bar)

• **D.C Mobile Charger :**

Input – 12 v
 Output - 3-4 v dc / 640 mA
 Connectivity - All cell phones (by five plug-in systems)

3. Results, Discussions and Conclusions

Fig.4. shows photos of lab built solar operated spray pump with facility of mobile charger and LED bulb. The solar panel is attached to spray pump in such a way that, it come exactly on the head of farmer, while spraying pesticides and it will protect the famer from direct sun rays heating. Based on experiments, it is found that charged solar pump sprays can used during day time between 9 AM to 5 PM. All the tests are successfully carried out at same time. Fully charged solar spray pump works for 7-8 hrs. Continuously and same time it will be charged. We also use both portable devices (LED and DC mobile charger) during working hours. Hence this modern model is more effective than any other spray pump. The model cost is Rs 3130/- and it is affordable for common farmer.

Detail cost chart:

DC motor	Rs. 350/-
12V dry Battery	Rs. 800/-
Solar panel	Rs. 1000/-
DC charger	Rs. 120/-
Micro control sensor	Rs. 400/-
Tank structure (from scrap)	Rs.150/-
LED	Rs. 70/-
Spray gun & nozzles	Rs. 240/-

Total cost-	Rs.3130/-

Table-1:Comparison of our modern model with available models in the market:

Parameter	Solar operated pump	Engine operated pump	
		Petrol	Diesel
Working	Battery powered pump	Two stroke	Two stroke
Weight	6.8 kg + water	7.6 kg + water	8.5 kg + water
Initial cost	Rs 3130/-	Rs 6500/-	Rs 6200/-
Maintenance	Free	Needed	Needed
Operating cost	Nearly zero	Rs 70-75 per hrs.	Rs 55-60 per hrs.
Effect on environment and Noise	Pollution free and No noise	Pollutes air and Large noise	Pollutes air and Large noise



Fig.-4: Photos of Solar operated spray pump

4. Conclusions:

- 1.The prepared solar operated spray pump is environment friendly and cost efficient.
- 2.Our modern solar spray pump system is most suitable conventional energy devices.
- 3.We have given the best option to farmer who economically challenged and facing electrical problem like load shading now days.
4. The prepared solar operated spray pump can be used largely in agriculture field very effectively.
5. It does not create air pollution and noise.
6. It does not require fuel hence zero fuel machine.
7. It can use in municipality for killing insects and mosquitoes.
8. It is maintenance free device.
9. It includes emergency LED and DC mobile charger; make this pump more farmers friendly.
- 10.It is easy to operate and portable.

Thus solar operated spray pump will help the farmers of those remote areas of country where fuel is not available easily. They can perform their regular work as well as saves fuel up to large extent. At the same time they can do their pesticide spraying work with very less environment pollution. Thus, indirectly saving revenue of government and also most demanded fuel.

5. Scope for the future work:

The total model weight is 21 kg with fully pesticide tank. The weight can be reduced 2-3 kg by using plastic molding for mechanical structure. Further energy can be saved by using PWM Scheme for driving pump.

ACKNOWLEDGEMENT

Authors are thankful to Principal and members of local management committee of G.D.M. Arts, K.R.N. Commerce and M.D. Science College, Jamner, Dist-Jalgaon, Maharashtra, INDIA, for their encouragement and necessary support.

REFERENCES

- [1] Solar energy utilization, G.D.Rai, Khanna Publishers, Delhi, 1996.
- [2] Nonconventional energy sources, G.D.Rai, Khanna Publishers, Delhi, 2000.
- [3] Solar Energy, S.P.Sukhatme,, (Tata MacGraw Hill).
- [4]Fundamental of Solar cell, M.A.Green.
- [5]Solar Sprayer - An Agriculture Implement, R. Joshua, V. Vasu and P. Vincent, International Journal of Sustainable Agriculture 2 (1): 2010, pp16-19.
- [6] Solar Sprayer-An Agriculture Implement, R. Joshua, V. Vasu andP.Vincent, International Journal of Sustainable Agriculture,2 (1), 2010, pp 16-19.
- [7]Multiple Power Supplied Fertilizer Sprayer,V. V. Rao, S. Mathapati and B. Amarapur, International Journal of Scientific and Research Publications,3 (8), 2013, pp 1-5.
- [8]Unique Solar Operated Spray Jet, Z. Khan, IOSR Journal of Mechanical and Civil Engineering (IOSR-JMCE) ,2014, pp 43-46.
- [9]Solar Powered sprayer for agriculture uses, S.P. Yadav, P. M. Kakkad and A. V. Bhujade, International Journal of Research In Science and Engineering, Volume: 1 Issue: 3
- [10]Solar operated pesticide sprayer , P. Lad et. all, International Journal of Advance Research In Science And Engineering, IJARSE, Vol. No.4, Special Issue (01), 2015,pp123-126.
- [11] Multiple Power Supplied Fertilizer Sprayer, M.S. Sarswat et.all,International journal of innovations in Engineering Research and Technology, 2(2) , 2015, pp 1-6.
- [12] Solar Operated Multiple Granulated Pesticide Duster, A. Jivrag, V. Chawre and A. Bhagwat, Proceedings of the World Congress on Engineering vol 3, 2011

BIOGRAPHIES



Pritam J. Mali
T.Y.B.Sc. Physics student 2015-16
Keen interest in solar devices for green environment



Yogesh G. Ahir
T.Y.B.Sc. Physics student 2015-16
Keen interest in green environment



Yogesh G. Ahir
T.Y.B.Sc. Physics student 2015-16
Keen interest in using modern devices in farming



Dr. Rajendra S. khadayate
Associate Professor in Physics
Department of Physics
G. D. M. Arts, K. R. N. Commerce and
M. D. Science College, Jamner, Dist,
Jalgaon, Maharashtra, INDIA
Research Area: Gas sensor, Solar cell
(Project guide of above three students)