

BUS TRACKING AND TRANSPORTATION SAFETY USING INTERNET OF THINGS.

Prof.Priti Shende, Pratik Bhosale, Shahnawaz Khan, Prashant Patil.

*Dr. D. Y. Patil Institute of Engineering and Technology, Pimpri, Pune -411018
Department of Electronics & Telecommunication Engineering*

-----***-----
Abstract - *Internet of Things (IoT) refers to uniquely identifiable objects and their representation in an Internet-like structure. The term, IoT although coined way back in 1999, became popular after the onset of RFIDs. There are estimates of more than 30 billion devices being wirelessly connected to the Internet of Things by 2020. The existing research work on IoT has been immense and has been carried out in various fields like smart home systems, retail/supply chain management, insurance and healthcare. Also the field of IoT has its own challenges and drawbacks which need to be overcome to realize its full potential. The purpose of our research is to understand the feasibility of implementing Internet of Things in bus transportation system in Singapore. Singapore, which is renowned for its technology advancements, still has scope for improvement in terms of technology being used for transportation purposes. There is a dire need for the consumer to understand and evaluate different bus options in an efficient manner and this is where Internet of Things infrastructure can help. Our secondary research has helped us structure a technical architecture in place for an app where Internet of Things can be used to predict arrival timings of buses as well as the crowd inside each bus. Also, the primary research helped us gain immense knowledge in the field of IoT and helped us with the protocols for communication between the devices in our architecture which is the part where most IoT deployments tend to fail. Finally, we could conclude that such an implementation is possible and also there is a lot of future scope for it to be built upon when the world realizes how to overcome the current limitations of IoT.*

Key Words: Internet of Things (IOT),RFID

1. INTRODUCTION

In India, there is a need for proper bus transport system. With increase in the population it has led to uncertain crowding at public bus stops. People wait for long hours and suddenly gather near stops whenever they see any bus coming by, even though it is not their destinations bus. This leads to unnecessary crowding which be solved by the use of this smart design of IOT based bus transport system.

Here in our project, we aim to reduce the crowd at public places and where in people will come to know about the

upcoming buses which have left the previous stop and are heading to the next stop soon. So by applying this approach a person need not to gather to see which bus is coming their way. He may sit and relax until his bus arrives from the previous stop. By using this designed system we can come to know about all the buses that are heading towards the bus stop, their destination and the time they will require to reach the stop. By using IOT a person at remote place i.e. away from stop or anywhere at home or workplace can know the information about the bus, from which stop, at what time, within how much time the bus will reach destination and much more information about it through the internet. The user will need to just open his web browser, enter the static IP address. And then the whole information related to the bus can be accessed by him.

In India, until now we do not have such a smart city bus transport system where in the real time of the bus reaching the destination is known. Further implementations can be made in this project like we can also display the no. of vacant seats in the bus, so if there is a limited seated bus, people in the queue will get the place and the remaining will have to wait for the next bus to come. This will lead to a safe and comfortable journey indeed reduce the crowding.

2. PROBLEM STATEMENT

India, there is a need of proper bus transportation system. With increase in the population it had led to uncertain crowding at public bus stops. People wait for long hours and suddenly gather near stops whenever they see any bus coming nearby, even though it is not their destinations bus. This leads to unnecessary crowding which can be solved by the use of this smart design of IOT based bus transport system.

Also the real time data with respect to the travelling bus is not available with the main bus stops. They only have the approximate time details of the arrival time of the bus and the reaching time at destination. so the system is forced to work under assumptions. There is no certainty in the information regarding bus. If it comes on time, then it is ok, but if it does not comes on time the station controller gives false statements that it will be there in 5 minutes or 10 minutes, in spite of the fact that he doesn't even know where the bus is. Whether it is struck in traffic or any break down has occurred etc. So by using this system we can have

information about the bus on the internet. What we need to do is just put the IP address of the bus on the web page of the browser. All the data related to the bus can be seen in real time like where the bus is, the temperature of the area from where the bus passes by, live footage inside the bus through CCTV cameras, monitor the exact speed and the time required by the bus to reach the destination. This all things are required in the smart city which will be seen by the year of 2020

In order to prove this concept we will be showing how the data is transferred from the microcontroller to the Ethernet module and how it gets clouded to the server. We will be having a Local area network created, and by entering the static IP we can see the next destination of the bus, final destination of the bus or the route it is following to reach destination, temperature of the places travelled by bus.

The other things mentioned in the goals of the project can be implemented in the similar way. But for the sake of proving the concept and considering cost constrains, we will be showing its two or three applications only.

3. LITERATURE SURVEY

Before the start of the Project we had conducted the following survey on different things. They are as follows:

a) Compared the transportation systems of the foreign countries with India:

In the developed countries, the transportation ease and safety is much more improved and cost efficient with respect to their standards and way of living.

They have less population and more resources so there is no crowding and therefore people are able to follow the rules and discipline accordingly. Even the bus stops are very much clean and hygienic; some are air conditioned in places like Dubai. In India, there is no transportation safety as people have the tendency to run towards the bus as they see the bus coming nearby.

The physically fit and strong people somehow make it to get place but the old people and ladies are left on the stop.

This shows that there is no discipline or kind of rules people are supposed to follow.

Being the most populated country, it has more number of people travelling and less resources leading to crowding.

By studying the above points, we came to the conclusion that we need to devise such a system which can at least reduce the crowing at bus stops.

Neither we can control the population nor we can increase the number of bus services. We can implement such a system through which people can come to know which bus is about to come on the bus stop.

b) Visited the major bus stops to know the problems faced by people and the transport faculties:

We had visited many city bus stops in our area. We found that the transportation system was not much user friendly.

There is no safety of people in transportation. People are habituated to stand in the doors of the bus and travel which is much dangerous and can cause a serious damage to lives. People do not know the exact time of the bus neither bus times are not fix. Sometimes come on the time and sometimes even delayed by an hour.

There is no bus tracking system implemented by the government, so that the exact location of the bus can be traced.

The problems faced by the transport faculties are due to much crowd in the bus the ticket conductor is not able to collect the charges of transportation and some people travel free of cost.

If some accident occurs and some break down occurs in bus, they do not get proper help in time.

By considering the above problems, we need to improve the safety standards by implementing such a system through which people can come to know about the upcoming bus on the bus stop.

Also people can come to know about the information regarding buses by just accessing internet from anywhere.



Fig 3.1. Unnassary crowding at bus stop.

c) Why the Indian transport system is much lagging than the transport system of other countries?

In the developed countries the concept of IOT is already been implemented .The major factor in the implementation is the availability of Internet.

In India, people are tending to use Internet less frequently than that of other countries. The facilities of internet are much more expensive in India than in comparison with other countries.

As the cost of internet is much high we cannot afford to implement and connect each and every thing with IOT.

Government need to provide the facilities of Internet for transport in fewer expanses so that it can be brought into implementation.

The users are more while services are less.The rules and regulations with respect to safety are not strictly followed.



Fig 3.2. Unsafe transportation in Cities.

d) Public Transport in India:

The Present Scenario

The conventional Bus is relatively a more convenient, speedier and cheaper means of passenger transport in providing economical, adequate and well coordinated rural transport network. While this bonanza service, so named after its vital role cited above, is provided by both the State Transport Undertakings and the private operators, the objectives of these two operators are convergent on certain aspects and divergent on certain others. Accordingly, private operators in India, as everywhere, choose to operate bus services on profitable routes, leaving out the unprofitable ones. The STUs, on the other hand, are operating bus services to various villages subject to the availability of motorable roads, either on their own initiative or on being directed to do so by the State Governments concerned. Here it may be mentioned that the STUs are caught between two divergent corporate objectives — of plying the services on commercial considerations on the one hand and social considerations on the other. There is, however, a need for reasonably reconciling these two objectives, lest the STUs should cease to operate on uneconomical routes thereby depriving the rural masses access to various goods, services and facilities. The reconciliation becomes possible only if the Central and State Governments realise that the STUs, by taking up bus services in villages, are only discharging a social obligation which, strictly speaking, is one of the constitutional responsibilities.

e) State Road Transport Undertakings (SRTUs):

The Public Bus Transport in India is mainly operated by State Road Transport Undertakings (SRTUs) — created under Section 3 of the Road Transport Corporations (RTC) Act 1950, and private operators.

A few points are significant in the case of State Road Transport Undertakings (SRTUs). The objective of the RTC Act of 1950 is to promote an efficient, adequate, economic and properly coordinated system of public road transport service in the country, to protect the workmen and their family by providing financial and social security, and to create infrastructure for bus depots, bus stands, workshops, training institutes etc.

At present, 55 SRTUs are operating nearly 1, 47,000 buses. This includes 37 corporations, 10 municipal bodies and eight government organizations. These SRTUs operate about 8 million kms per day and provide gainful employment to 7 lakh employees.

f) Public bus transport operated by private sector:

There are another six lakh buses which are being operated by private operators in the country. In addition to this, people in many villages are forced to travel by unauthorized modes of transport such as s, animal carts, three-wheelers, etc, which are unsafe.

At present India has a very less bus penetration, i.e., 1.29 buses per population of 1000 as against 2.93 of United Kingdom, 2.77 of USA, 1.83 of Japan, 1.35 of France, 10.03 of Brazil, 6.50 of South Africa, 3.14 of Mexico, 2.37 of Malaysia and 1.84 of China.

4. BLOCK DIAGRAM

Bus Transmitter module:

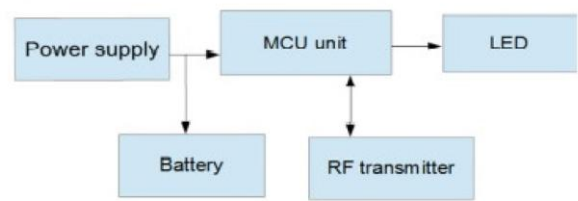

Receiver module:

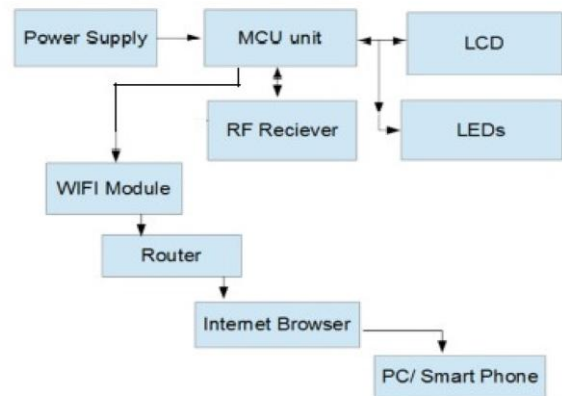

Fig4.1. Block diagram of transmitter & receiver.

5. WORKING PRINCIPLE

There are two sections in our project one is transmitter section which is placed on bus and another section is receiver section placed on bus stop. Bus is consistently sending a message through RF module. When bus comes in the range of the bus stop, bus stop receives the message which indicates that bus arrives from the bus stop. Then bus stop updates the current location via Ethernet module. This modifies the current location of the bus on the website of BMS(Bus Management Board). This website consisting of a

local IP address configured to the router. So citizens can have the actual bus location tracking through the internet, which is provided by entering the IP address in the internet browser. Simultaneously the bus station sends message to the next successive bus station informing about upcoming bus on the stop. The next successive stop will be display as the received message on LCD.

6. RESERCH METHOD USED IN IOT PAPERS

-I project has run a survey in 2010 to identify the different IoT application scenarios in different domains. This survey was based on 270 responses from 31 countries and it identified smart home and smart city as the most attractive scenarios. (Smith, 2012). Another survey was conducted addressed to top executives representing retailers and manufacturers of European FMCG companies. In addition, a consumer survey was done to get useful input regarding the innovative retails consumer services (Sundmaeker, Guillemin, Freiss, & Woelfflé, 2010). A survey was also carried out to examine the possible application layer protocols for sensor networks (Akyildiz, Su, Sankarasubramaniam, & Cayirci, 2002). In January 2009, a team of researchers in China studied Internet routing data to understand the growth of connected devices to the internet (Evans, 2011).The recognition of the power of data by business was studied in a recent survey of over 600 global business leaders (Gobble, 2013). To study the impact of strategic applications of IoT, a survey was conducted to determine what impact they would make (Carrez, 2012).These research papers suggest a need for a public survey to understand the passenger side for a particular IoT implementation. Also there is a need for a qualitative survey to understand the feasibility of implementing IoT in a certain area.

7. CHALLENGES AND DRAWBACKS OF IOT

One of the main challenges for the Internet of Things is in transformation of the connected objects into the real time sensing actors which also involves the societal and ethical considerations. IOT technologies enable or control the capabilities of the people and how this influences people's capabilities to satisfy accountability demands. The multiple dimensions of accountability such as visibility, responsibility, control transparency and predictability should be taken into consideration to be controlled with the capacities of IOT technologies. Internet of things is spreading widely in the present world which accounts for at least two objects connected per person (Boos, Gunter, & Kinder, 2012). It is expected that by 2015 an average person would be accompanied by seven objects. The key challenge that sparks for this innovation is protection of privacy. Three very important barriers that exist for IoT development are having a single standard, the development and transition to the newer IPv6 and developing energy

sources for the huge number of sensors (Evans, 2011). Another challenge in building IOT is lack of common software fabric and how to combine all the software systems in building the common software platform (Internet and privacy concerns, 2012). The first direct challenge for this is that the generation of huge scale of data may even have digital twin in cloud that could be generating regular updates as a result of which the messaging volume could easily reach between 100 to 10000 per person.

8. CONCLUSION

By implementing this idea, we can improve the transportation safety and the quality of services to the Public in rural and urban cities of India.

REFERENCES

- [1] *"Internet of Things Global Standards Initiative"*. ITU. Retrieved 26 June 2015.
- [2] https://hbr.org/resources/pdfs/comm/verizon/18980_HBR_Verizon_IoT_Nov_14.pdf
- [3] http://www.internet-of-things-research.eu/pdf/Converging_Technologies_for_Smart_Environments_and_Integrated_Ecosystems_IERC_Book_Open_Access_2013.pdf
- [4] http://www.cisco.com/web/solutions/trends/iot/introduction_to_IoT_november.pdf
- [5] <http://cordis.europa.eu/fp7/ict/enet/documents/publications/iot-between-the-internet-revolution.pdf>

BIOGRAPHIES



Prof. Priti Shende, Working as an Assistant Professor at E&TC Department in Dr. D.Y. Patil Institute of Engineering and Technology, Pimpri from 27-11-2001. Total Teaching experience of 15 years in same institute. Total 4 paper published, 2 international and 2 national. Attended several workshops.



Pratik Bhosale, born in 1994, in Maharashtra, India. Pursuing BE in Electronics and Telecommunication Engineering from Dr. D.Y. Patil Institute of Engineering and Technology, Pimpri. His areas of interest are Embedded systems, Fiber optic communication, mobile communication & computer networks.



Shah Nawaz Khan, born in 1994, in Maharashtra, India. Pursuing BE in Electronics and Telecommunication Engineering from Dr. D.Y. Patil Institute of Engineering and Technology, Pimpri. His areas of interest are Embedded systems, Fiber optic communication, mobile communication & computer networks.



Prashant Patil, born in 1994, in Maharashtra, India. Pursuing BE in Electronics and Telecommunication Engineering from Dr. D.Y. Patil Institute of Engineering and Technology, Pimpri. His areas of interest are Embedded systems, Fiber optic communication, mobile communication & computer networks.