

# Selection of Passive Component for Cockroft Walton Voltage Multiplier: A Low Cost Technique

Chitra Sharma<sup>1</sup>, A. K. Jhala<sup>2</sup>, Manish Prajapati<sup>3</sup>

<sup>1</sup> M. Tech Scholar, Dept. of Electrical Engineering, RKDF-College of Engineering, Bhopal, India

<sup>2</sup> Associate Professor, Dept. of Electrical Engineering, RKDF-College of Engineering, Bhopal, India

<sup>3</sup> Assistant Professor, Dept. of Electrical Engineering, RKDF-College of Engineering, Bhopal, India

\*\*\*

**Abstract** – *This paper describes the selection of component at design level. In this paper various criteria is explained in brief to achieve the design parameter. As High Voltage DC (HVDC) transmission is becoming more popular in the present scenario of bulk power transmission over long distance transmission, it is required to study the testing of various insulation materials at laboratory level in under graduate and post graduate course curricula. Since, generation and handling of high voltage is very dangerous and required skilled personnel in the laboratory. In addition, it is very much costly. If any institute or educational organizations wish to install high voltage laboratory in their premise they need huge investment including the civil structure. Apart from the basic requirement, a precise development of electrical circuit is required in order to generate high voltage in the laboratory.*

**Key Words:** *Cockroft Walton Voltage Multiplier, High Voltage, educational Laboratory, Low Cost Circuit.*

## 1. INTRODUCTION

Quite a few researchers are active in the field of high voltage engineering. It is noteworthy that the system for generation of high voltage for educational laboratories for the study of high voltage phenomena is very challenging task. In order to achieve the same one need well developed laboratories with all safety precaution as per the rules. Various methods and techniques has been developed to achieve high rated voltage to study the phenomena of high voltage testing and measurement. Obviously, playing with high voltage engineering is fascinating for everyone. Very first, N. Tesla had successfully experimented various high voltage technique to reduce the loss of transmission even for the longer distance. High voltage is becoming integrated part of electrical power system along with x-ray generation, medical advancement and other field [1]. In year 1930 J. D. Cockroft and E.T.S. Walton had proposed circuitry for generation for high voltage using Grienercher Voltage Doublers circuit for the study of high voltage generation for positive ion emission

from the hydrogen and other element [2]. In their successive submission they had presented the application of Cockroft Walton Voltage Multiplier (CWVM). Insulation testing of cable, disc insulator and other electrical insulator draws heavy current if they are tested under the high voltage AC. In [3] author had detailed the advantages of CWVM for the small and handy device so that the cost and weights are minimized. In the same work author presented a paper for the optimal utilization of the dynamic performance of the circuit. However, rating of such device depends on the breakdown strength of the material.

A wide application of DC high voltage and their methods of generations are discussed by the various authors [1, 4, 15, 19]. In this work, author had got the attention of research community towards the best utilization of high voltage engineering. In addition, the various limitations for the study of high voltage engineering came to light. However, this work is again a proportional of the high investments to be made for the development of laboratories and to keep it functional all the time. BHEL (Bharat Heavy Electrical Limited), IISc (Indian Institute of Science, Bangalore), JEC (Jabalpur Engineering College), and other CFTI (Centrally Funded Technical Institutes) have functional and well developed laboratories. Nonetheless, some of the institutes provide consultancy on high voltage testing for the recovery of revenue as well as for further extension of laboratory. However, this limitation is overcome by the [8] to reduce the cost for generation of high voltage in the laboratory. In this work, author had presented an active and functional model of generation of high voltage using CWVM up to 60 [kV] in the educational laboratory. An extension of work is mentioned in [27] which rated up to 110 [kV] to generate the functional level of the multiplier. In this paper, authors had achieved a minimization of ripple of voltage at earlier stages with common capacitor rating. Also, no load behavior is discussed in both [8, 27]. However, there is no clear explanation of selection of capacitor and the diode (passive and active component respectively)

In this paper a criteria for the selection of parameter and device rating has been discussed. Although, for the clear selection of the number of stages depends on the test level voltage requirement. In laboratory high level of generation can be made using the multiple converters. Yet, the rating

may be limited up to 1000 [kV] for successful study of various phenomena.

This paper is divided as follows, in section-II fundamental and known working is presented. Section-III describes the selection of various elements; section-IV compares the simulation results between the usual selection and proposed selection scheme. At section-V conclusion is presented.

### 2. Operating Principle.

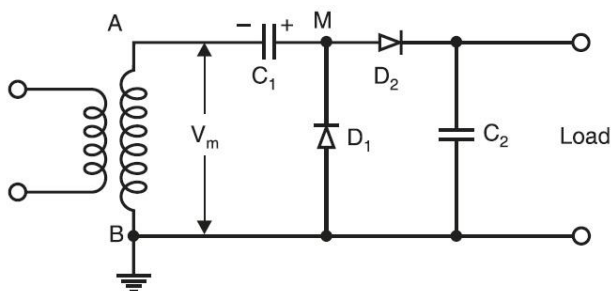

Fig. :- 1 Grienacher Voltage Doubler Circuit [1, 4, 5, 27]

Fig-1 shows the well known device structure for the voltage doubler which is used to double the input voltage at terminal A-B. It is well known the performance of half wave rectifier bridge for the generation of pulsating DC. But after point M it gets doubled at load end.

### 3. Selection Criteria.

This section describes the various criteria for the selection of various element including the number of stages for the desired output level. In addition, required limit of ripple in output voltage is considered to minimize the selection of capacitor size.

#### 3.1 Selection of Number of Stages.

Here [8] and [27] presented a strict number of stages for the CWVM circuit once the system is assembled it is not possible to dismantled the system to get a lower voltage level. Then selection of stages needs to be in accordance with the required output voltage and the total drop till the final stage.

$$n = \frac{V_{out} + V_{drop}}{2 * V_{Peak}} \quad (1)$$

In the above equation if the value comes a fraction then the nearest greater integer is considered for the selection.

#### 3.2 Selection of Capacitor

Generally, capacitor is selected based on ripple content in the output voltage. In order to minimize the ripple one need to define the voltage level at the various

ripple content. Hence it is important to consider the output level either we are considering at final stage or any intermediate stage. In this work only final stage ripple is considered, to minimize the ripple at final stage a way to achieve it is to minimize it at earlier level.

Mathematically, capacitor size is given as for a specific ripple level is,

$$2\delta V = q \sum_{n=2}^{2n} \frac{1}{C_n} \quad (2)$$

$$q = \frac{I}{f} \quad (3)$$

For a specific cases in [8,27] a equal magnitude of capacitor has been selected to avoid the complexity of the multiplier.

Ripple for final output stage is given by equation (4) in this equation frequency of operation is same as that of supply frequency while the output ripple is considered as the some fixed percentile of the output voltage.

$$2\delta V = q \left( \frac{1}{C_{2n}} + \frac{2}{C_{2n-2}} + \frac{3}{C_{2n-4}} + \frac{4}{C_{2n-6}} + \dots + \frac{n}{C_2} \right) \dots (4)$$

In this case supply frequency is considered as 50 [Hz]. To minimize the final stage voltage ripple one can minimize the intermediate stage. A detailed optimal technique will be presented in future work.

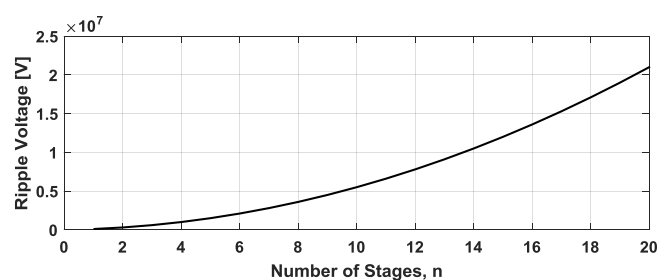

Fig. :- 2 Variation of Ripple Voltage at Different Stages

In fig 3 it is very much clear that at higher stages ripple is much higher. This figure is important for investigation of stage where the higher Capacitor can be installed to achieve the minimum ripple at final stage.

Generally, equal capacitance causes a non linear characteristic of ripple most commonly a quadratic function as at each level voltage ripple get doubled. While, in the non equivalent condition ripple characteristic may become less quadratic.

### 3.3 Selection of Diode.

Diode at each level performs two major operations as firstly, it conducts to discharge the every capacitor at each level and secondly it blocks the reverse voltage to prevent the unwanted conduction. Generally, series-parallel combinations are used to maximize the level blocking voltage. But number of diode for each level is determined by its Peak-Inverse-Voltage.

It is advisable to select diode according to [27] as *smoothing and Oscillating* column. In this view, both columns will block a different voltage level to get the output at different level.

### 4. Simulation Results.

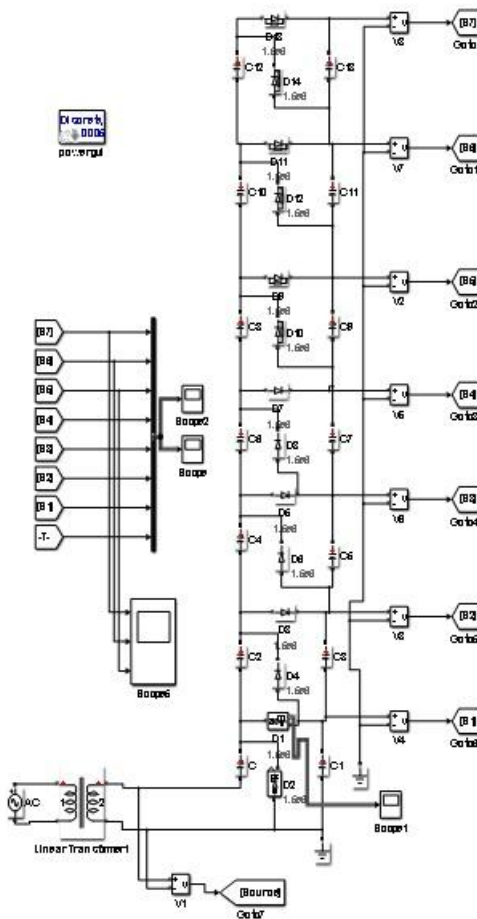

Fig. :- 3 Simulation Setup

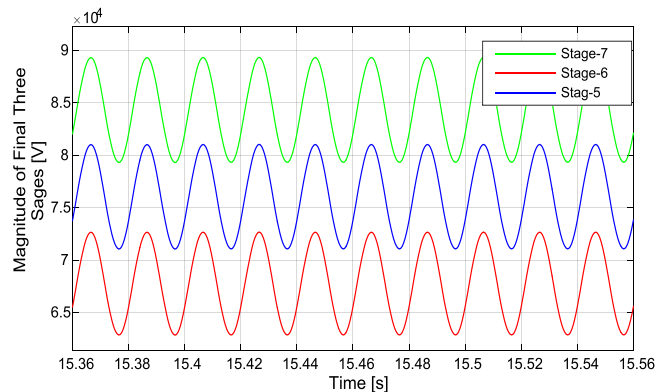

Fig. :- 4 Variation of Ripple Voltage at Different Stages

Table I Parameter Value for Simulation

Parameter	Numerical Value [unit SI]
Input Voltage to Primary of X'mer $V_p$	230[V]
Secondary Voltage	10000 [V]
Supply Frequency, $f$	50 [Hz]
Capacitor, $C$	100 [nF]
Number of Stages, $n$	7

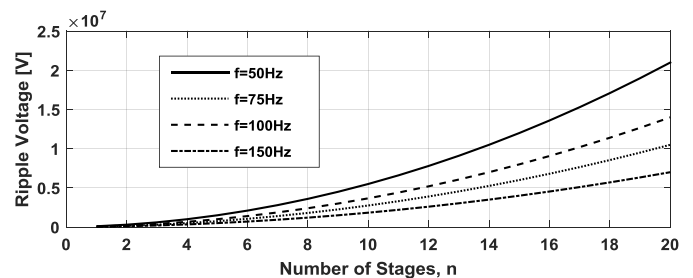

Fig. :- 5 Variation of Ripple Voltage at Different Stages and frequency

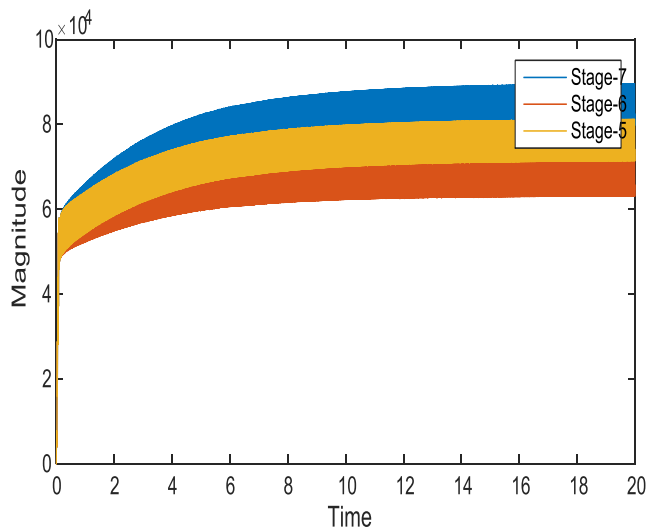

Fig. :- 6 Variation of Ripple Voltage at Different Stages and frequency

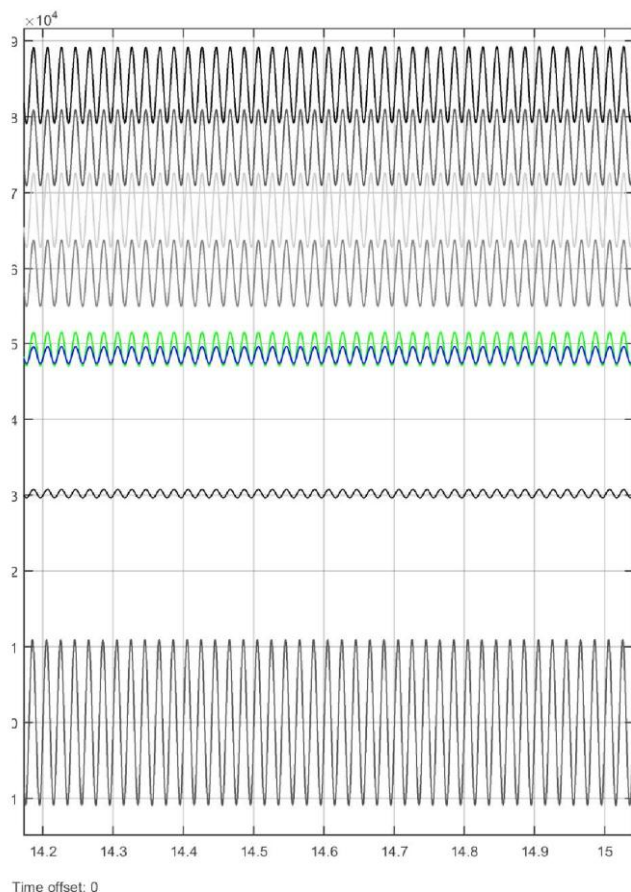

Fig. :- 7 Variation of Voltage at Different Stages with source

## 5. CONCLUSIONS

This paper ideates the selection of device on the bases of the performance of the multiplier. It is noteworthy that for higher level of multiplier circuit selection of component becomes important issue to deal with. Generation of High Voltage at laboratory up-to 100kV is designed and simulated for laboratory level. In this work effect of diode drops and parasitic resistance of capacitor is considered. Basically, selection of capacitor and its rating is main part of concern. compares the result between the usual selection

## ACKNOWLEDGEMENT

This work is part of Master thesis, under the guidance of A. K. Jhala and Manish Prajapati, at RKDF College of Engineering Bhopal, affiliated to RGPV, Bhopal.

## REFERENCES

- [1] Kuffel, E. and M. Abdullah, 1984. High Voltage Engineering. Pergamon Press, Oxford.
- [2] J. D. Cockroft and E. T. S. Walton, "Experiments with High Velocity Positive Ions," *Proceeding of Royal Society of London, Series A, Containing Papers of a Mathematical and Physical Character*, vol. 129, no. 811, pp. 477-489, 1930.
- [3] Spencer, D.F., R. Aryaeinejad and E.L. Reber. "Using the Cockroft-Walton Voltage Multiplier Design in Handheld Devices." *Idaho National Engineering and Environmental Laboratory*, P.O. Box 1625, Idaho Falls, ID 83415
- [4] Khan, N., 2004. Lectures on Art and Science of High Voltage Engineering. Published in Pakistan
- [5] Mazen, A.S. and R. Radwan, 2000. High Voltage Engineering Theory and Practice. Sec. Edn. Revised and Expanded, Marcel Dekker, Inc. Am. J. Applied Sci., 3 (12): 2178-2183, 2006 2183
- [6] Aintablian, H.O. and H.W. Hill, 1994. A new single phase AC to DC harmonic reduction converter based on the voltage-doubler circuit. Department of Electrical and Computer Engineering, Ohio University, Athens, IEEE.
- [7] John, C.S., 1993. Circuit topologies for single phase voltage - doublers Boost rectifiers. IEEE Trans. Power Elect., 8: 4.
- [8] Dwivedi, C. K., and M. B. Daigvane. "Multi-purpose low cost DC high voltage generator (60kV output), using Cockcroft-Walton voltage multiplier circuit." *Emerging Trends in Engineering and Technology (ICETET), 2010 3rd International Conference on*. IEEE, 2010.
- [9] 10. Yamamoto, I., K. Matsui and F. Ueda, 2000. A power factor correction with voltage doubler rectifier. Chubu University, Dep. Electrical Eng. Japan, IEEE.
- [10] Zhang, M., N.L. Iaser and F. Devos. An optimized design of an improved voltage Tripler. IEF, AXIS, University of Paris, 91405 Orsay, France.
- [11] Zhang, M., N. Liaser and F. Devos, 2002. Experimental results of an optimized voltage Tripler. IEF, AXIS, University of Paris, 91405 Orsay, France.
- [12] J.S.Burgler, "Theoretical performance of voltage multiplier circuits" IEEE.Journal of solid state circuits publications, vol.6,issue3, pp132-135, June 1971.
- [13] D. Maksimovic, S. Cuk, "Switching Converters with Wide DC Conversion Range", IEEE Transactions on Power Electronics, Vol. 6, No. 1, pp. 151-157, January 1991.
- [14] F. L. Luo, H. Ye, "Positive Output Super-Lift Converters", IEEE Transactions on Power Electronics, Vol. 18, No. 1, pp. 105-113, January 2003.

- [15] K. C. Tseng, T. J. Liang, "Novel high-efficiency step-up converter", *IEE Proc.-Electr. Power Appl.*, Vol 151, No. 2, pp. 182-190, March 2004.
- [16] C. Y. Inaba, Y. Konishi, M. Nakaoka, "High-frequency flybacktype soft-switching PWM DC-DC power converter with energy recovery transformer and auxiliary passive lossless snubbers", *IEE Proc.-Electr. Power Appl.*, Vol. 151, No. 1, pp. 32-37, January 2004.
- [17] F. Hwang, Y. Shen, S. H. Jayaram, "Low-Ripple Compact High Voltage DC Power Supply", *IEEE Transactions on Industry Applications*, Vol. 42, No. 5, pp. 1139-1145, Sept./Oct. 2006.
- [18] A. Shenkman, Y. Berkovich, B. Axelrod, "Novel AC-DC and DCDC Converters with a Diode-Capacitor Multiplier", *IEEE Transactions on Aerospace and Electronic Systems*, Vol. 40, No. 4, pp. 1286-1293, October 2004.
- [19] K. Ogura, E. Chu, M. Ishitobi, M. Nakamura, M. Nakaoka, "Inductor Snubber-Assisted Series Resonant ZCS-PFM High Frequency Inverter Link DC-DC Converter with Voltage Multiplier", *Power Conversion Conference (PCC'2002), Osaka (Japan)*, 2-5 April, 2002, Vol. 1, pp. 110 – 114.
- [20] "Experiment 19: Blaze Labs Resonant Multipliers", *Blaze Labs Research*, 12 September 2005, Internet paper, available: <http://www.blazelabs.com/e-exp19.asp>, accessed on 30/11/2006.
- [21] M.M. Weiner, "Analysis of Cockcroft-Walton Voltage Multipliers with an Arbitrary Number of Stages", *The Review of Scientific Instruments*, Vol. 2, No. 2, pp. 330-333, February 1969.
- [22] "Experiment 15: Cockcroft-Walton Multiplier", *Blaze Labs Research*, 30 August 2005, Internet paper, available: <http://www.blazelabs.com/e-exp15.asp>, accessed on 02/11/2015.
- [23] M. Julian, "Cockcroft-Walton Optimum Design Guide v2.0", 10 August 2005, Internet paper, available: <http://www.blazelabs.com/CWdesign.pdf>, accessed on 02/11/2015.
- [24] M. Khalifa, "High-Voltage Engineering, Theory and Practice", Chapter 16, *Electrical Engineering and Electronics, A series of Reference Books and Textbooks*, No.63, Marcel Decker Inc., March 1990.
- [25] Waluyo, Syahrial, Sigit Nugraha, And Yudhi Permana, "Miniature Prototype Design And Implementation Of Modified Multiplier Circuit Dc High Voltage Generator," *International Journal of Electrical Engineering and Technology (IJEET)*, vol. 6, no. 1, pp. 01-12, January 2015.
- [26] High Voltage Generation by using Cockcroft-Walton Multiplier," *International Journal of Science, Engineering and Technology Research (IJSETR)*, Volume 4, Issue 2, February 2015, vol. 4, no. 2, pp. 256-259, February 2015
- [27] Sharma, Chitra, A. K. Jhala, and Manish Prajapati. "Low Cost High Voltage Generation: A Technique For Educational Laboratory."

## BIOGRAPHIES



**Chitra Sharma**, Completed her bachelor of Engineering in Electrical & Electronics Engineering, in year 2012, from Chhattisgarh Swami Vivekananda Technical University. Currently she is pursuing her Masters of Technology in Power System and Control from RKDF College of Engineering, affiliated to RGPV. Her area of interest is Testing-Commissioning of Electrical Equipments, High Voltage Engineering, Power System and Apparatus, and Renewable Energy sources.



**A. K. Jhala**, Associate Professor, Did his B.E.(Electrical Engineering),2003 (Govt. Engineering college Rewa) RGPV (REC.REWA,M.P.)M.E. (Power Electronics), 2009 (LNCT Bhopal) RGPV Presently he is head of department Electrical Engineering at RKDF College of Engineering Bhopal.



**Manish Prajapati, Asst. Professor**, Did his BE(Electrical & Electronics Engineering) in year 2007, and ME(Power System) in year 2011 from RGPV, Bhopal. Presently he is faculty of electrical engineering at RKDF, College of Engineering Bhopal.