

Comparison between Analog and Digital Implementation of Maximum Power Point Tracking Techniques in Solar Photovoltaic Applications

B. Kailash Krishna Prasad¹, K. Prahlada Reddy²

¹Assistant Professor, Department of EEE, BITS-Kurnool

²Assistant Professor, Department of EEE, GPCET-Kurnool

Abstract – This paper mainly focuses on differentiating the implementation of Maximum Power Point Tracking techniques in both analog and digital modes. Digitally tracking the optimum point is the most widely used technique for achieving the better accurate results and also to accelerate the computation process to the maximum possible extent. But as far as cost particulars and complexity issues are concerned, analog tracking method of finding maximum power point is turned out to be the better alternative way. This paper distinguishes clearly about the adaptability of aforementioned methods by simulating in MATLAB/SIMULINK platform.

Key Words: Analog tracking, Complexity issues, Digital tracking, Maximum Power Point Tracking, Optimum Point.

1. INTRODUCTION

The Maximum Power Point Tracking (MPPT) is considered to be an essential process in tracking the optimal point of Photovoltaic (PV) array. Hence, many MPPT methods have already been developed and implemented in the literature [1] to describe the importance of finding the maximum power point (MPP). But the domain of implementing the MPPT technique holds the key issue which mainly describes about the complexity of the implementation, type of sensors to be employed, fastness of obtaining result, economic feasibility of method and other related aspects. Thus, selecting the mode of implementation of MPPT should become the highest priority for any researcher.

In general, there exist two modes of implementation of MPPT method i.e., in analog domain and digital domain of implementation. Efforts are put forth in this manuscript to distinguish clearly about both the modes of implementation and this paper serves as a convenient reference for further works in PV array based power generation systems.

1.1 Analog MPPT methods:

According to literature, many researchers have already tried to implement the analog based MPPT techniques to demonstrate its feasibility and easiness in developing [2-4]. The major advantage of this method is that, it requires less cost to implement and the circuit complexity also reduces

considerably. But if accuracy and fast computation results are needed, then this method may not yield satisfactory results.

G.Petrone *et.al* [5], explained clearly about the concept of implementation of analog based Distributed MPPT method. According to authors in [5], a module dedicated MPPT algorithm is required. But to implement this module dedicated MPPT algorithm in digital mode, high cost and sophisticated hardware equipment is required. Hence in [5], selection of analog method has been justified and demonstrated. This shows that, analog MPPT method is specifically meant for low cost design.

According to authors in [6], for rapidly changing conditions, a digital MPPT based method cannot be adapted easily to operation. The authors in [6] recommended utilizing radiation-hardened microcontrollers along with sophisticated MPPT algorithms in Digital mode of operation which enhances the complexity of the system further. Hence, usage of analog MPPT based methods is more useful in space craft applications.

Analog methods are having certain drawbacks and are discussed in further sections of this paper.

1.2 Digital MPPT methods:

Digital MPPT methods on the other hand, are the most widely used technique when compared to analog MPPT methods. The most popular digital MPPT methods implemented so far are Perturb & Observe (P&O) method, Fractional Short circuit (Isc) method, Incremental Conductance (InC) method, Fuzzy logic and Neural Network based MPPT method and so on. These methods are implemented either in Digital Signal Processing (DSP) or in Field Programmable Graphics Array (FPGA) platforms.

According to authors in [7], the Fuzzy logic based MPPT method is having overall good performance under varying atmospheric conditions, provided a better technical knowledge of rule-based table implementation is required. The authors in [7] have implemented a Digital based MPPT method i.e., InC method stating that it is easier to implement in DSP environment. Thus, if performance of the system should be improved and for obtaining faster response, then one has to opt for digital MPPT based methods.

The authors in [8] explained that, a fast dynamic convergence speed and a steady-state tracking efficiency can be achieved by adaptive-perturbation-frequency digital MPPT method. Thus, digital MPPT methods are employed to improve the steady state performance.

2. COMPARISON ASPECTS:

It is of utmost importance to choose appropriate MPPT technique to obtain satisfactory output. Solar photovoltaic systems are highly nonlinear in nature and tend to change very rapidly according to different atmospheric conditions. Hence, selection of MPPT method and its implementation is a vital function in PV array systems. Table-I gives an idea about the various MPPT methods and their implementation aspects. One of the analog methods available i.e., Ripple Correlation Control (RCC) method is not having facility to tune periodically [1]. On the other hand Fractional Open circuit Voltage (Voc) and Fractional Short circuit (Isc) methods are not considered to be true MPPT methods. In this paper, a comparison of implementation modes has been done by considering an analog method and a digital MPPT method called Incremental conductance (InC) method [7] which was simulated in MATLAB/SIMULINK. The existing MPPT methods are selected for simplicity reasons. The simulation results are discussed in further section. The various aspects like speed, convergence, complexity, tuning etc are mentioned in table-1.

Table -1: Comparison of popular Analog and Digital MPPT's

MPPT Methods				
MPPT method	Analog / Digital implementation	Speed	Complexity	Periodic Tuning
Perturb & Observe Method	Implemented both in analog and digital modes	Cannot be determined accurately since it varies a lot	Low	Not possible
Incremental Conductance Method	Implemented only in digital mode	Cannot be determined accurately since it varies a lot	Medium	Not possible
Fractional Open Circuit (Voc) Method	Both modes	Medium variation	Low	Possible
Fractional short Circuit (Isc) Method	Both modes	Medium variation	Medium	Possible
Ripple Correlation Method (RCC) Method	Analog only	Fast converging	Low	Not possible
Fuzzy Logic control and Neural Network	Digital only	Fast converging	High	Possible

3. BLOCK DIAGRAM OF ANALOG MPPT:

The block diagram of Analog MPPT method is represented in Fig -1. It is considered to be a simple method. The output of PV array i.e., voltage and current are tapped and given to a multiplier so that power is calculated. The power and voltage are given to an differentiator and further given as input to a comparator. The comparator compares both the inputs and the output of comparator is given to X-OR gate. The output of X-OR gate is given to SR Flip flop which generates a desired duty ratio and is given as a gate signal to DC-DC converter. For simulation purpose, buck converter is selected for simple analysis of circuit. Scaling circuit is required if this analog MPPT method is implemented in hardware further.

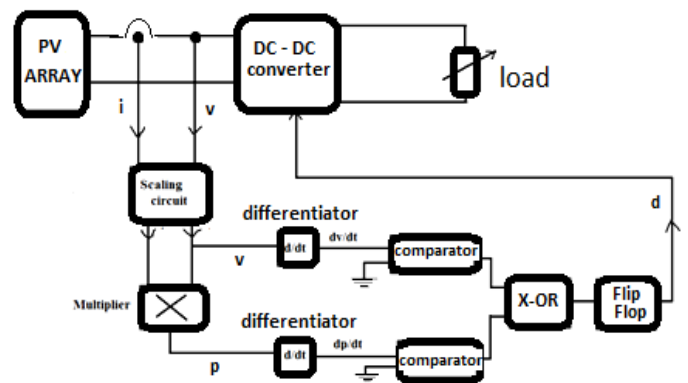

Fig -1: Block diagram of Analog MPPT

Thus, the output of the DC-DC converter can be varied by changing the duty ratio which is given to gate terminal of the converter Switch.

4. BLOCK DIAGRAM OF DIGITAL MPPT:

The block diagram of Digital MPPT method is represented in Fig -2.

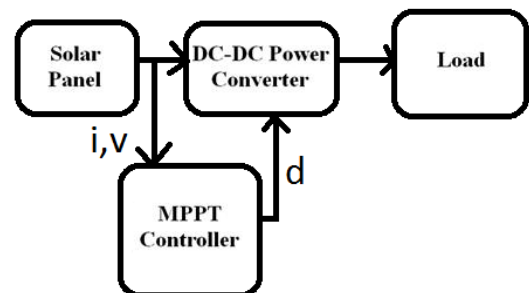

Fig -2: Block diagram of Digital MPPT

The digital MPPT is implemented in MATLAB/SIMULINK with the help of InC method as it more popular method. The duty ratio is generated by InC algorithm. The buck converter is selected here also for examining the results in comparison with analog MPPT. Both the MPPT methods are simulated by using Buck converter.

5. SIMULATION RESULTS:

5.1 Simulation results of Analog MPPT:

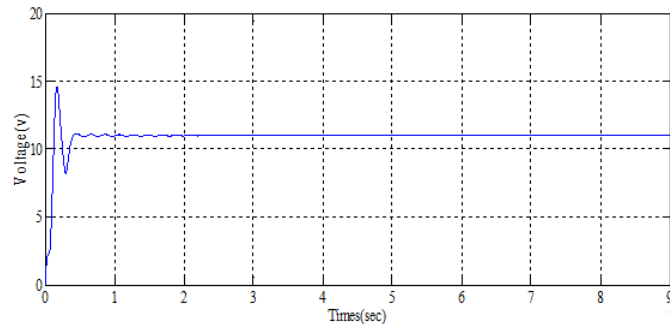

Fig -3: Output voltage of Buck converter by Analog MPPT

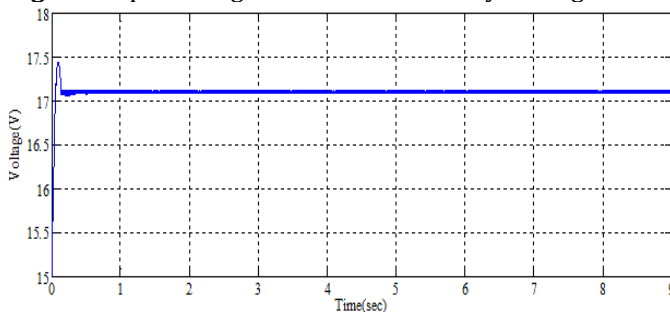

Fig -4: Input voltage at MPP at Irradiation $G=1000 \text{ Watt/m}^2$

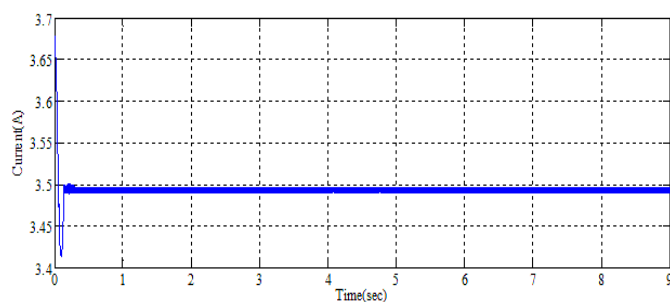

Fig -5: Input Current at MPP at Irradiation $G=1000 \text{ Watt/m}^2$

5.2 Simulation results of Digital MPPT:

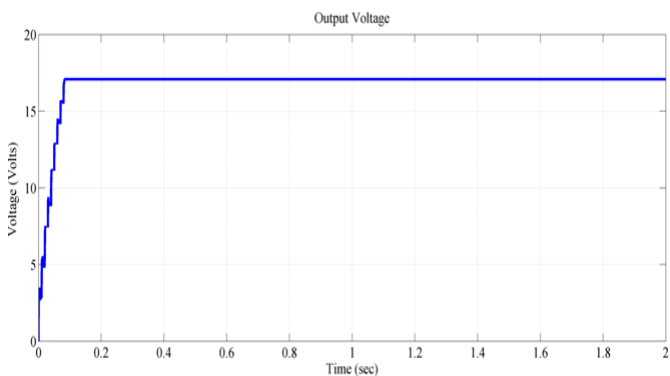

Fig -6: Output voltage of Buck converter by Digital MPPT

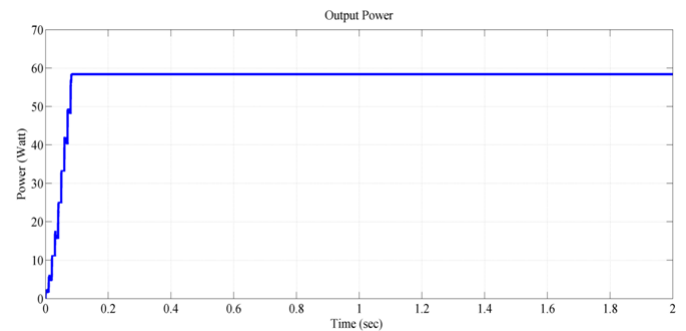

Fig -7: Output power of Buck converter by Digital MPPT

6. CONCLUSION:

The outlook of this paper is to explain about the different implementation methods of MPPT especially analog and digital MPPT methods. After observing the output voltage waveforms in both analog and digital MPPT methods, it can be clearly observed that, the waveform of analog method is having few transients where as the waveform of digital is tracking well without any transients. This shows that, digital MPPT method is having good performance when compared to analog MPPT method. And also, the convergence speed of digital MPPT is better than analog MPPT which is clearly observed in Fig -3 and Fig - 6. Thus, only cost point of view and hardware complexity view point, analog method is better choice and in performance view point digital method is better choice.

REFERENCES

- [1] T. Eswam and P. L. Chapman, "Comparison of Photovoltaic array maximum power point tracking Techniques," IEEE Transactions of Energy Conversion, Vol -22, No. 2, pp.439-449, DOI: 10.1109/TEC.2006.874230.
- [2] Ali Hmidet, Rabiaa Gammoudi, Othman Hasnaoui and Rachid Dhifaoui, "Analog MPPT Controller Circuit used in Photovoltaic Pumping Systems", The fifth International Renewable Energy Congress IREC -2014, March 25-27, Hammamet, TUNISIA.
- [3] Chih-Yu Yang, Chun-Yu Hsieh, Fu-Kuei Feng, and Ke-Horng Chen, "Highly Efficient Analog Maximum Power Point Tracking (AMPPT) in a Photovoltaic System", IEEE Transactions on Circuits and Systems—I: REGULAR PAPERS, Vol. 59, No. 7, July 2012, DOI: 10.1109/TCSI.2011.2177008.
- [4] Yi-Hua Liu, Zong-Zhen Yang, Shun-Chung Wang and Jia-Wei Huang, "A novel analog MPPT technique for low power photovoltaic systems", TENCON 2011, DOI:10.1109/TENCON.2011.6129227.
- [5] Giovanni Petrone, Giovanni Spagnuolo and Massimo Vitelli, "An Analog Technique for Distributed MPPT PV Applications", IEEE Transactions on Industrial Electronics, Vol. 59, NO. 12, December 2012, DOI: 10.1109/TIE.2011.2177613.
- [6] David Selcan, Gregor Kirbis and Iztok Kramberger, "Analog Maximum Power Point Tracking for Spacecraft Within a Low Earth Orbit", IEEE Transactions on Aerospace and Electronic Systems Vol. 52, No. 1 February 2016, DOI: 10.1109/TAES.2015.140279

- [7] Azadeh Safari and Saad Mekhilef, "Simulation and Hardware Implementation of Incremental Conductance MPPT With Direct Control Method Using Cuk Converter", IEEE Transactions on Industrial Electronics, Vol. 58, No. 4, April 2011. DOI:10.1109/TIE.2010.2048834
- [8] Yuncong Jiang, Jaber A. Abu Qahouq and Tim A. Haskew, "Adaptive Step Size with Adaptive-Perturbation-Frequency Digital MPPT Controller for a Single-Sensor Photovoltaic Solar System", IEEE Transactions on Power Electronics, Vol. 28, No. 7, July 2013. DOI: 10.1109/TPEL.2012.2220158

BIOGRAPHIES



B.Kailash Krishna Prasad received his M.Tech Degree from National Institute of Technology, Trichy, Tamil Nadu in the year 2010. He is currently working as Assistant Professor in Brindavan Institute of Technology and Science, Kurnool. His areas of research interest include Power electronic circuit analysis, Modeling and analysis of photovoltaic power systems and Energy audit. He is the life time member of ISTE chapter.



K. Prahlada Reddy received his M.Tech Degree from Vidya Vikas Institute of Technology (Affiliated to JNTU, Hyderabad). He worked as Assistant Professor and has a total teaching experience of about 6 years. His areas of research interest include Power electronics.