

# Failure investigation of Indigenized Boat under Carriage and Improvement in Frame Design

Anil Kumar<sup>1</sup>, Shivkumarappa<sup>2</sup>

<sup>1</sup> Asst. Manager, R&D Defence, Bangalore Complex, BEML Ltd, Bangalore, India

<sup>2</sup>Asst. General Manager, R&D Defence, Bangalore Complex, BEML Ltd, Bangalore, India

\*\*\*

**Abstract** - Boat under carriage is special equipment used for lurching and recovering the Boat from the river shore. It works on gravity principle for launching the Boat into waters. The retrieving of the Boat has been carried out by winch of HDT 8X8 vehicle. Boat under carriage is also used for transport the Boat across the terrain. The Under carriage consists critical parts such as Tilting frame, Travel truck and Other structural assemblies which are prone to malfunction of the Equipment if proper transport, manufacturing and operational pre-cautions not taken. It is also challenging to find out the reason for malfunction of the Equipment. In this paper, Failure investigation of the Boat under carriage has been carried out by Root Cause Analysis (RCA)/Failure Mode and Effects Analysis (FMEA) and solution given by FE analysis of Tilting frame structure for Smooth operation of Equipment.

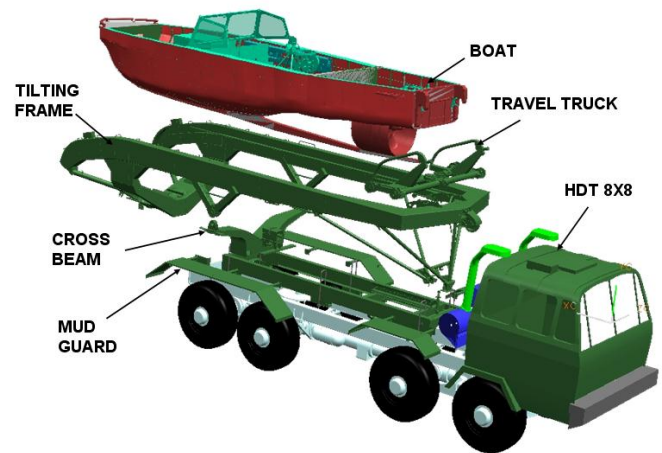
**Key Words:** Boat under carriage, FEA, RCA/FMEA, Tilting-Frame, Travel Truck.

## 1. INTRODUCTION

The Boat Under carriage is basically Tilt-able equipment used for the transport, launching and retrieval of the Boat. It is towed by Heavy duty 8x8 truck and the retrieval is carried out by the winch cable of the towing truck.

The Under carriage consists of the following main functional assemblies:

1. Base Frame
2. Tilting Frame
3. Travel Truck
4. Carrying axle and suspension
5. Brake system



**Fig - 1:** Exploded view of Boat under carriage

The Basic Frame consists of two longitudinal steel beams of rectangular section, connected by reinforcing cross members. The supporting axle assembly with suspension is fitted at the rear of the basic frame. The basic frame also has the handbrake mechanism, the auxiliary wheel, and the pulleys for guiding the cable(s) of the towing vehicle.

The tilting frame consists of two longitudinal members formed from thin plates into trapezoidal (in the front) section and closed C (E) section, with a reinforcing transverse beam in a deep 'V' shape to accommodate the boat hull. Rails fitted on the tilting frame longitudinal members to form the path on which the travel truck moves.

The main bearings for the tilting frame are located above the axle. This supports the tilting frame, which carries the travel truck, moving on rails within the tilting frame, that supports the boat during launching / retrieval operations. The tilting frame is also pivoted on the main bearings on the basic frame, and is locked by means of the moving and fixed arrestments provided on the basic frame.

The travel truck's main function is to support and guide the boat during launching and retrieval operations. It consists of two parallel tubular members, connected by closed beams. The travel truck is further guided by roller chains fitted alongside the rails, which serve to maintain the alignment of the travel truck with respect to the tilting frame axes.

The supporting axle is fitted with twin wheels along expanding shoe brakes acting on brake drums and actuated by pneumatically (service brakes) or mechanically (hand parking brakes). The axle is fixed to the chassis through leaf springs on each side.

## 2. METHODOLOGY

### 2.1 Root Cause Analysis

The complete boat launcher has over 1900 items and a component level RCA/FMEA was not practical. So, a system level Root cause analysis was proposed and initiated to find out failure of the launcher. The major sub-systems in the Boat under carriage are the Footing Frame, Tilting frame, Travel Truck, Axle Assy. and Suspension and Brake system.

Considering the methodology of usage, comparison with the imported equipment and involvement of the sub-system during the actual launching operations, brake system, footing frame, axle assy. and suspension were for the time being removed from consideration.

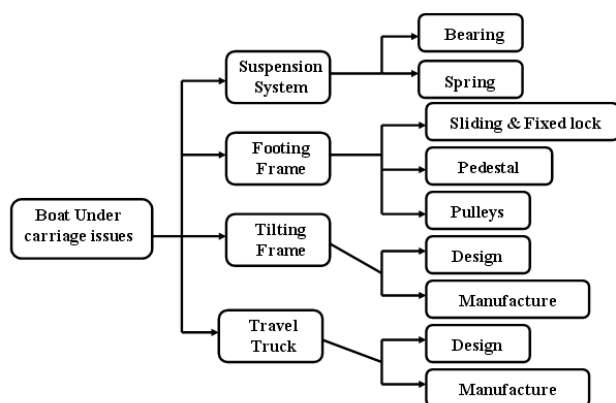


Chart -1: Boat under carriage sub-system issues

For the remaining sub-systems, i.e. the Tilting Frame and Travel Truck, further causative parameters were broadly classified as design related and manufacturing related.

As the indigenous Boat under carriage is based on a well-proven OE design, the consideration of design in the study was on the transfer of the original design intent into the indigenously manufactured Under Carriage.

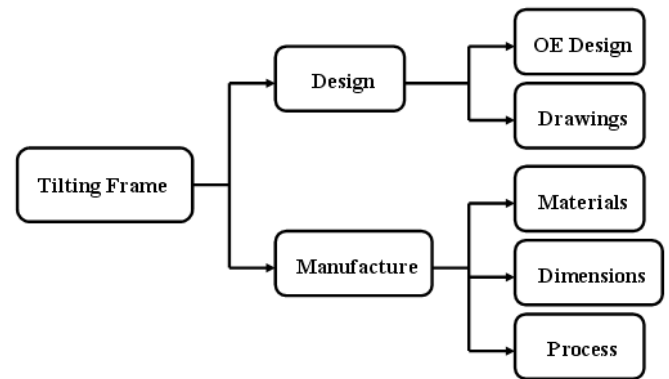


Chart -2: Tilting-frame design & manufacturing issues

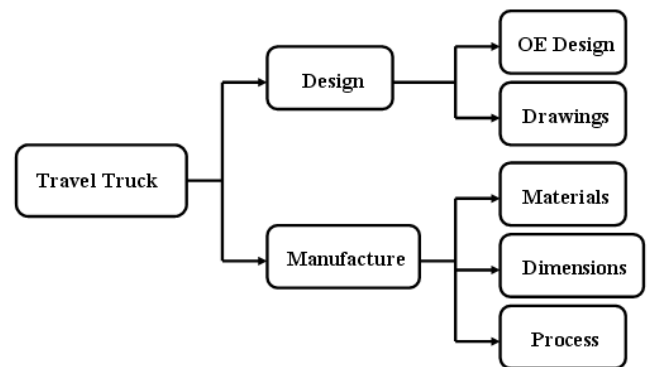


Chart -3: Travel Truck design & manufacturing issues

A broad comparison was made of the imported equipment and indigenous equipment, with attention focused on the two main assemblies viz tilting frame and travel truck. The following points were noticed:

1. The Tilting Frame sheets were 5mm thick in OE equipment but the indigenous frame and available OE drawings are with 4mm sheet
2. The gap between the travel truck rollers and the inside surface of the tilting frame is minimum, within 1.5mm, in the imported equipment; while in the indigenous equipment the gap varies up to 15mm
3. The spacing between the guide rails of the tilting frame in the case of imported equipment is  $2394 \pm 1\text{mm}$  whereas in the indigenous equipment there is variation of up to  $\pm 10\text{mm}$
4. Excessive play of rollers and guide wheels

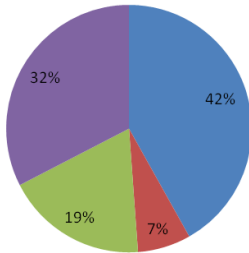
### 2.2. Field Report

For the present failure analysis, field report of Boat under carriage has been also considered. It is recorded that, majority of failures occurred during launching/retrieval of

boat in river due to Travel truck derailment from Tilting frame. See chart -4.

**Defects Reported**

- Derailing of Travel trucks
- Travel truck stopper broken
- Side Pulley Broken
- Purlin Lock Fouling with MTL Guide runner



**Chart -4:** Field report of Boat under carriage failure

From above Root cause analysis and field report, it is observed that Equipment failure is happening due to excess twist of Tilting frame under the river drag force. So, it is suggested to strengthen existing Tilting frame by FE analysis.

**2.3. Finite Element Analysis of Tilting Frame**

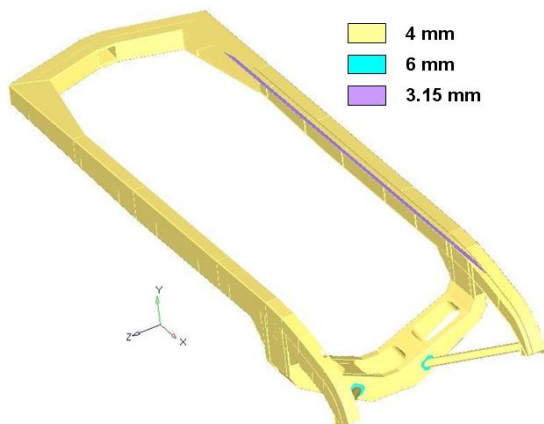
For FE analysis, geometry of Tilting-frame has been taken to find out twist of frame to determine failure.

**Table -1:** Materials of Tilting Frame

S. no	Component	Material (Std)	Yield stress
1	Structural frame- Plate construction	Fe510 - IS 5986	420 MPa
2	Tubing	DIN 2391	215 MPa

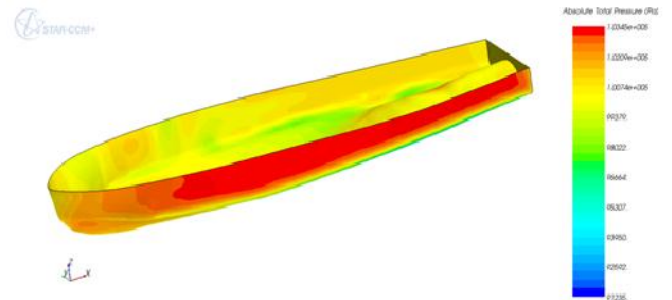
\*Std – Material standard

Tilting frame assembly comprises of Fe510 IS 5986 material plate construction and DIN 2391 tubing as shown in Fig - 2.



**Fig -2:** IGES Model of Tilting Frame

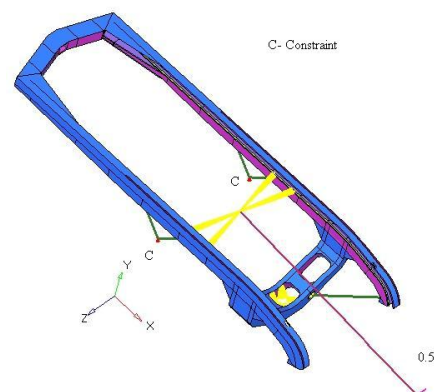
From the field report, derailment of Tilting frame recorded at river velocity which is above 1 knot (0.5 m/sec). For the present analysis, river velocity considered as 4 knots (2 m/sec). CFD analysis has been carried out to find out drag force on Boat.



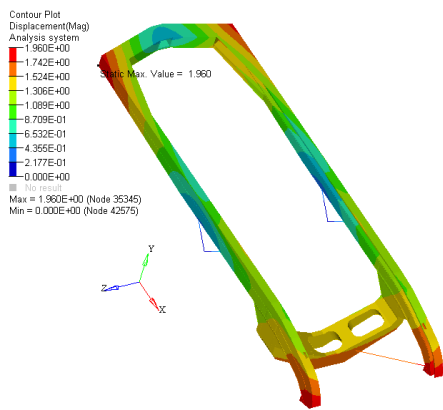
**Fig -3:** River current force on Boat (0.88t)

When Tilting-frame released to launch the Boat, it moves along with Travel truck on Roller support for smooth operation. Boat will be lifted up from Roller support when it goes around 60% in to waters (due to bouncy force). Now, boat will be having support only from Travel-truck. The river current force of 0.5 t (around 60% of 0.88 t) will be applied on supporting structure.

FE modeling (See Fig -4) and Solution of Tilting-frame structure carried out by Hypermesh and Nastran respectively under afore mention conditions.

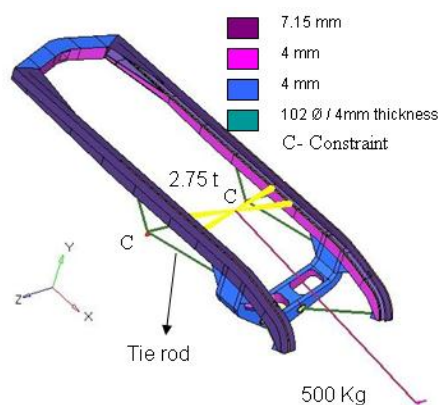


**Fig -4:** FE model of Boat under carriage Tilting Frame

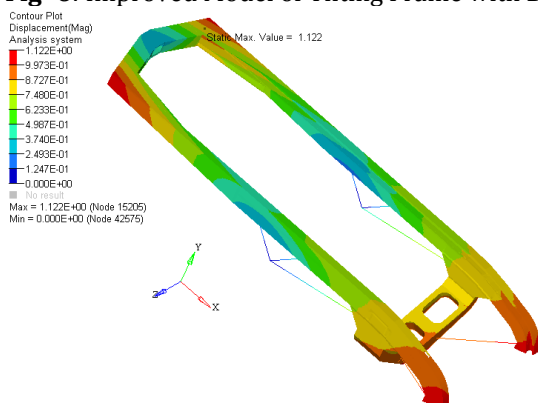


**Fig -5:** Displacement plot of Boat under carriage Frame

The max stress on Tilting frame is well within the limit of respective material. The twist reported under river current force is around 2 mm which is more enough to cause derailment of Travel truck from indigenized Boat under carriage (refer RCA). Based on FE analysis and Root cause analysis, Existing Tilting frame structure has modified as shown in Fig - 6.



**Fig -6:** Improved Model of Tilting Frame with BC



**Fig -7:** Displacement plot of modified Tilting Frame

Now, the maximum twist reported under river current force is around 1 mm which is self sufficient to operate Boat under carriage without failure (refer RCA).

### 3. CONCLUSION

From the detail study through Root Cause Analysis (RCA)/Failure Mode and Effects Analysis (FMEA) and field reports, it is learnt that the most of the failure are occurring due to River drag force (River current velocity above 1 knot). Also, it is reported that the indigenized Tilting frame of Boat under carriage has manufacturing and tolerance related issues.

CFD analysis has been carried to find out river drag force on existing Boat. FE analysis of the present Tilting frame of under carriage carried out to find actual twist due to river current force.

By FE analysis and inputs from RCA, Tilting frame has been modified to improve its structural integrity to make existing Boat Under carriage work without failure.

### REFERENCES

- [1] K. H. Bayer, "Engineering Design Handbook-Automotive series", AMCP 706-356.
- [2] Lingaiah, "Machine design Data book", The McGraw-Hill International, 2004
- [3] J E Shigley "Mechanical Engineering Design", 5<sup>th</sup> Edition, The McGraw-Hill international, 1986.