

# Automatic Welding Machine For Pipeline Using MIG Welding Process

Faiz F. Mustafa<sup>1</sup>, Mustafa I. Rao<sup>f 2</sup>

<sup>1</sup>Faiz F., Automated Manufacturing Engineering Department, Al-Khwarizmi College of Engineering, University Of Baghdad, Baghdad, Iraq

<sup>2</sup>Mustafa I., Automated Manufacturing Engineering Department, Al-Khwarizmi College of Engineering, University Of Baghdad, Baghdad, Iraq

\*\*\*

**Abstract** - Gas metal arc welding (GMAW) or as called metal inert gas (MIG) is used for welding pipeline, which is a semi-automatic arc welding process. Machine that hold and carry the welding gun of the MIG machine moving on a circular rail fixed near the pipe groove, can helpfully to improve the welding finish compared with the manual process by maintaining in parameters of welding such as keep the distance between the gun and the groove of weld joint, constant travel speed of the welding gun, also saving in time and funds. Many advantages such as maintain the health of workers, reduced in errors and troubles that occur during the welding process. The machine uses a three DC motors, one for moving around the pipe, the second used to control the gap, and the third for oscillating the welding gun. The process is automatically by welding a single V 75 degrees angle groove of pipe. Three forms of welding used to fill the groove between the two pipes, that forms are (1) line form, (2) zigzag (triangle) form, and (3) zigzag (square) form. A zigzag (triangle) form gives best and acceptable results when compared with the other two forms of welding.

**Key Words:** MIG welding, Automatic pipeline welding, Orbital pipeline welding, GMAW welding, Pipeline Welding Machine.

## 1.INTRODUCTION

Since the introduction of automatic orbital welding in pipeline application in 1961, significant improvements have been acquired, in orbital pipe welding systems. Requirement of more productive welding systems for pipeline application forces manufacturers to create new advanced systems and welding processes for the pipe welding method.

Kenji Kitano development of a totally automated both-side welding approach for pipeline creation changed into performed in term of mixing an inner clamp and welding device with an outside head welding device. A double-V butt joint become implemented with simultaneous three head operation (one inner and outside heads). Welding device "external head welding device" and "internal clamp and welding device" were evolved with a purpose to use a double -V- butt joint, outside heads, welding tool has advanced so that you can enhance the efficiency of operation improved range of welding torches ( from 1 to a

few torches), and decreased deposited location (single-V to double-V butt joint: about 50%) could lessen the welding time to approximately 20% of that required with the aid of the traditional computerized welding [1]. D. Yapp and S. A. Blackman develop Cranfield Automated Pipe welding System (CAPS), where tandem GMAW in a narrow groove has been applied to pipeline girth welding with two tandem torches in a single welding head The CAPS system offers welding productivity three to four times higher than that possible with the conventional single wire GMAW technique, while still producing a weld which is very similar to that generated by single wire welding which further reduces welding times, reduction in the number of welding stations required to achieve a given number of welds per day and this leads to major savings in labor and equipment costs. In comparing welding systems for a recent project estimate, CAPS resulted in a 25% saving in girth welding costs when compared with conventional mechanized GMAW systems [2]. Zeng Huilin, An automated welding gadget has been advanced by the way of use all-position self-shielded flux cored wire because of their blessings, system controls a welding carrier on a manual rail constant near the pipe joint to be welded and in addition to manipulate he welding speed, arc voltage, twine feeding pace, welding torch amplitude, frequency and exchange of other welding parameters. This gadget includes a welding provider, a manual rail, an vehicle-manage system, a welding supply, a wire feeder, and so on. it's been proved by using tests that computerized welding with the usage of self-shielded flux cored wire functions strong technique and sound formation of welded joints. Tensile energy, lateral bending performance, pressure, effect strength and different mechanical performance of welding joints [3]. Francois Nadeau and Jacques Blain, an "industrial" prototype was advanced. Its principal components are the welding head, comprising the arm and the help rolls, the positioner, that may pass on rails to deal with spools of diverse length, the welding energy supply with the two feeders, gas bottles and water cooling unit, and finally the controller. Two GMAW torches and a camera are mounted on the arm, which pivots away whilst the weld is finished to clear the workpiece for unloading. The straight torch is the only which operates at the side of the vision and prescient system and executes the root bypass. The switch mode is shrt-arc. The protective gas is 75% Ar., 25%CO<sub>2</sub>. The wire is 0.035" E70S-7.while the root

pass is completed, the second torch is mechanically activated then the weld is finished. The machine is at least four times as fast as manual, with excellent welding. The welds were radio-graphed, and mechanical tests have been achieved, which produces acceptable welds [4]. Satoshi Nakamura, advanced a brand new automatic narrow groove welding system mag for onshore gas pipelines. It has a through the arc sensor (arc sensor) and a imaginative and prescient based sensor. The imaginative and prescient-based sensor is used for controlling the traveling pace and the oscillation width for the root pass. The arc sensor is used for controlling the torch position and torch oscillation width for decent and filler passes. The gadget configuration and the specification consist of: (1) a welding head; (2) a controller; (three) pendant field; (4) guide rail; (5) an inner clamping gadget; (6) a electricity supply; and (7) defend gas. The use of an arc sensor and a vision-based totally sensor, examined the performance of the automatic manipulate era by way of girth-welding specimen metallic pipes in downhill welding sequences, nondestructive testing validated that the welded joints were lack of fusion, incomplete penetration and different flaw, produce great welded joints independent of the competencies of welders or welding operators [5].

**1.1 The Aims**

Due to the fact that standards are getting more stringent in pipeline welding, all joints are required to be uniform and it is difficult for the welder to comply with these requirements, and by growth of pipe welding applications. The need of automatic pipe welding machine that weld pipe in its location with higher productivity, greater weld quality, lower cost, and accuracy became one of the important requirements now.

- 1- Choose the best form for welding from three different forms in which the weld quality is high, and defect-free as possible.
- 2- Reduce the time required to complete the welding process with a reduction of workers, which increases productivity and profits.
- 3- Automatic welding process compared with manual welding and find differences between them.

**2. EXPERIMENTAL WORK**

The material of pipe that used was a low carbon steel that has the following mechanical and chemical properties as in table 1.

**Table -1:** Chemical and Mechanical properties.

<b>Chemical Properties</b>		
<b>Component</b>	<b>Standard</b>	<b>Tested</b>
C %	0.14	0.29
Mn %	≥ 0.6	0.576
P %	≤ 0.04	0.026
S %	≤ 0.05	0.002
Cr %	0.01	0.027
Mo %	0.001	0.001
Ni %	0.016	0.014
Cu %	0.003	0.007
V %	0.001	0.003
Fe %	≥ 98.81	99.054
<b>Mechanical properties</b>		
<b>Test</b>	<b>Standard</b>	<b>Tested</b>
UTS (MPa)	480	475
UBF (KN)	23.51	21.26
Hardness	173.6	171.81

**2.1 MIG Welding Process**

Gas metal arc welding (GMAW), once in a while mentioned by its sub-types metallic inert gas (MIG) welding, is a semi-automatic or automatic arc welding system in which a non-stop and consumable cord electrode and a protecting gasoline are fed via a welding gun. A regular

voltage, direct current power source is most typically used with GMAW. GMAW is the maximum not unusual business welding manner, preferred for its versatility, velocity and the relative ease of adapting the system of automation robot. The different equipment parts of MIG welding will be explained. The equipment consists of (1) power source, (2) welding gun, (3) electrode bobbin, (4) rod feeder, (5) controller, (6) water supply, (7) a shielding gas supply, and (8) work piece, see Figure 1 for an overview of the welding equipment's [6]. The motive of the twine feeder is to supply the welding gun with the electrode cord which depending in which the rod feeder positioned, the wire is either pulled or pushed. protecting gases are vital for gas metallic arc welding to defend the welding area from atmospheric gases which include nitrogen and oxygen, that may purpose fusion defects, insufficient weld penetration (argon) or cause an erratic arc and encourage spatter (with helium). Argon is also commonly blended with other gases, such as oxygen, helium, hydrogen and nitrogen [7].

gases which include nitrogen and oxygen, that may purpose fusion defects, insufficient weld penetration (argon) or cause an erratic arc and encourage spatter (with helium). Argon is also commonly blended with other gases, such as oxygen, helium, hydrogen and nitrogen [7].

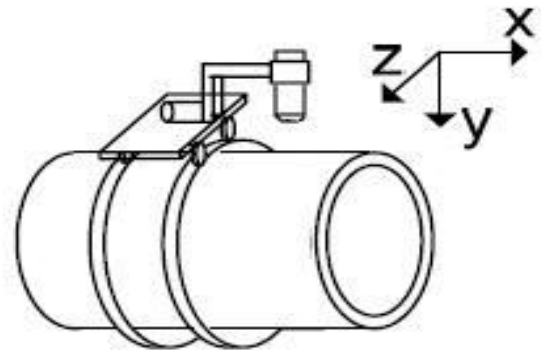

Fig-2: Coordination of traveler system of the machine.

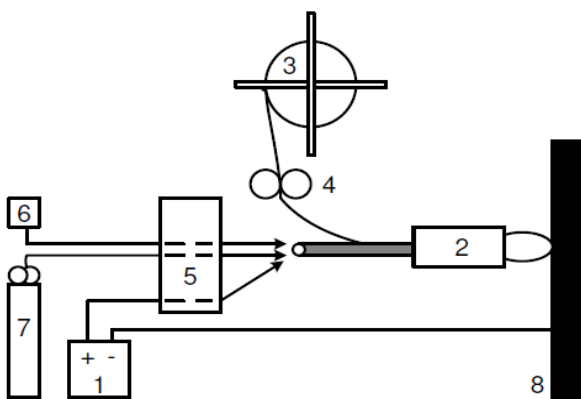

Fig-1: Overview of MIG welding equipment's.

2.1 MIG Welding Process

Gas metal arc welding (GMAW), once in a while mentioned by its sub-types metallic inert gas (MIG) welding, is a semi-automatic or automatic arc welding system in which a non-stop and consumable cord electrode and a protecting gasoline are fed via a welding gun. A regular voltage, direct current power source is most typically used with GMAW. GMAW is the maximum not unusual business welding manner, preferred for its versatility, velocity and the relative ease of adapting the system of automation robot. The different equipment parts of MIG welding will be explained. The equipment consists of (1) power source, (2) welding gun, (3) electrode bobbin, (4) rod feeder, (5) controller, (6) water supply, (7) a shielding gas supply, and (8) work piece, see Figure 1 for an overview of the welding equipment's [6]. The motive of the twine feeder is to supply the welding gun with the electrode cord which depending in which the rod feeder positioned, the wire is either pulled or pushed. protecting gases are vital for gas metallic arc welding to defend the welding area from atmospheric

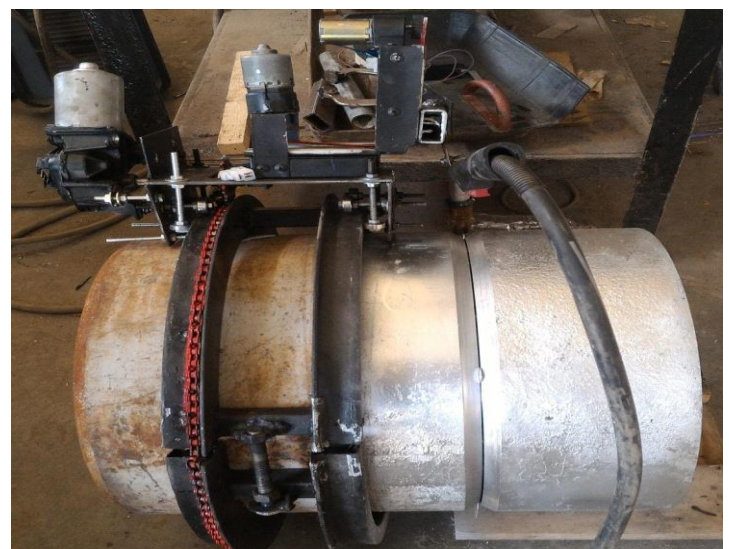

Fig-3: Automatic pipeline welding machine.

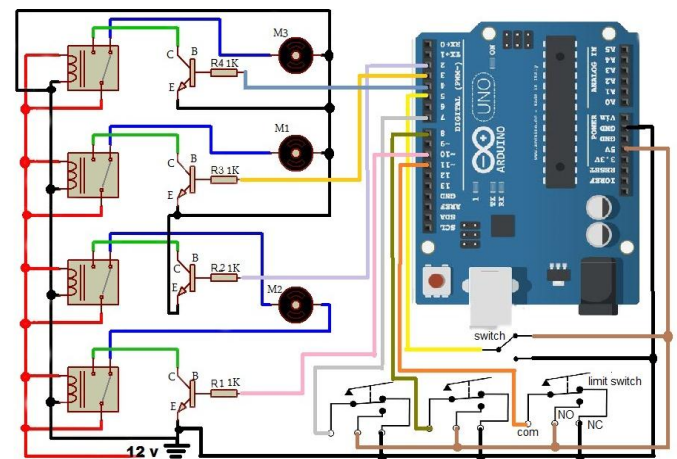

Fig-4: Electrical circuit with Arduino to control the machine.

### 2.3 Welding Process Using Automatic Machine

In the beginning, the groove of pipe that wants to join is different such as U and V groove which depending on the thickness of the base metal. The included angle of the pipe is 75 degrees. In order to obtain this angle when the pipes are brought together for welding, the bevel angle at the end of each pipe should be equal to one-half of the included angle or 37 ½ degrees, as shown in Figure 5. Root pass welding was done before the fill pass, fill pass takes most part of welding time and usually consisting of numbers of layers, and each layer consisted of several passes [8][9].

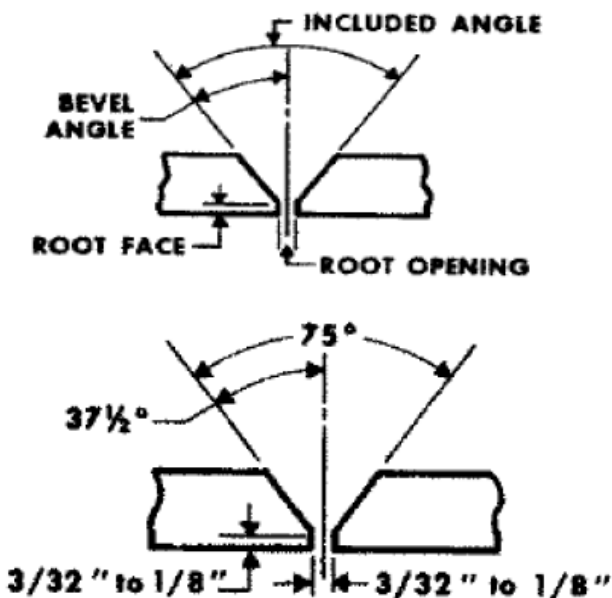

Fig-5: Standard joint specifications for thick-well pipe.

MIG welding parameters set, the selection of wire depends on the type of base metal to be welded. The most common type of MIG wire for welding mild steel is ER70s-6. The wire diameter used in the welding was about (0.9mm) and its type was ER70s-6. The primary purpose of shielding gas is to prevent exposure of the molten weld pool to surrounding. The reason of choosing Argon as a shielding gas was that it is heavier than air and typically need lower flow rates than mixtures. The flow rate of gas depending on the thickness of the material, thinner materials of 1-3 mm thick need 8-12 liters per minute, for thicker materials the flow rate around 15-20 liters per minute. The voltage setting varies depending on (1) size of the electrode used, (2) how thick the metal is, (3) and what type of gas is used, for calculating the current, 1 Ampere need for every 0.001 inches (0.0254mm) thickness, so for pipe with thickness 0.472 inch (12mm) we need about 472 amperes. Typically, welding of pipe with wall thickness up to nearly 3mm can be done in a single pass while for thicker pipe wall, a multi-pass is required. In general, the multi-pass process is divided into a series of phases: root

pass, fill pass, and cap pass. The first stage of welding pipe was the root pass, which fill the gap (root opening) between the two pipes [10][11].

Fill passes welding stage different from root pass, as the root weld done in one stage while fill pass need multi or more stages to complete the whole stage. Different types of welding shape can include in that stage to fill the welding area (a) line welding, (b) zigzag (triangle), and (c) zigzag (square), as shown in Figure 6.

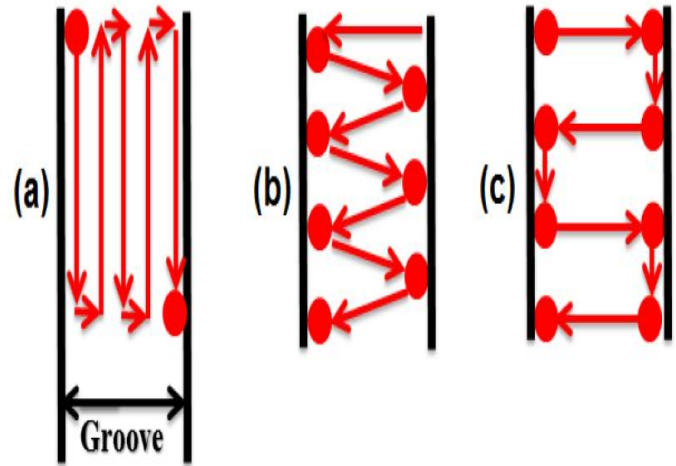

Fig-6: The three forms of welding that use to weld the pipe.

### 3. RESULTS AND DISCUSSION

Tests such as tensile strength, and bending tests were applied on samples taken from the pipe after welding. The purpose of these tests was to find out which type of welding was the best welded quality according to the results of these tests.

#### 3.1 Ultimate Tensile Strength Test (UTS)

To find out the best form of welding of the three forms that mentioned earlier, and conduct the necessary tests to determine the extent of its success. The first form has welding was line welding form. Figure 7, explain the UTS curve for three samples welded with that form. By setting the correct parameters for this form of welding, after welding is completed, cutting tensile samples examined. Experiments (1,2, and 3) samples welded gives UTS of 165, 170, and 138 MPa respectively with average 157.6 MPa., with maximum load of 55.142, 57.186, and 52.84 KN respectively, the average is 55.056 KN.

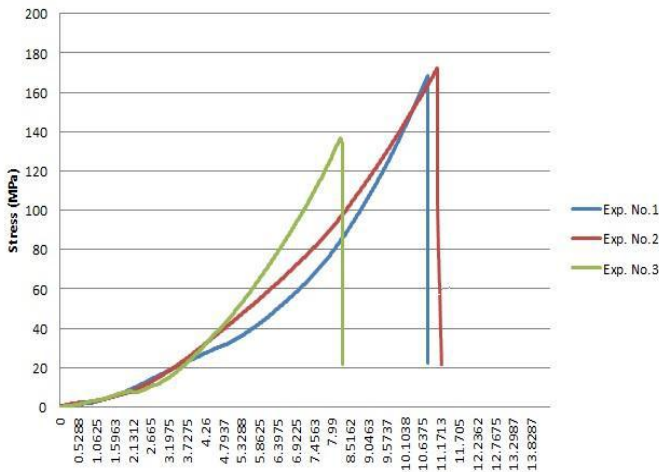

**Fig-7:** UTS for three samples welded with a line form.

Experiments (7,8, and 9) that welded with a zigzag (square) form, and the stress-strain curve for these samples shown in Figure 9. The UTS for these samples are 445, 465, and 460 MPa. respectively where the average is 456.6 MPa., and the maximum load are 67.817, 69.37, and 68.36 KN respectively where the average is 68.515 KN. When compared the welded samples we get 96.12% of UTS of the base metal, and 94.33% of maximum load. Also high deformation occurs on the samples before its failure, where the failure was near the area of the welding zone, which gives a positive result for the welded area. When comparison between this form and the line form, this form is definitely better by the results we have obtained, and when the comparison with the zigzag (triangle) form, the zigzag (triangle) comes in the first place, followed by zigzag (square) form.

The average UTS of welded metal is 157.6 MPa, if this result was compared with the original metal before welding process, we find that the percentage difference between the average of the UTS of the base metal 475 MPa and average of the welded samples 157.6 MPa was about 33%, and percentage between the average maximum load of base metal 72.63 KN and average of welded samples 55.056 KN was 75.8%. Curve in Figure 10. reached the stage of failure quickly and the yield point almost non-existent, with small deformation where the failure occurred in the welded area that gives a weak welded area.

Experiments (4,5, and 6) that welded with a zigzag (triangle) form. The UTS shown in Figure 8 which show the stress-strain curve for samples welded with that form tested. The UTS values of these samples are 475, 470, and 470 MPa. Respectively, where an average of UTS of these samples is 471.66 MPa., and the maximum load can afford was 71.19, 70.77, 77 and 71.93 KN. respectively with average 71.29 KN. When comparing the results of samples after welding with the base metal, we found that the percentage was 99.29% of the original metal before welding in term of UTS, and 98.15% in term of load. High deformation occurs on the samples before its failure, where that failure was near the

area of the welding zone. Since the welding area endured high load before they reach the stage of failure. When comparing this form of welding with the previous form, and through the results we have obtained note that welding with this form is better than the previous.

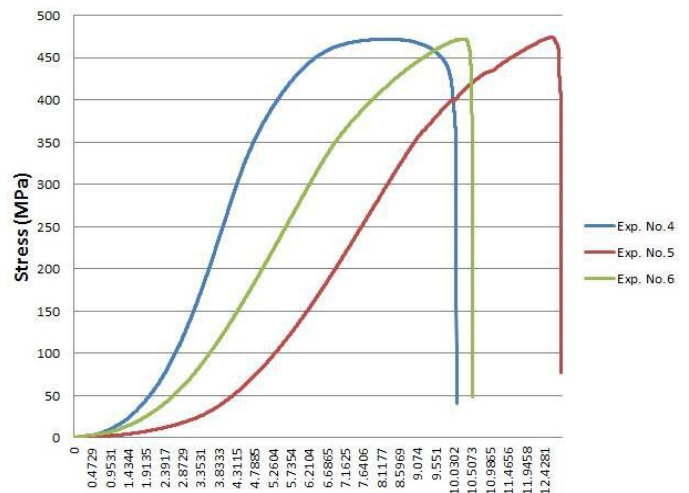

**Fig-8:** UTS for three samples welded with a zigzag (triangle) form.

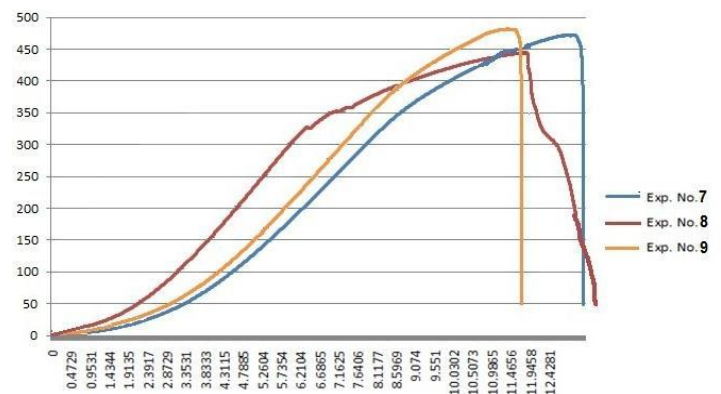

**Fig-9:** UTS for three samples welded with a zigzag (triangle) form.

### 3.2 Ultimate Bending Force (UBF)

. Line welding form was done, and samples were taken for the purpose of bending tests, Figure 10 shown the UBF for two samples welded with this form. The maximum load can afford for samples welded with line form is 11.83, and 11.65 KN respectively, where the average is 11.74 KN. When compared that result with the average base metal before welding 21.267 KN and the average of welded parts we get 55.2% of the maximum load of the base metal can the welded part afford. From the curve, the samples reach the failure region quickly with very small deflection occurred in the tested sample with that load. The force rapidly diminishing that indicates the welding area failed because it cannot afford these large loads.

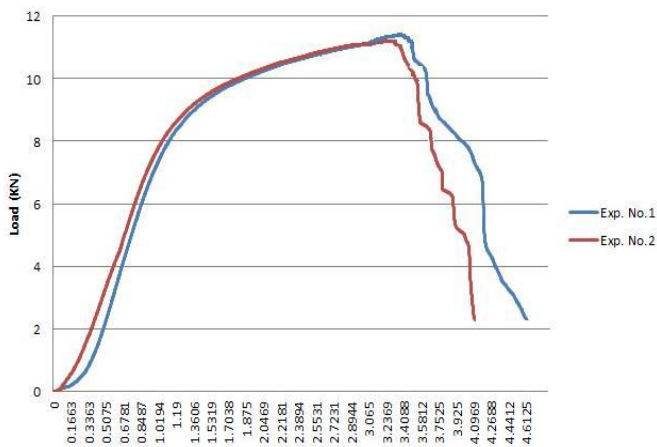

Fig-10: UBF for two samples welded with a line form.

In Figure 11, the UBF curve of two samples welded with a zigzag (triangle) form. From curve, we see that the samples can afford a maximum load was 19.42 KN for the first sample, and 19.83 KN for the second sample, the average is 19.625 KN. The deflection was 10.63mm, and 10.96 mm respectively. When compared these results with the results of the base metal, we find out that the sample that welded with this form has 92.27% of the maximum load afforded. While the failure on these samples occur in the welded zone, but we can see that the joint bear that load for a period before it reach the failure stage.

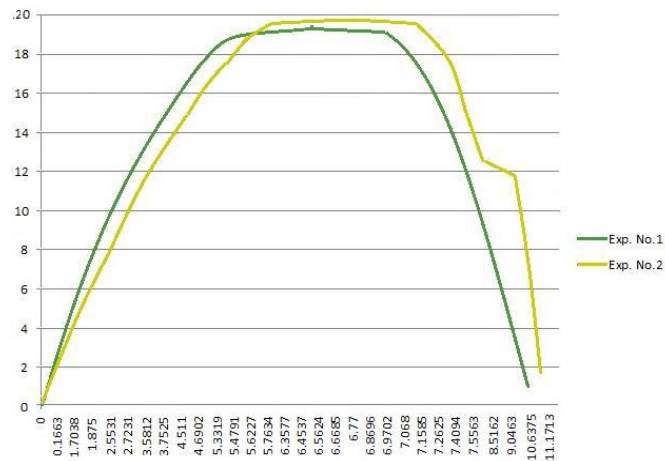

Fig-11: UBF for two samples welded with a zigzag (triangle) form.

Zigzag (square) form was the final form weld; the figure 12 shows the curve of UBF for two samples. From the curve, the maximum load that the samples afforded was 17.91 KN for the first sample, and 17.59 KN of the second sample, the average is 17.75 KN, by comparing the results with the base

metal result we find that 83.46% can the welded sample load afford. For that results, the welding with a zigzag (triangle) form which give the best results that approach the

base metal with high rate, making it come the first place followed by a zigzag (square) form.

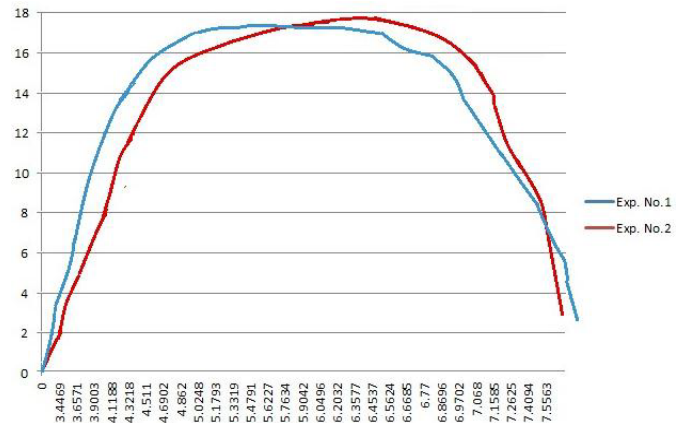

Fig-12: UBF for two samples welded with a zigzag (square) form.

#### 4. CONCLUSIONS

The thesis was on the automatic pipe welding machine, and chooses the best form of welding between the three forms that mentioned earlier. Reduce the costs that can be obtained by reducing the number of workers, in addition to reducing the damage in the material where there is no change in the welding from start to finish as the gap remains constant, and constant speed of movement of the welding gun, all this in addition to time need to finish the process reduce costs offset by an increase in profits. The results of tensile, and bending plays a big role in the outcome of the tests that interference as the main reason for the failure or success of the welding area. Note that welding with a zigzag (triangle) form was the best way to weld in compared with the two other forms. From the results of tests with comparison with the original metal in the tensile, and bending note that welding with a zigzag (triangle) form gives 99.29% of the original metal before welding in term of UTS, and 98.15% in term of load for tensile test, and 92.27% of the maximum load afforded for UBF. These results, which are made the welding in a zigzag (triangle) form is one of the best forms of welding. The whole process is healthy to the worker as they don't interfere directly, since the effect of the smoke and gases that produced by the process does not have a direct impact and its impact on workers less compared with the manual process.

#### ACKNOWLEDGEMENT

I like to extend my thanks and appreciation to my supervisor **Asst. Prof. Dr. Faiz F. Mustafa** for his scientific guidance, valuable advice, continuous follow up throughout the research and writing of this thesis. Also thanks and gratitude to my family, who supported their confidence in me that drove me to this stage.

## REFERENCES

- [1] Kenji Kitano, Masahito Ikebe, Hiromi Shiraishi, and Tatsuya Kasatani, "Development of Fully Automatic Both - Side Welding (GMAW) for Pipeline", 13th International Symposium on Automation and Robotics in Construction, Tokyo- Japan, June 11-13, 1996, pp.239-246.
- [2] D. Yapp, and S. A. Blackman, "Recent Developments in High Productivity Pipeline Welding", Journal of the Brazilian Society of Mechanical Sciences and Engineering, Vol. XXVI, No. 1, 2004, pp. 89-97.
- [3] Zeng Huilin, Wang Changjiang, Yang Xuemei, Wang Xinsheng, and Liu Ran, "Automatic welding technologies for long-distance pipelines by use of all position self-shielded flux cored wires", Natural Gas Industry B1, 2014, pp. 113-118.
- [4] Francois Nadeau, Jacques Blain, "AUTOMATION OF PIPE WELDING USING MACHINE VISION AND ADAPTIVE CONTROL", Review of Progress in Quantitative Nondestructive Evaluation, Plenum Press, New York, Vol. 9, 1990, pp. 1957-1964.
- [5] Satoshi Nakamura, Yuichi Furikawa, Yasuyuki Ikuno, Shinji Kodama, Tsuyoshi Maeda, "Automatic Control Technology of Welding Machine MAG-II for Onshore Pipelines", NIPPON STEEL TECHNICAL REPORT, No. 92, July 2005, 51-55.
- [6] Irina Gertsovich, and Niklas Svanberg, "Analysis of MIG Welding with Aim on Quality", School of Engineering at Blekinge Institute of Technology, M.Sci of Electrical Eng., Sweden, 2008.
- [7] Hamidreza Latifi, "Advanced orbital pipe welding", Lappeenranta, Finland, 2012.
- [8] B. Mannion, "The fundamentals of orbital welding" Gases & Welding Distributor, Vol. 44, No. 1, 2000.
- [9] H. S. Moon, Y. B. Kim, and R. J. Beattie, " Multi Sensor Data Fusion for Improving Performance and Reliability of Fully Automatic Welding System", International Journal of Advanced Manufacturing Technology, Vol.28, 2006, pp. 286-293.
- [10] Klas Weman, Gunnar Linden, "MIG Welding Guide", Woodhead Publishing, 2006.
- [11] Hoobasar Rampaul. Pipe Welding Procedures 2nd ed. New York: 2003.