

Advance Wind Mill

Ashwin.V.Chandrashekhar¹, Akash.N.Deshmukh², Kasturi.A.Thorat³, Prajwal.A.Mahajan⁴,
Shubham.S.Barhate⁵, Sudhanva.W. Khedkar⁶

¹Student, Dept. Of Mechanical Engineering, SIEM college, Maharashtra, India

²Student, Dept. of Electrical Engineering, SIEM college, Maharashtra, India

³Student, Dept. of Civil Engineering, SIEM college, Maharashtra, India

⁴Student, Dept. of Mechanical Engineering, SIEM college, Maharashtra, India

⁵Student, Dept. of Civil Engineering, SIEM College, Maharashtra, India

⁶Student, Dept. of Civil Engineering, SIEM college, Maharashtra, India

Abstract - The function of windmill is to produce electricity with air as in input and flywheel and generator as working elements. But there are some restriction in this technique, the production of the electricity completely depends upon the presence and the velocity of the wind. Hence electricity can only be produced in presence of sufficient amount of wind flow. To overcome these restrictions, we have introduced an **Advanced Windmill Technique**. In this technique electricity can be produced all irrespective of flow of wind and the time of day i.e. 24×7. In this technique, hollow pipe is used in which vacuum is created by exhaust fan and flywheel is placed in this hollow pipe. Exhaust is placed at the end of tube with it's own electricity generation assembly. This method can give us more efficiency than the existing ones.

Key Words: Vacuum tube, Flywheel arrangement, Exhaust, Power generation from exhaust, faraday's electromagnetic principle

1.INTRODUCTION

For the development of our country the availability of energy in vast range is very important. Energy is present in many forms like heat, wind & so on. The most important form of energy is electrical energy because our modern society is so much dependent upon the use of electrical energy. Due to this production of electricity in large scale is essential. For the large production of electricity, we need to develop new techniques by which electricity can be produced efficiently and economically. This paper introduces a new technique of production of electricity by Advance Wind mill.

There are several methods of generation of electricity like thermal, nuclear, solar, hydro, wind mills etc. All of this we can only produce electricity efficiently by solar and

windmills only. But there is restriction in this method. In the solar we unable to produce energy during the night time and in the wind mill the generation of electricity is totally dependent on the speed of the air. In this paper we have introduced a new technique which is the **advancement of the wind mill technique**.

By this technique we can produce electricity constantly, which is more than the wind mill. In this technique we use air tube, flywheel, exhaust fan for electricity generation. The efficiency of this plant is greater than wind mill because in this technique we produce electricity in 3 ways i.e. by **flywheel, exhaust fan and solar plates**.

2. OBJECT

The main advantage of this technique is we can produce electricity more efficiently than wind mill. In practical the cost of manufacturing of the wind mill is more. So in case if the windmill doesn't provide us with sufficient amount of energy then it becomes a less efficient program. This newly introduced technique i.e. **Advance Wind mill** provides us with much more efficient program. Here, electricity can be produced by **flywheel, exhaust fan and solar plates** and electricity should be provided to the **exhaust fan** only. The electricity is produced by flywheel in the traditional way like that of wind mill. The Exhaust fan has 2 functions, the primary function of the exhaust fan is to create vacuum in the air tube and secondary function of the Exhaust fan is to produce electricity, it's based on the Faraday's Electromagnetic induction. Here, permanent magnets play an important role. For making this technique more efficient we use solar plates. The produced energy is used for working of the exhaust fan. Due to this, Advance Wind mill works more effectively than the other electricity generation techniques.

3. CONSTRUCTION

- Air tube construction
- Flywheel & Dynamo construction
- Power Generative Exhaust construction
- Air tube construction: -

1. Air tube is like a hollow pipe, with front & back opening.
2. Flywheel is placed on the front side & the back opening consists of power generative exhaust fan.
3. Multiple tubes can be used here. The number of air tubes depends on the requirement of the power generation or the location at which plant is set up and amount/velocity of air.
4. These all tubes are placed above the ground at a definite distance with the help of rods or stands which are fixed to the ground.

- Flywheel & dynamo construction: -

1. Flywheel is placed in front side of tube, in the vertical manner inside the air tube as shown in the figure.
2. The dynamo is connected to the flywheel with the help of shaft & gears.
3. Gears are provided for speed controlling.
4. Dynamo is placed outside of the tube and connected to the grid system.
5. Flywheel is placed on the side of the air tube, from where the air enters inside the tube.

- Power Generative Exhaust Fan Assembly Construction: -

1. The Exhaust fan is placed on back opening of the tube.
2. A circular ring, which is mounted by copper winding is placed in the air tube around the exhaust fan blade.
3. For the working of the exhaust fan electrical supply is provided externally.
3. Another circular ring whose diameter is smaller than 1st circular ring is fitted on the blade of the exhaust fan.
4. On the outside of the 2nd circular disc, the permanent magnets are fitted with the help of nut & bolts. Exhaust assembly is used for electrical power generation.

5. The EMF induced in the exhaust assembly is then stored in the battery.

4. DIAGRAMS: -

- Air tube
- Flywheel
- Dynamo
- Principle of generation of electricity in dynamo
- Exhaust Fan

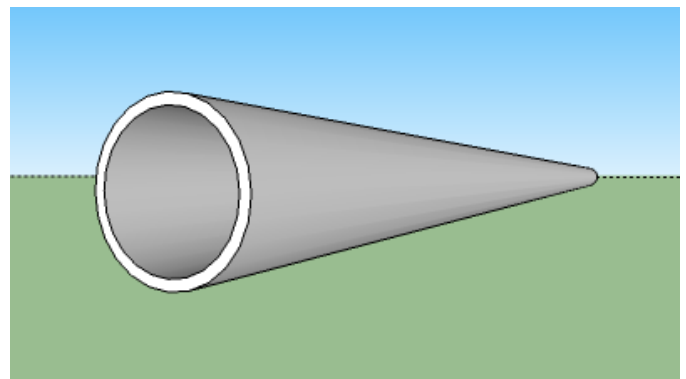

Fig. a) Air Tube

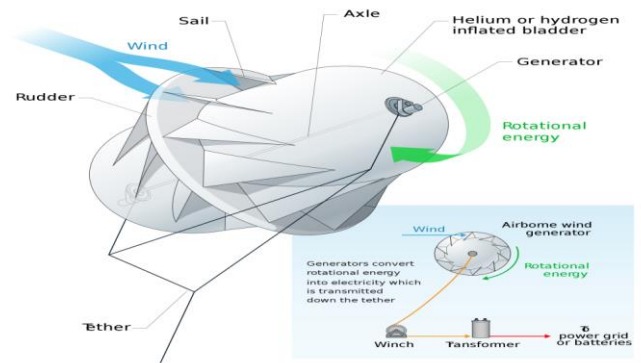

Fig. b) Flywheel

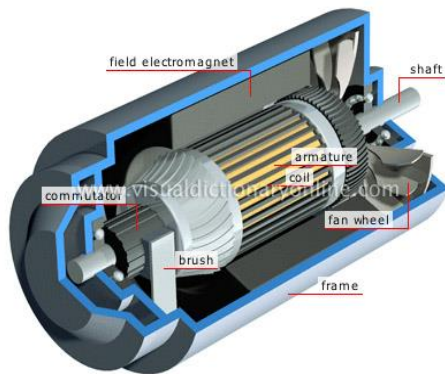

Fig. c) Dynamo

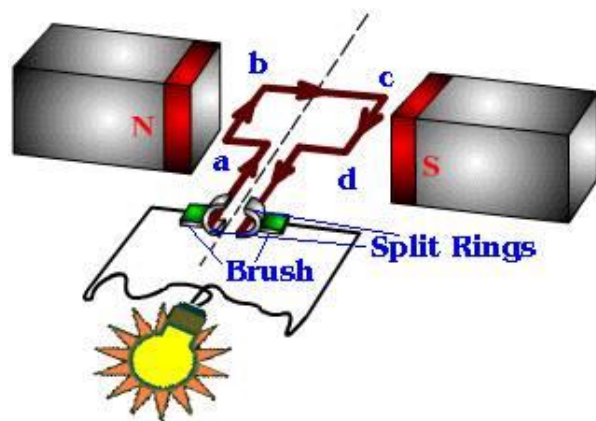

Fig. d) Principle of generation of electricity in dynamo & exhaust fan assembly

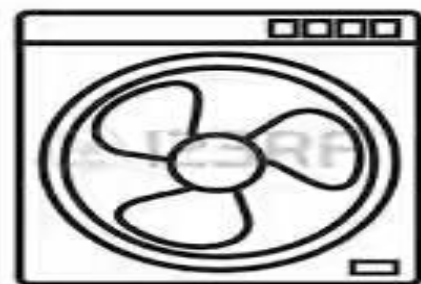

Fig. e) Exhaust Fan With power generative assembly

5. WORKING

In the **Advance Wind Mill technique** power in the form of electrical energy is generated by 3 ways:-

- By flywheel.
- By Exhaust fan
- By Solar Plates.
- By Flywheel: -

Flywheel is placed at the front side of the tube. The principle of generation of electrical energy of the flywheel is same as that of wind mill. The principle is like that, "we use kinetic energy of wind as the input, this kinetic energy is converted into mechanical energy by the flywheel and this mechanical energy is converted into the electrical energy with the help of dynamo."

The wind entering inside the air tube strikes the blades of the flywheel. As soon as the wind strikes blades the flywheel start rotating. The dynamo is connected to the output of the flywheel with the help of a shaft. As the flywheel rotates, generation of electrical energy takes place.

The generation of electrical energy depends on the following factors: -

1. Velocity of the wind.
2. Number of the rotations in rpm of the flywheel.

The electrical energy is generated by flywheel which is controlled by gears that are mounted on the shaft. (Shaft which connects the flywheel and dynamo).

- By exhaust fan: -

Main function of Exhaust fan: -

The function of exhaust fan is to push the in air outside. Here we have placed the exhaust fan at the end of the air tube, i.e. at the back side of the flywheel. Exhaust fan is connected to the external electrical supply for it's working. When the exhaust fan starts it pulls the inside air in the air tube to outside or another air tube. Due to this process more air comes inside the tube, this results in generation of more energy by flywheel. According to the requirement we use exhaust fan, by the use the of flywheel we can produce energy at constant quantity at the low velocity of the air.

- Electrical energy produced by the exhaust fan: -

Principle

“The Exhaust Fan works on the principle of generator. It works on the Faraday’s law of electromagnetic induction. The law states that, when electrical conductor placed in the strong magnetic field and when the magnetic lines of force cuts the conductor then EMF is induced on the surface of the conductor”.

On the blade on the flywheel we have placed a ring as shown in fig. The outside of the ring permanent magnets is placed with the help of nut & bolts. Another circular ring is used which has larger diameter than the 1st ring. This ring is made by copper and the copper winding is placed on this ring. This copper winding ring is placed exactly around the 1st ring. The gap between both the rings is of few mm. As the exhaust fan starts, the blades of exhaust fan rotates due to this the ring which is placed on the blades which also rotates and the rotating magnetic field (RMF) is produced in the gap between the rings. This RMF cuts the copper winding and the EMF is induced in the copper winding due to magnetic induction. This produced EMF is stored in the batteries.

The reduction in the speed of the wheel is negligible. Because if you have a strong enough magnetic field all ferromagnetic materials become magnetic in nature. But copper is so weakly magnetic that we can't observe it without very, very large magnetic fields. So the short answer is "No, copper isn't magnetic." This can quickly be tested by trying to pick up a penny with a magnet.

The production of electricity in the exhaust is depends on:-

1. Number of poles
2. Flux produced by each pole
3. Number of turns of the copper winding
4. Rotation of blades

Controlling of the generation is not possible during the working of exhaust. Generation can only be stopped by switching off the fan. But if use electromagnets instead of permanent magnets, we can easily control the generation of electricity at the fans working period.

The EMF induced in the copper winding is measured by total production of flux divided by number of rotation.

Total EMF produce = Total Flux ÷ Number of rotation

Total Production of flux = Number of poles × flux generated by each pole

Number of rotation = 60 ÷ Speed

- Solar Plates: -

To make this project more efficient we use solar energy for electrical production. This produced electricity is generally used for exhaust fan.

We assemble solar plates on the upper surface of the tube. The produced energy is stored and used for other applications.

ADVANTAGES: -

- By this technique electricity can be produced 24×7.
- The amount of generation of electricity is more than ordinary wind mills (because of use of exhaust fan).
- The electricity is generated by 3 ways in a single plant. So the amount of electricity generation is greater.
- The cost of production is cheap.
- This technique is not harmful to nature, i.e. ecofriendly.
- Simple in construction.

DISADVANTAGES: -

- Initial cost is high.
- Requires periodic maintenance.

CONCLUSION: -

The conclusion of this paper is that we have introduced a new technique of electricity generation. This technique is efficient than existing ones. Different techniques can be used for power generation in a single plant itself. Advance Wind Mill technique carry away the restriction of the traditional wind mill technique.

REFERENCES

- [1] *Faraday, Michael (1822). "On Some New Electro-Magnetical Motion, and on the Theory of Magnetism". Quarterly Journal of Science, Literature and the Arts (Royal Institution of Great Britain) XII: 74–96 (SIX). Retrieved 12 February 2013.*
- [2] *"The Development of the Electric Motor.", Early Electric Motors. SparkMuseum. Retrieved 12 February 2013.*
- [3] *Pansini, Anthony J. (1989). Basic of Electric Motors. Pennwell Publishing Company. p. 45. ISBN 0-13-060070-9.*