

## Contactless Speed Monitoring And Displaying

Soumya Das<sup>1</sup>, Pratyusha Biswas Deb<sup>2</sup>, Sreeja Chakraborty<sup>3</sup>, Nilkantha Nag<sup>4</sup>, Molay Laha<sup>5</sup>, P.S.Majumdar<sup>6</sup>

<sup>1,3,4,5</sup> Student , Dept Of Electrical Engineering, Narula Institute of Technology, West Bengal, India

<sup>2</sup>Associate Professor, Dept of Electrical Engineering, Narula Institute of Technology, West Bengal, India

<sup>6</sup>Associate Professor, Dept Of Physics, A.P.C College New Barrackpore, West Bengal, India

\*\*\*

**Abstract** –This paper presents a new approach for contactless speed motoring and displaying. In the proposed study, we have shown the process of carrying out speed monitoring and displaying without any contact with the rotating device by using microcontroller & diodes.

**Key Words:** IR Diode, Photo diode, Microcontroller, keil compiler.

### 1. INTRODUCTION

Speed monitoring of a motor is one of the important factors to be considered while dealing with D.C motor so as to obtain the desired output. In this age of digitized technology, measurement of physical variables especially speed in digital form becomes a matter of considerable interest. In industries where control system is an important factor, the accurate measurement of angular speed in digital form is required in the most of its instrumentation and control application.

Previously two types of technologies are employed, contact type and non-contact type. With the development of technologies successful attempts have been made to measure the angular speed in digital form using Optical transducer [1-3] and capacitive transducer [4]. But both of them have some drawbacks. Optical transducers either require high degree of vibration, less eccentricity-free motion and special environment conditions. Along with that it not cost effective. On the other hand capacitive transducer suffers from high output impedance and frequent occurrence of noise. So, to avoid all the above problems a new technology has been introduced with Infrared and Photo diode for accurate angular speed measurement. With the introduction of microcontroller it is made cheaper

and access able and the output has been fed from the microcontroller to a LCD display.

### 2. COMPONENTS REQUIRED

The specifications of the component required are:

- 1) Resistor:  
330  $\Omega$  , 100  $\Omega$  , 1k  $\Omega$  , 10 k  $\Omega$  .
- 2) Capacitor:  
470uF/63V, 33pF Ceramic.
- 3) Integrated Circuit:  
IC 7805 is used.
- 4) Microcontroller:  
IC 89S52 is used as a microcontroller. It has been feed with C program compiled in keil compiler [5].
- 5) Diode:  
Diode 1N4007 is been used.
- 6) Transistor:  
Transistor BC547 has been used.
- 7) Crystal oscillator:  
11.0592 MHz CRYSTAL oscillator has been used.
- 8) IR- Diode:  
An infrared emitter, or IR emitter, is a source of light energy in the infrared spectrum. It is a LED that is used in order to transmit infrared signals from a remote control. A remote with strong emitters can often be used without directly pointing at the desired device. Infrared emitters are also partly responsible for limits on the range of frequencies that can be controlled. An IR emitter generates infrared light that transmits information and commands from one device to another. Typically one device receives the

signal that passes the infrared (IR) signal through the emitter to another device.

9) Photo diode:

A photodiode is a semiconductor device that converts light to current. The current is generated when photons are absorbed in the photodiode. A small amount of current known as dark current is produced when no light is present. Photodiodes may contain optical filters, built-in lenses, and may have large or small surface areas. Photodiodes usually have a slower response time as their surface area increase.

10) 12 V D.C. FAN:

Brushless DC electric motor (BLDC motors, BL motors) also known as electronically commutated motors (ECMs, EC motors) are synchronous motors that are powered by a DC electric source via an integrated inverter/switching power supply.

11)LCD16X2: LCD (Liquid Crystal Display) screen is an electronic display module and find a wide range of applications. A 16x2 LCD display is very basic module and is very commonly used in various devices and circuits. These modules are preferred over seven segments and other multi segment LEDs.

12) Power chord: Power chord is used to connect the transformer to the main supply.

13)Transformer:A transformer is an electrical device that transfers energy between two or more circuits through electromagnetic induction. Commonly, transformers are used to increase or decrease the voltages of alternating current in electric power applications. A varying current in the transformer's primary winding creates a varying magnetic flux in the transformer core and a varying magnetic field impinging on the transformer's secondary winding. This varying magnetic field at the secondary winding induces a varying electromotive force (EMF) or voltage in the secondary winding.

3.METHODOLOGY

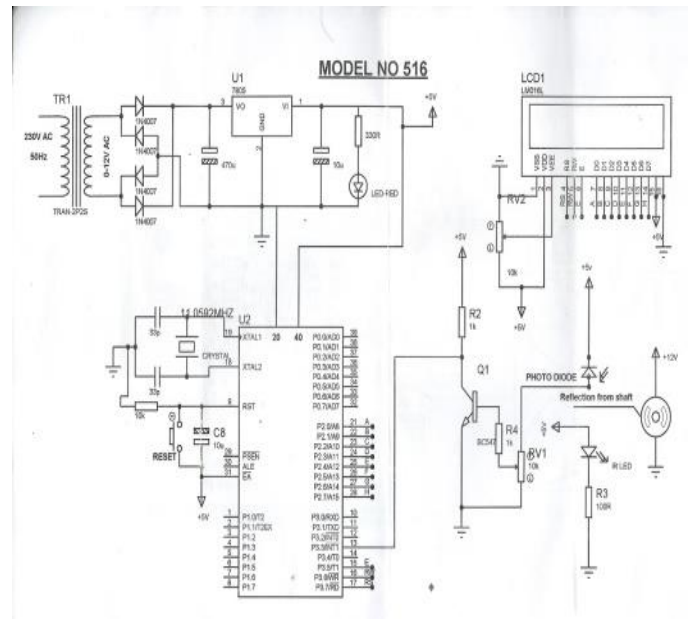

Fig -1: Block diagram of contactless speed monitoring and displaying

The block diagram of the contactless is shown above. A 220V AC supply is fed to a transformer. The transformer is a Step down transformer and the voltage has been stepped down to 12 V AC. Then the supply is fed to the rectifier where the 12V AC supply is converted to 12V D.C voltage which is further fed to the main circuit. The sensor consists of two component IR diode and photodiode. The Sensor module works on the principle of Reflection of Infrared Rays from the incident surface. A continuous beam of IR rays is emitted by the IR LED. Whenever a reflecting surface (white/obstacle) comes in front of the Receiver (photo diode), these rays are reflected back and captured. Whenever an absorbing surface (Black/No Obstacle) comes in front of the Receiver, these rays are absorbed by the surface and thus unable to be captured. At each rotation the reflecting surface comes in front and a beam of ray is absorbed by the photodiode. The ray absorbed by the photodiode produces current in the form of a pulse which is fed to the microcontroller which counts the pulse i.e. it counts the number of rotations per minute. Finally the output from the microcontroller is displayed on a LCD. The final rpm is viewed by the LCD.

The circuit design as represented by the layout diagram is shown below

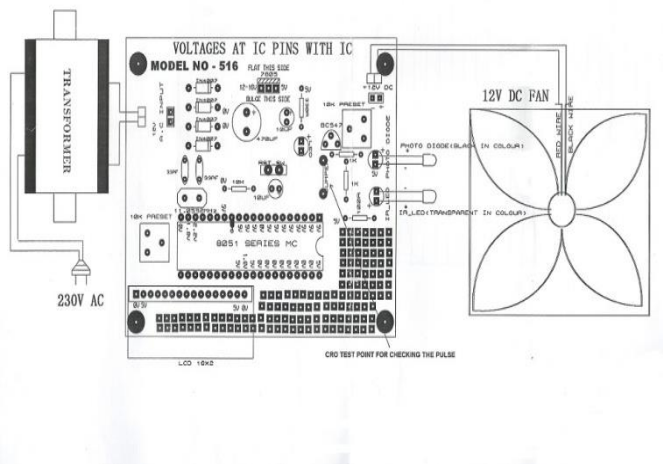

Fig -2: Layout diagram

#### 4. IMPLEMENTATION OF THE PRESENT TECHNIQUE:

We have applied this technique on a Brushless DC (BLDC) fan. We have attached a white strip on the rotating part of the BLDC fan. With the help of emission and absorption technique of our device we have measured the speed of a BLDC fan and the speed (in r.p.m) has been recorded as 2172 r.p.m. Further investigation for improvement of present technique is under way.

Further possible applications of the present techniques are as follows:

- a) This circuit can be used to calculate speed of rotating wheels, discs and motor shafts.
- b) This circuit can be used at places where direct contact with motor shafts or wheels is not possible to be made, as in case of vehicles and also in industrial machines.
- c) This circuit can be used at homes to check speed of small battery operated fans and other motor based devices.

d) Speed monitoring used in laser cutting process- Laser is used as a cutting tool in many industries where speed monitoring is very much necessary for best output.

In some lasers are used for labeling there also the speed monitoring is necessary.

### 3. CONCLUSIONS

We can monitor the speed (rpm) of any rotating body with the device, But have to attach the white strip in the rotating body. It is used in various applications because of its efficiency, quicker response and cheaper in cost. It is very simple to use.

### ACKNOWLEDGEMENT

Thanks are due to Prof Dr . Sukumar Chandra Konar and Prof. Amlan Chakraborty for their fruitful suggestion.

### REFERENCES

- [1] STEPHENSON, J.M; 'New low noise tachogenerator', Proc, IEE, 1969, 166, (11) pp.1981-1983.
- [2] STREATFIELD, C.G.; 'A digital tachometer using commercial counter', INT. J. Electr, Eng, Educ, 1971, 9, pp.217-220.
- [3] 'Digital Tachometer with Fast Dynamic Response Implemented by a Microprocessor', IEEE TRANSACTIONS ON INDUSTRY APPLICATIONS, 1983, 6, 1052-1056.
- [4] F.J: 'Practical instrumentation transducers' (Hayden, 1971). pp101-102.
- [5] 'Magnetic sensor for automotive application', Sensor and Actuators A 2001, 91, 2-6.