

Design and Analysis of Hydraulic Scissor Lift By FEA

Sabde Abhijit Manoharrao¹, Prof. Jamgekar R.S.²

¹ Student of Bharat Ratna Indira Gandhi College Of Engineering Solapur , Maharashtra, India

² Professor Department of Mechanical Engineering, Bharat Ratna Indira Gandhi College Of Engineering Solapur , Maharashtra, India

Abstract - A hydraulic pallet lift is a mechanical device used for various applications for lifting of the loads to a height or level. A lift table is defined as a scissor lift used to stack, raise or lower, convey and/or transfer material between two or more elevations. The main objective of the devices used for lifting purposes is to make the table adjustable to a desired height. A scissor lift provides most economic dependable & versatile methods of lifting loads; it has few moving parts which may only require lubrication. This lift table raises load smoothly to any desired height. The scissor lift can be used in combination with any of applications such as pneumatic, hydraulic, mechanical, etc. Lift tables may incorporate rotating platforms (manual or powered); tilt platforms, etc, as a part of the design. Scissor lift design is used because of its ergonomics as compared to other heavy lifting devices available in the market. The frame is very sturdy & strong enough with increase in structural integrity. A multiple height scissor lift is made up of two or more leg sets. As per the discussion with the concern person of DS Engineering, Pune, It is found that they are facing some problems regarding hydraulic scissor lift like job to be lifted are heavier which causes more deformations in hydraulic lift frame checking deformations & stresses induced in it is a major objective of this project. It is also found that weight of the present lift is high weight optimization is also prime objective of this project. As loading & unloading is repeated there may be chances of fatigue failure, to check the life of lift. Design & Analysis of the Hydraulic lift that should with stand maximum load without failure in working conditions. To check vibration of hydraulic lift during working time by modal analysis

1. INTRODUCTION:

The most common industrial lift is the hydraulic scissor lift table. This may seem like a complicated piece of equipment, but in actuality hydraulic lift tables are really very simple in design.

Hydraulic scissor lift tables are comprised of five major components:

Platform – This is the top of the lift table where lifted product sits. It can be supplied in a variety of sizes.

Base – This is the bottom of the structure that rests on the floor. It contains the track the scissor legs travel in.

Scissor legs – These are the vertical members that allow the platform to change elevation.

Hydraulic cylinder – The most common industrial scissor lifts are actuated by one, two, or three single-acting hydraulic cylinders. These allow the lift table to lift and lower.

Motor or Power Source – Most hydraulic scissor lifts are powered by either an electric or air motor. These provide power to the hydraulic pump which actuates the lift table.

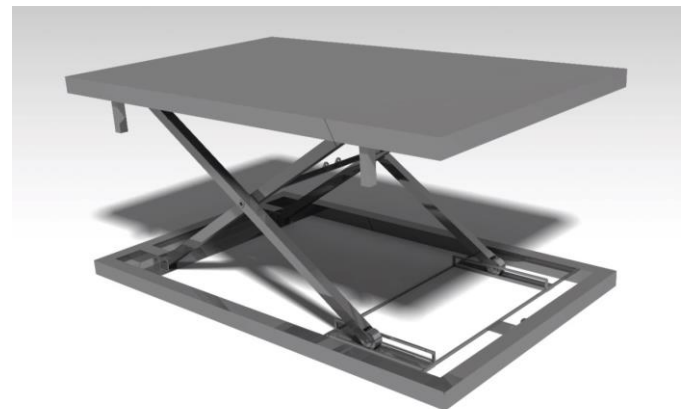

Fig. (1): Hydraulic Scissor Lift

Keywords- Analysis, Design, Hydraulic Lift, FEA

1.1 Hydraulic Lift Working:

A hydraulic lift table raises and lowers when hydraulic fluid is forced into or out of the hydraulic cylinder(s). As hydraulic fluid is forced into a cylinder, the cylinder strokes outward forcing the scissor legs apart.

Raising the Lift Table:

Since one end of both the inner and outer legs are connected to the base and platform, the platform rises vertically as the scissor legs open. The free end of the scissor legs are fitted with rollers that run in the base.

Any time a lift table is raised, it is being supported by a column of fluid. The lift table remains in a raised position because the fluid is held in the cylinder(s) by a simple check valve. A lift table's up speed is a function of the hydraulic pump and the motor that is turning it. The desired up speed and capacity to be lifted determine the amount of work the motor has to do, thus the horsepower required. If a lift table needs to move faster, it will take more horsepower. If a lift table has to have greater capacity, it will also take more horsepower.

Lowering the Lift Table:

The lift table is lowered by opening a down valve that allows fluid out of the cylinder at a controlled rate. This down valve is solenoid operated and a "normally closed" type valve, which means it stays closed until the electric solenoid is actuated. This feature prevents the lift table from lowering if there were a power failure. When the solenoid opens the down valve, the fluid returns to the reservoir.

The down speed of a lift table is a function of controlling how fast the fluid is allowed to leave the cylinder. This is done with a flow control (FC) valve. The FC valve is pressure compensated, which means it regulates the flow to a predetermined range whether the lift is loaded or empty. These FC valves are fixed rate or non-adjustable and typically the lift table's down speed is matched to lift table's up speed.

These types of lifts are used to achieve high travel with relatively short platform. Industrial scissor lifts & tilters are used for a wide variety of applications in many industries which include manufacturing, warehousing, schools, grocery distribution, military, hospitals and printing. The scissor lift contains multiple stages of cross bars which can convert a linear displacement between any two points on the series of cross bars into a vertical displacement multiplied by a mechanical advantage factor. This factor depends on the position of the points chosen to connect an actuator and the number of cross bar stages. The amount of force required from the actuator is also amplified, and can result in very large forces required to begin lifting even a moderate



Fig.(2): Hydraulic Scissor Lift during lifting the heavy loads.

amount of weight if the actuator is not in an optimal position. Actuator force is not constant, since the load factor decreases as a function of lift height.

Conventionally a scissor lift or jack is used for lifting a vehicle to change a tire, to gain access to go to the underside of the vehicle, to lift the body to appreciable height, and many other applications Also such lifts can be used for various purposes like maintenance and many material handling operations. It can be of mechanical, pneumatic or hydraulic type. The design described in the paper is developed keeping in mind that the lift can be operated by

mechanical means by using pantograph so that the overall cost of the scissor lift is reduced. In our case our lift was needed to be designed a portable and also work without consuming any electric power so we decided to use a hydraulic hand pump to power the cylinder Also such design can make the lift more compact and much suitable for medium scale work. Finally the analysis of the scissor lift was done in ansys and all responsible parameters were analyzed in order to check the compatibility of the design.

1.2 Types of Hydraulic Lifts:

- Classification based on the type of energy used
 - (a)Hydraulic lifts
 - (b)Pneumatic lifts
 - (c)Mechanical lifts
- Classification based on their usage
 - (a)Scissor lifts
 - (b)Boom lifts
 - (c)Vehicle lifts

1.3 Advantages of Hydraulic Lift:

A scissor lift, or commonly called as a table lift, is mainly used to lift people upwards with its criss-crossing foundation supporting beneath the platform. As the platform pulls itself together, it moves upright in the vertical direction and push the platform in accordance with the height and weight. These lifts can be controlled through hydraulic, pneumatic or mechanical power for height extension. Originally delivered in numerous sizes and shapes, it is designed and manufactured as an industrial lift, and has been customized for commercial and comprehensive purposes.

1. A scissor lift can be accessed to reach certain heights difficult to reach out. With a variety, larger prototypes can extend till 18.8 meters (62 feet).
2. They are very simple to operate and decreases tardiness and exhaustion amongst the operators.
3. By using a scissor lift, one avoids Repetitive Strain Injury (RSI) as it eliminates the requirement to bend and stretch.

4. Weight uplifting is distributed evenly while using a scissor lift.

5. Scissor lifts does not require any large containment places, but instead can be stored in minimum areas.

6. Scissor lifts differ on the basis of power utilization, and are categorized into hydraulic, pneumatic or mechanical model depending upon the necessities.

7. While they vary in sizes, platform sizes, styles, heights and vertical travel, they are bound to carry different volumes for dynamic working environment.

8. They are accessible and can be customized easily, such as adding a turntable for a rotational benefit or adding tilters to minimize the risk.

9. Scissor lifts are said to be portable or motionless, as required.

10. By using a scissor lift, you can save tremendous time and manual labor, which directly proposes a rise in production and increased employee interest.

11. With a versatile nature, they are easily adaptable with different terrains and climate.

With a vast variety to choose from, consumers will be satisfied with the type of work it delivers in less time. Being an economic tool, it can be discovered in almost every company. Easing the task of operators is what tools are delivered for, and creating a comfortable environment can result in an increased productive output. One of the many tools essential for manufacturing and stocking purposes, a scissor lift adds to the flexible functionality and productive ways to accomplish any task. With numerous benefits, it is tagged as one of the popular equipment used.

1.4. Applications of Hydraulic Scissor Lift

A scissor lift table has many useful purposes. The applications of a scissor lift table include a variety of things, but the platform is ultimately designed to help lift and raise heavier objects. The industrial lift is most often seen in behind the scenes of retail establishments and warehouses, although manufacturing engineers are always redesigning

the lift for various uses like lifting heavy vehicles as shown in following fig.



Fig. (3): Hydraulic Scissor Lift during lifting the heavy loads

These are some of the most commonly seen applications for scissor lifts:

Examples of What a Scissor Lift Table Can Do

1. The scissor lift table can raise a forklift so that maintenance to the underneath of the forklift can be performed.
2. By employing scissor lift tables in a warehouse, all heavy items can be lifted with ease. You can use it to stack boxes, pallets and other heavy materials.
3. Sheet metal is often stacked. The metal is usually too heavy for employees to try and lift for the stacking process. This is where a scissor lift table can help.
4. Distributaries often use scissor lift tables for the lifting of merchandise.
5. Scissor lift tables can be used to lift people and those in wheelchairs. By using a lesser capacity scissor lift, you can lift people for outdoor chores

such as cleaning gutters and windows. Those who use wheelchairs can use the lift to reach higher levels with less constraint.

6. In major cities, you will often see scissor lift tables used as platforms for maintenance and construction.
7. Some scissor lift tables are used as weight platforms to weigh machinery and other mechanisms.
8. Use the lift as a deck extension during a major renovation or project. Scissor lift tables can help you in any renovation or remodel. It is useful for allowing people to reach higher areas of a building.
9. Scissor lift tables can be designed to operate in different ways, but they can all be lowered and raised, but their main purpose will always be to lift. Designers and engineers of new models have to keep this in mind, no matter how outside-the-box they're looking to be with their developments.

1.5 Selection of Material:

It is necessary to evaluate the particular type of forces imposed on components with a view to determining the exact mechanical properties and necessary material for each equipment. A very brief analysis of each component follows thus:

- I. Scissors arms
- II. Hydraulic cylinder
- III. Top plat form
- IV. Base plat form
- V. Wheels

Scissors Arms: this component is subjected to buckling load and bending load tending to break or cause bending of the components. Hence based on strength, stiffness, plasticity an hardness. A recommended material is stainless steel.

Hydraulic Cylinder: this component is considered as a strut with both ends pinned. It is subjected to direct compressive force which imposes a bending stress which may cause

buckling of the component. It is also subjected to internal compressive pressure which generates circumferential and longitudinal stresses all around the wall thickness. Hence necessary material property must include strength, ductility, toughness and hardness. The recommended material is mild steel.

Top Platform: this component is subjected to the weight of the workman and his equipment, hence strength is required, the frame of the plat form is mild steel and the base is wood.

Base Platform: this component is subjected to the weight of the top plat form and the scissors arms. It is also responsible for the stability of the whole assembly, therefore strength. Hardness and stiffness are needed mechanical properties. Mild steel, SAE 1020, Inconel 600 is used.

2. PROBLEM STATEMENT:



Fig:(4); Fatigue Failure of Hydraulic Scissor lift



Fig:(5): Failure of Hydraulic Scissor lift due to maximum deformations

As per the discussion with the concern person of DS Engineering, Pune, It is found that they are facing some problems regarding hydraulic scissor lift like job to be lifted are heavier which causes more deformations in hydraulic lift frame which may causes failure at loading points. As loading & unloading is repeated there may be chances of fatigue failure, it is also found that weight of the present lift is high. Vibrations produced by lift during working are also more. Above images shows the failure zones of lift which are taken at workshop.

3.LITERATURE REVIEW:

[1] “Design, Manufacturing & Analysis of Hydraulic Scissor Lift”, Gaffar G Momin, et al

This Paper describes the design as well as analysis of a hydraulic scissor lift. Conventionally a scissor lift or jack is used for lifting a vehicle to change a tire, to gain access to go to the underside of the vehicle, to lift the body to appreciable height, and many other applications Also such lifts can be used for various purposes like maintenance and many material handling operations. It can be of mechanical, pneumatic or hydraulic type. The design described in the paper is developed keeping in mind that the lift can be operated by mechanical means by using pantograph so that the overall cost of the scissor lift is reduced. In our case our lift was needed to be designed a portable and also work without consuming any electric power so we decided to to use a hydraulic hand pump to power the cylinder Also such design can make the lift more compact and much suitable for medium scale work. Finally the analysis of the scissor lift was done in ansys and all responsible parameters were analyzed in order to check the compatibility of the design values

[2] “Design, Analysis and Development of Multiutility home equipment using Scissor Lift Mechanism”, Divyesh Prafulla Ubale, et al.

The conventional method of using rope, ladder lift getting person to a height encounter a lot of limitation (time and

energy consumption, comfortability, amount of load that can be carried etc.) also there may be a risk of falling down in case of ladders hence hydraulic scissors lift is designed to overcome all these difficulties. The main aim of this paper is design and analysis and to construct a multiutility home equipment for senior citizens so that they can carry their daily activities efficiently. Also the equipment should be compact and cost effective. Lifting height achieved by scissor mechanism is of 1 m from bottom level. Buckling and bending failure analysis of scissor is also done in this paper. With ceaseless development of science and technology, more and more new technologies are applied to lifting appliance design. This project aims at making equipment multifunctional, easy to use/operate, cost effective and portable so that it will be used conveniently at home and may be used in hospitals, hotels and other common places. Senior citizens face many problems to carry out their day to day activities, as this equipment is designed in such a way that (e.g. it is remote operated with battery) they can easily move in house and perform day to day activities. All safety considerations are taken into account while designing equipment. Scissor lifting mechanism is designed to lift person to desired height. A scissor lift mechanism is a device used to extend or retract a platform by hydraulic means. The Extension or displacement motion is achieved by the application of force by hydraulic cylinder to one or more supports. This force results in an elongation of the cross pattern. Retraction through hydraulic cylinder is also achieved when lowering of platform is desired.

[3] "Design and Analysis of Hydraulic Pallet System in Chain Conveyor", Setu Dabhi, et al,

This paper describes the design and analysis of hydraulic pallet system in a chain conveyor used in automobile industries for loading and unloading of materials .The system, consisting of a hydraulic power pack, a chain conveyor, a pallet system is automatically controlled with the help of PLC. Our aim is to design a feasible and a cost effective mechanism to lift the given load using hydraulic

actuation and listing merits of hydraulic actuations over pneumatic and servo actuation. The design module pallet along with mechanism used for balancing is design in CAD software CATIA and analyzed for variable loading in ANSYS .The design proposed is highly flexible with the manufactures requirement and its stability is analyzed under variable load. The result of the feasibility study showed a conspicuous shortening of working hours, and an alleviation of manual labor The manufacturer required a pallet system which is to be hydraulic actuated, rather than pneumatically or servo actuated. Comparing the three systems, we find pneumatic system rather advantageous over the other two. Merits of pneumatic system are listed below: Simplicity in design, Cost effective, Safety and reliability In spite of the above advantages, it was found that hydraulic system could handle more load as compared to the previous, and the back pressure so developed in hydraulic actuation could efficiently be handled as compared to pneumatic during movement of the pallet ,so as maintaining stability and reducing the amount of vibrations. Considering the involvement of the third system , where actuation of the pallet is via servo motors is out of question ,as its highly costly, requires frequent maintenance, and its load bearing capacity is also low as compared to others. The main advantage of using hydraulic system in our application over pneumatic other than the load bearing capacity is the fluid in hydraulic system is basically incompressible, hence it leads to minimum springing action. So even if the load on the pallet is non uniform, the actuators will balance the pallet in such a way so as to minimize the chances of over throwing the load. This sort of safety measure is difficult to achieve using pneumatic actuation, and even in case of uniform loading the vibration encountered is much more.

[4] "Finite Element analysis of Frame of Hydraulically Operated Beam Lifting Machine" S. B. Naik, et al

A special type of beam lifting device is designed for textile industries. The machine is hydraulically operated and is having two frames one horizontal and another vertical.

Horizontal frame is mounted with two telescopic cylinders used for beam lifting to required height. The mobility for the structure is provided by using castor wheels. Finite element analysis of the frames is done by ANSYS software considering the need of the textile industries, a special purpose machine has been designed to lift the beams in textile industries. The finite element analysis of the frame of this machine is done to get the idea of the stresses & deformation of the structure in order to modify the same if needed.

4.SCOPE OF WORK & OBJECTIVES

The scope and objectives of these stages are mentioned below.

a. Scope of work:

1. Study of present design of Hydraulic lift.
2. Identification and problem finding.
3. Collection of input data from research work.
4. Study of weight-dimensional parameters
5. Study of stresses, deformations in lift
6. Study of Vibration and impact resistance.
7. Study of Keeping of service life at different loading
8. Study of Reliable operation

b. Objectives:

1. As job to be lifted are heavier which causes more deformations in hydraulic lift frame checking deformations & stresses induced in it is a major objective.
2. Weight of the Present lift is high, Weight optimization is also prime objective of this project
3. As loading & unloading is repeated there may be chances of fatigue failure, to check the life of lift
4. Design & Analysis of the Hydraulic lift that should with stand maximum load without failure in working conditions.

5. To check vibration of hydraulic lift during working time by modal analysis

5 . METHODOLOGIES:

- Study of Present hydraulic lift design
- Taken practical input from industry
- Analytical Analysis
- Modeling by using CATIA V5 R20
- Analysis same model by using ANSYS for MS, SAE1020, Inconel
- Select one of best design
- Optimization of design
- Analysis using ANSYS
- Conclusion

5.1 Analytical analysis:

The maximum stress is occurring when lift is at highest position. Hence we did the analysis when weight is at highest point. General specification of lift is as follows when lift is at highest point.

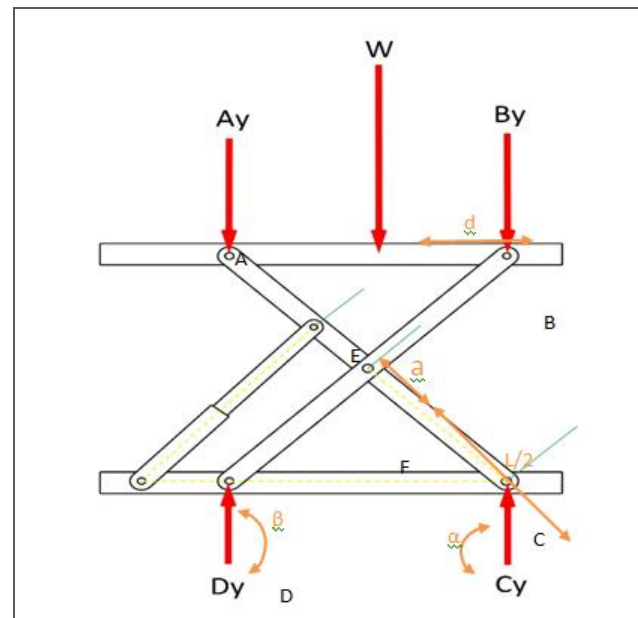

Fig.(6) Dimensions and Reactions of Forces

$$\text{Load} = W = 200 \text{ kg}$$

$$d = 834 \text{ mm}$$

$$L_2 = 1405 \text{ mm}$$

$$a = 130 \text{ mm}$$

$$L = 1684 \text{ mm}$$

$$\alpha = 33^\circ$$

$$\beta = 28.5^\circ$$

To find Reaction forces

Taking moment at point C

$$\sum M_c = 0$$

$$W.d - D_y.AB = 0$$

$$D_y = W.d/AB = W*834/1405 = 0.594 W$$

$$\sum F_{oy} = 0$$

$$D_y + C_y - W = 0$$

$$C_y = W - D_y$$

$$C_y = W - 0.594W$$

$$C_y = 0.406W$$

$$\sum F_{ox} = 0$$

$$P_x - F_x = 0$$

$$P_x = F_x$$

$$F_x = P.\cos \beta$$

$$\sum F_{oy} = 0$$

$$- D_y + P_y - F_y + C_y = 0$$

$$F_y = P_y + C_y - D_y$$

$$F_y = P_y + 0.406W - 0.594 W$$

$$F_y = P.\sin\beta - 0.188W$$

Taking moment about C

$$\sum M_c = 0$$

$$D_y.L.\cos\alpha - P_y.(L/2 + a)\cos\alpha + F_y.L/2.\cos\alpha - P_x.(L/2+a).\sin\alpha + F_x.L/2.\sin\alpha = 0$$

$$D_y.L.\cos\alpha - P.\sin\beta.(L/2 + a)\cos\alpha + F_y.L/2.\cos\alpha - P.\cos\beta.(L/2+a).\sin\alpha + F_x.L/2.\sin\alpha = 0$$

$$0.594W.L.\cos\alpha - P.\sin\beta.(L/2 + a)\cos\alpha + P.\sin\beta.L/2.\cos\alpha - 0.188W.L/2.\cos\alpha - P.\cos\beta.(L/2+a).\sin\alpha + P.\cos\beta.L/2.\sin\alpha = 0$$

$$0.594W.L.\cos\alpha - 0.188W.L/2.\cos\alpha - P.\sin\beta.(L/2 + a)\cos\alpha + P.\sin\beta.L/2.\cos\alpha - P.\cos\beta.(L/2+a).\sin\alpha + P.\cos\beta.L/2.\sin\alpha = 0$$

$$0.5W.L.\cos\alpha - P.a (\sin\beta.\cos\alpha + \cos\beta.\sin\alpha) = 0$$

By rule of geometry

$$(\sin\beta.\cos\alpha + \cos\beta.\sin\alpha) = \sin(\alpha + \beta)$$

$$P = \frac{0.5W.L.\cos\alpha}{a.\sin(\alpha + \beta)}$$

The highest stress will be at point where piston-cylinder is mounted to the arms i.e at point 'E'. Hence we are finding stress at point 'E'. For that we are going to consider arm 'AC' only for calculation.

At highest position of lift, the angle

$$\alpha = 33^\circ$$

$$\beta = 28.5^\circ$$

Find force by piston cylinder at highest position

$$P = \frac{0.5*2000*1684*\cos33}{130*\sin(33 + 28.5)}$$

$$P = 12362 \text{ N}$$

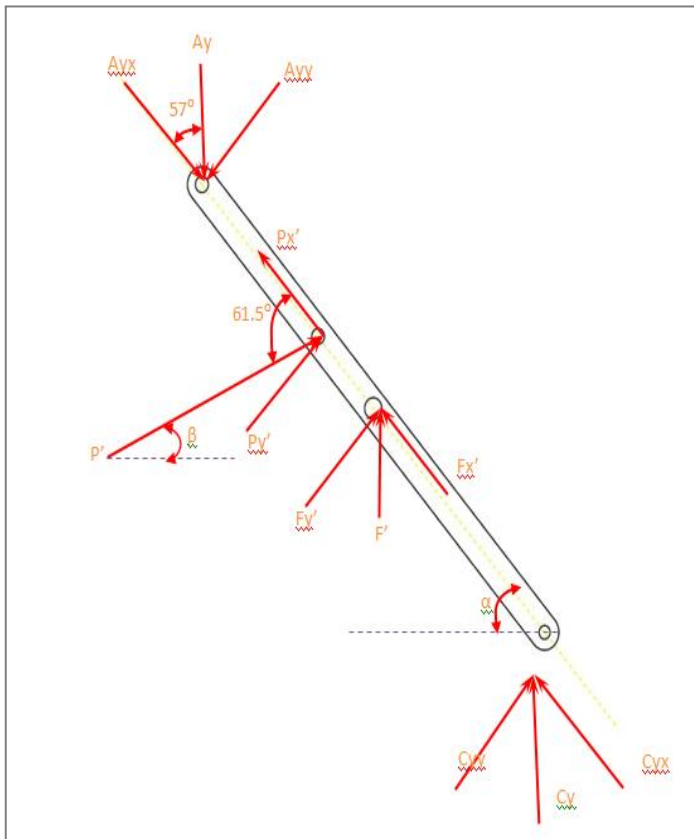

Fig. (7) Free Body Diagram of Arm

As we can see in free body diagram $A_y = D_y$ and $C_y = B_y$ but opposite in direction

From free body diagram

$$C_{yx} = C_y \cdot \cos 57 = 0.406W \cdot \cos 57 = 442.25 \text{ N}$$

$$C_{yy} = C_y \cdot \sin 57 = 0.406W \cdot \sin 57 = 681 \text{ N}$$

$$A_{yx} = A_y \cdot \cos 57 = D_y \cdot \cos 57 = 0.594W \cdot \cos 57 = 647.03 \text{ N}$$

$$A_{yy} = A_y \cdot \sin 57 = D_y \cdot \sin 57 = 0.594W \cdot \sin 57 = 996.34 \text{ N}$$

$$P_{x'} = P \cdot \cos 61.5 = 12362 \cdot \cos 61.5 = 5898.64 \text{ N}$$

$$P_{y'} = P \cdot \sin 61.5 = 12362 \cdot \sin 61.5 = 10863.94 \text{ N}$$

$$F_{x'} = -A_{yx} + P_{x'} + C_{yx}$$

$$F_{x'} = -647.03 + 5898.64 + 442.25$$

$$F_{x'} = 5690.86 \text{ N}$$

$$F_{y'} = -A_{yy} + P_{y'} + C_{yy}$$

$$F_{y'} = -996.34 + 10863.94 + 681$$

$$F_{y'} = 10548.6 \text{ N}$$

$$F' = \sqrt{[(F_{x'})^2 + (F_{y'})^2]}$$

$$F' = \sqrt{5690.86^2 + 10548.6^2}$$

$$F' = 11985.78 \text{ N}$$

➤ **Finding maximum stress and deformation**

1. **For Original lift model**

Shape = Hollow Square Channel

Material = Mild Steel

Outer side = $O = 50 \text{ mm}$

Inner side = $I = 40 \text{ mm}$

Thickness = 5 mm

Cross Section Area

$$A = O^2 - I^2$$

$$A = 50^2 - 40^2$$

$$A = 900 \text{ mm}^2$$

Compressive Stress

$$\sigma_n = \frac{F}{A} = \frac{A_{yx} - P_{x'}}{A} = \frac{647.03 - 5898.64}{900} = -5.84$$

MPa

Negative sign shows stress is compressive

$$\tau = \frac{F}{A} = \frac{A_{yy} - P_{y'}}{A} = \frac{996.34 - 10863.94}{900} = -$$

10.964 MPa

➤ **Equivalent stress**

$$\sigma_{eq} = \sqrt{(\sigma_n)^2 + \tau^2}$$

$$\sigma_{eq} = \sqrt{(5.84)^2 + 10.964^2}$$

$$\sigma_{eq} = 12.42 \text{ MPa}$$

➤ **Maximum deformation**

According to Hook's Law

$$E = \frac{\sigma \text{ Stress}}{\rho \text{ Strain}}$$

$$E = \frac{\sigma}{dl/L}$$

Where, dl is deformation

$$dl = \frac{\sigma * L}{E}$$

$$dl = \frac{12.42 * 1684}{2 * 10^5}$$

$$dl = 0.1045 \text{ mm}$$

➤ **Equivalent stress**

$$\sigma_{eq} = \sqrt{(\sigma_n)^2 + \tau^2}$$

$$\sigma_{eq} = \sqrt{(9.30)^2 + (17.495)^2}$$

$$\sigma_{eq} = 19.82 \text{ MPa}$$

➤ **Maximum deformation**

According to Hook's Law

$$E = \frac{\sigma \text{ Stress}}{\rho \text{ Strain}}$$

$$E = \frac{\sigma}{dl/L}$$

Where, dl is deformation

$$dl = \frac{\sigma * L}{E}$$

$$dl = \frac{19.82 * 1684}{2 * 10^5}$$

$$dl = 0.1688 \text{ mm}$$

2. For Optimized lift model

Shape = Hollow Square Channel

Material = Mild Steel

Outer side = O = 50mm

Inner side = I = 44mm

Thickness = 3 mm

Cross Section Area

$$A = O^2 - I^2$$

$$A = 50^2 - 44^2$$

$$A = 564 \text{ mm}^2$$

Compressive Stress

$$\sigma_n = \frac{F}{A} = \frac{Ayx - Pxl}{A} = \frac{647.03 - 5898.64}{564} = - 9.30 \text{ MPa}$$

Negative sign shows stress is compressive

$$\tau = \frac{F}{A} = \frac{Ayy - Pyl}{A} = \frac{996.34 - 10863.94}{564} = - 17.495 \text{ MPa}$$

3. Result Table:

Sr. no.	Equivalent Stress	Deformation
Original Lift	12.42 MPa	0.1045 mm
Optimized Lift	19.82 MPa	0.1688 mm

5.2 FEA ANALYSIS

➤ **CAD MODEL**



Fig.(8) CAD Model of Hydraulic Scissor lift

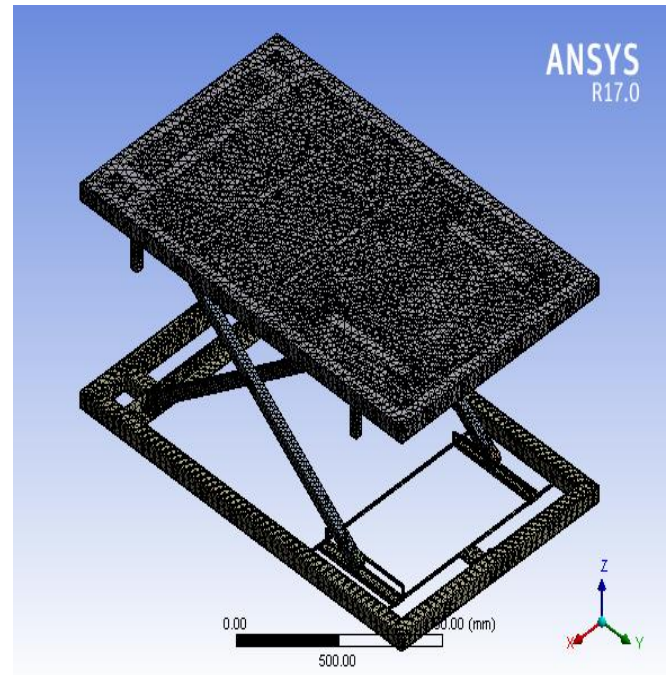

Fig.(9) FEA Model of Hydraulic Scissor Lift With Meshing.

➤ MESHING

➤ FEA MODEL

No. of Nodes	158431
No. of Elements	78141

➤ BOUNDARY CONDITIONS:

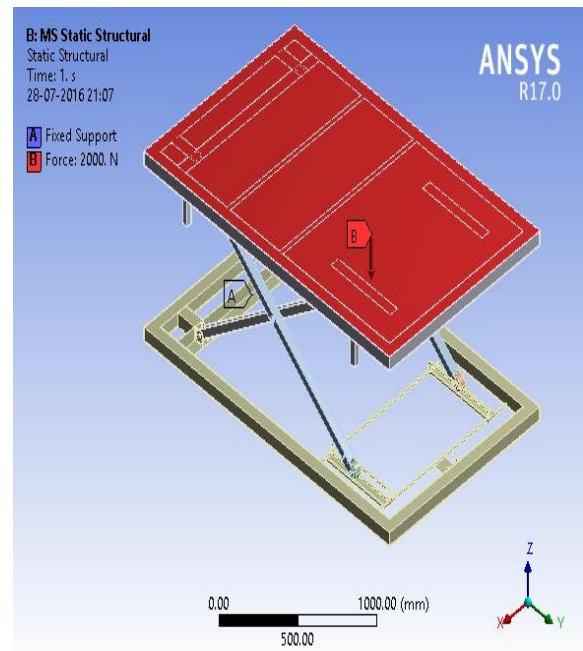

Fig.(10) FEA Model of Hydraulic Scissor Lift With Boundary Condition

5.3 ANALYSIS OF HYDRAULIC SCISSOR LIFT:

The analysis of lift has been carried out by using ANSYS 15 general purpose FEM software. The static analysis is done on the hydraulic lift

➤ **STATIC ANALYSIS OF HYDRAULIC LIFT:**

➤ **Procedure For Static Analysis in Ansys:**

1. Build the FE model as explained in above chapter
2. Define the material properties such as young's modulus and density etc.,
3. Apply boundary condition and pressures.
4. Solve the problem using current LS command from the tool.

5.3.1 STATIC ANALYSIS OF MS LIFT:

➤ **Properties of MS Lift:**

1. Young's modulus $E = 210 \text{ MPa}$
2. Poisson's ratio $\nu = 0.303$
3. Mass density $= 7860 \text{ kg/m}^3$
4. Damping co-efficient $= 0.008$

➤ **VON-MISES STRESS:**

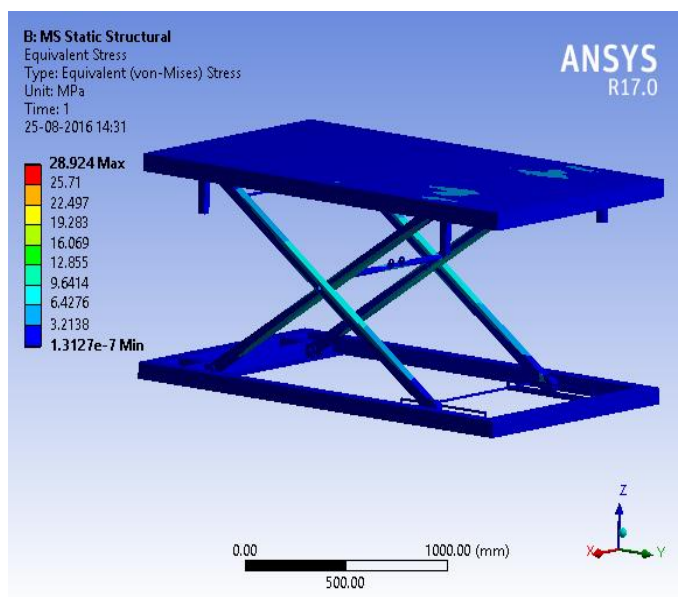

Fig.(11) Equivalent (Von-Mises) Stress of MS Hydraulic Scissor Lift, Mpa.

➤ **VON-MISES STRAIN:**

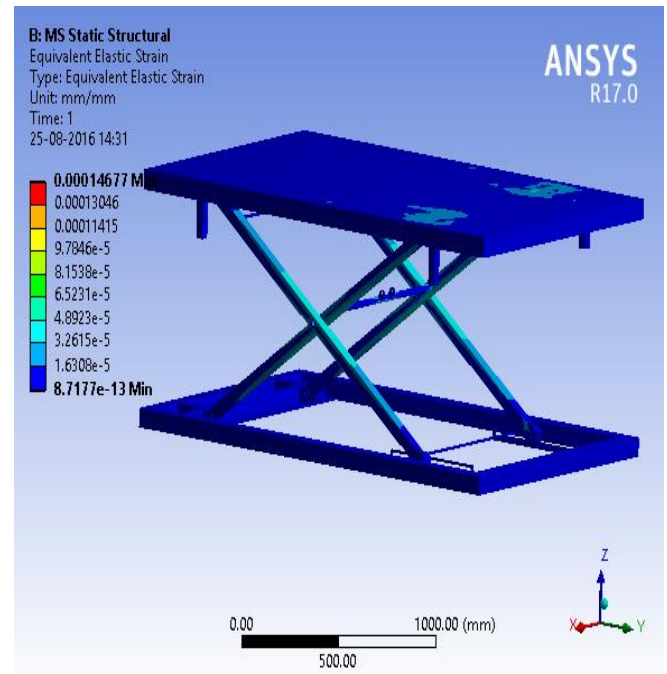

Fig.(12).Equivalent Elastic Strain of MS Hydraulic Scissor Lift.

➤ **TOTAL DEFORMATION:**

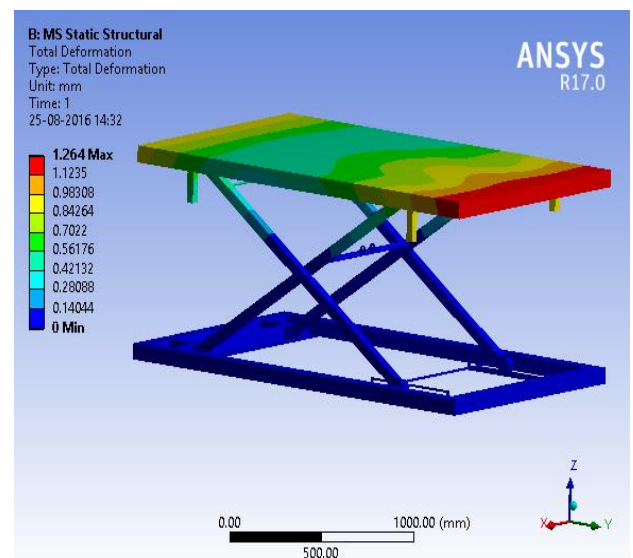

Fig.(13) Total Deformation of MS Hydraulic Scissor Lift, mm

➤ **LIFE:**

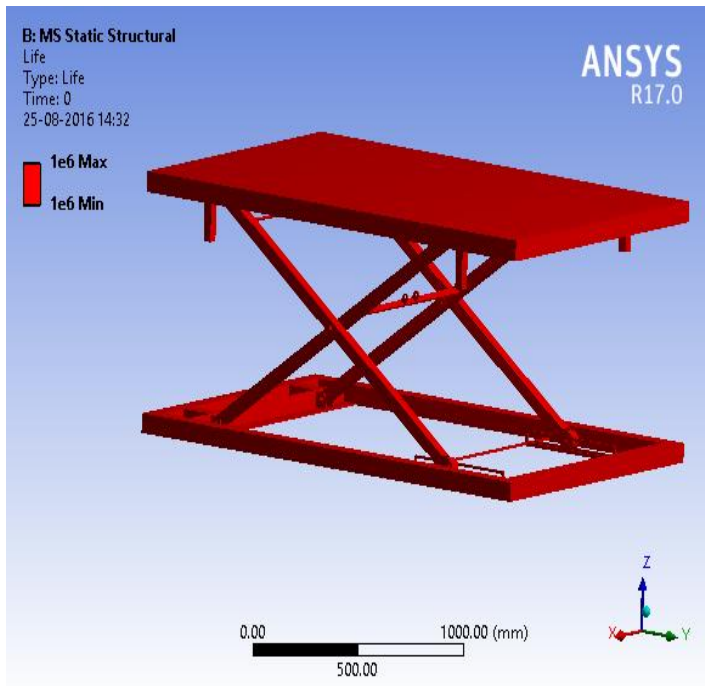

Fig.(14) Life Of MS Hydraulic Scissor Lift

5.3.2 STATIC ANALYSIS OF SAE 1020 LIFT:

➤ **Properties of SAE 1020**

Material	SAE1020
1. Young's modulus	2.05e+005 Mpa
2. Poisson's Ratio	0.3
3. Density	7.87e-006kg/mm ³
4. Tensile yield strength	350 Mpa
5. Tensile ultimate strength	420 Mpa

➤ **VON-MISES STRESS:**

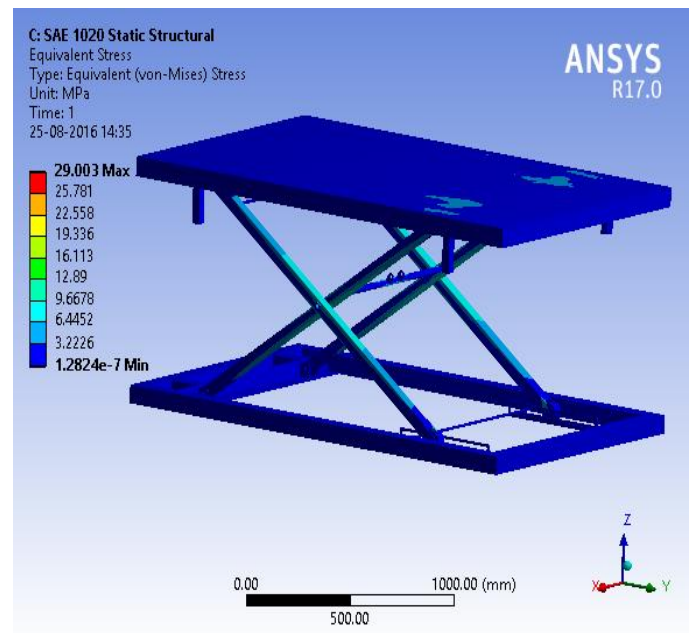

Fig.(15) Equivalent (Von-Mises) Stress of SAE 1020 Hydraulic Scissor Lift, Mpa

➤ **VON-MISES STRAIN:**

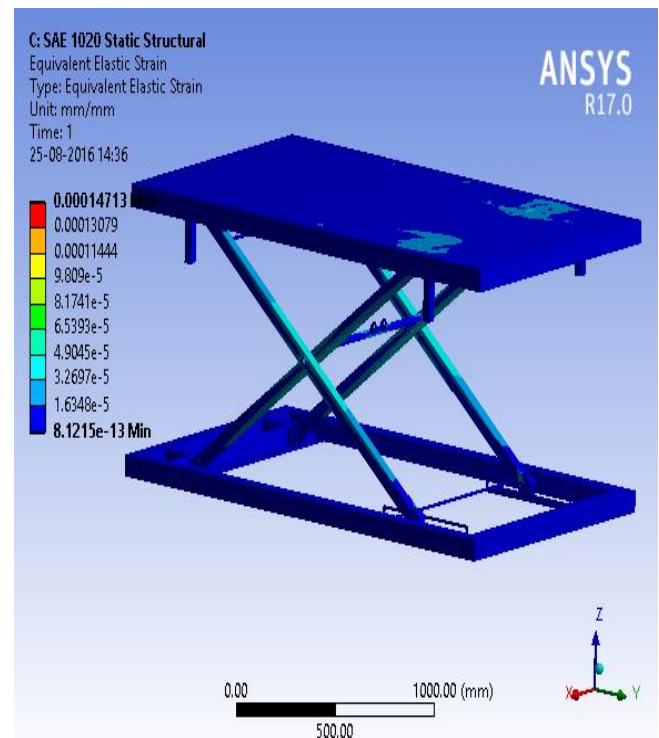

Fig.(16) Equivalent Elastic Strain of SAE 1020 Hydraulic Scissor Lift.

➤ **TOTAL DEFORMATION:**

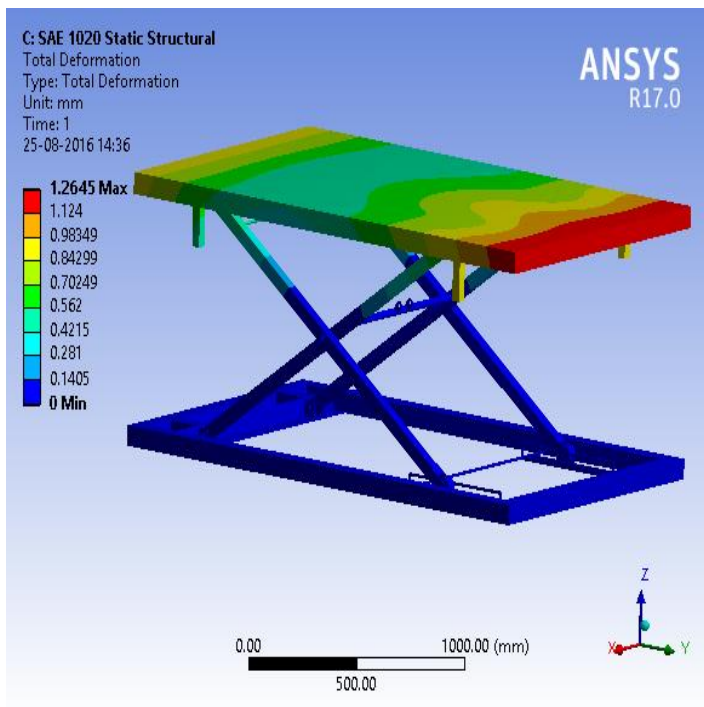

Fig.(17) Total Deformation of SAE 1020 Hydraulic Scissor Lift,mm

➤ **LIFE:**

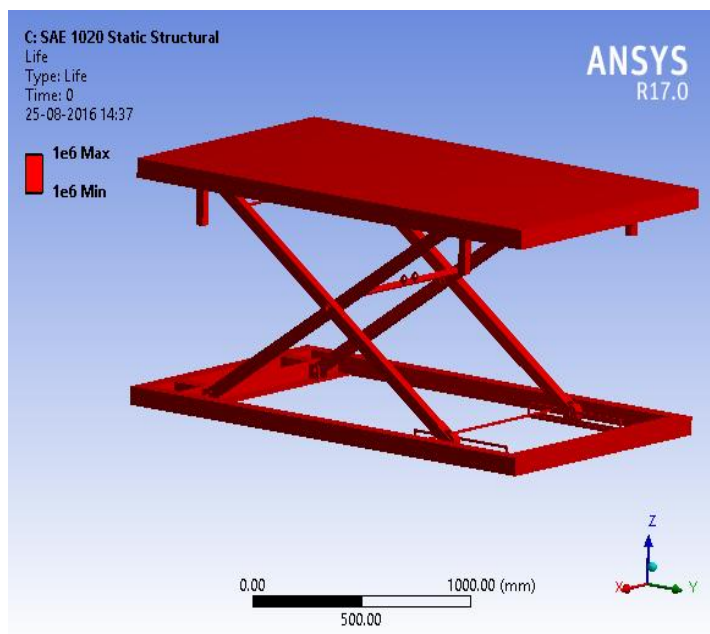

Fig.(18) Life of SAE 1020 Hydraulic Scissor lift

5.3.3 STATIC ANALYSIS OF INCONEL 600 LIFT:

➤ **VON-MISES STRESS:**

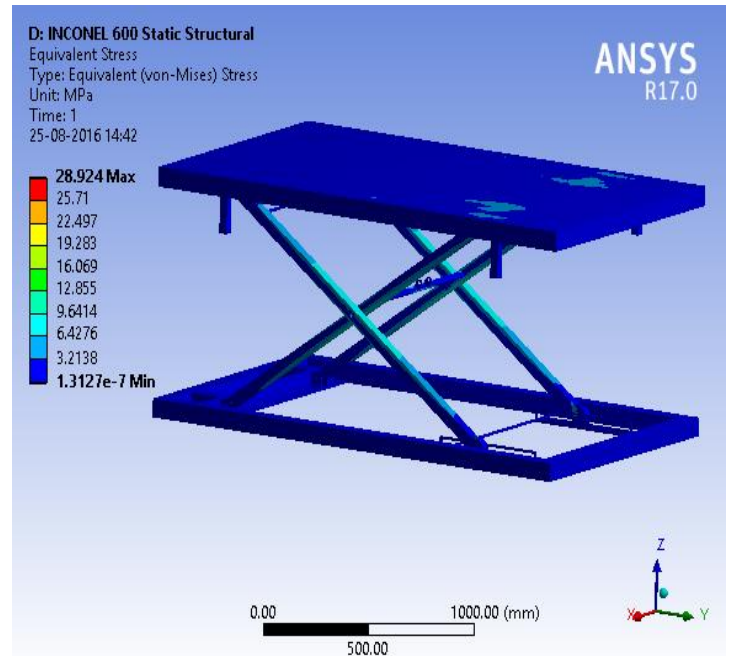

Fig.(19) Equivalent (Von-Mises) Stress of INCONEL 600 Hydraulic Scissor Lift,Mpa.

➤ **VON-MISES STRAIN:**

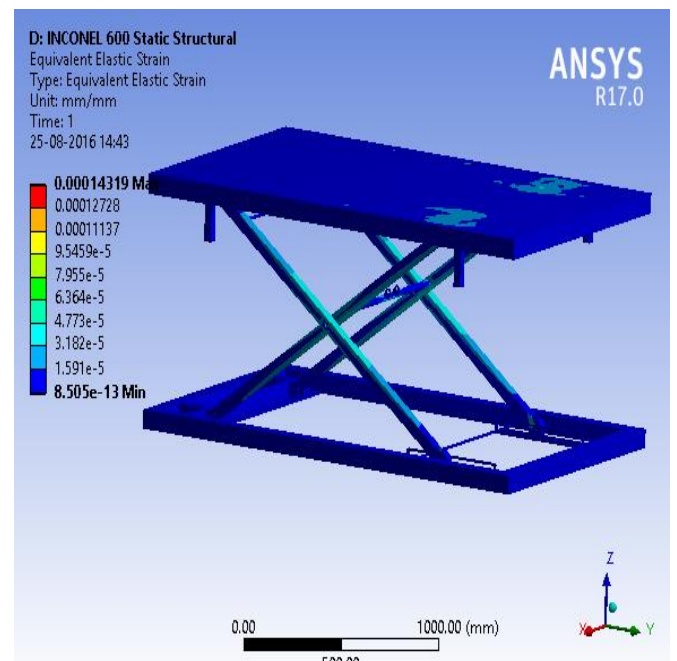

Fig.(20).Equivalent Elastic Strain of INCONEL 600 Hydraulic Scissor Lift.

➤ **TOTAL DEFORMATION:**

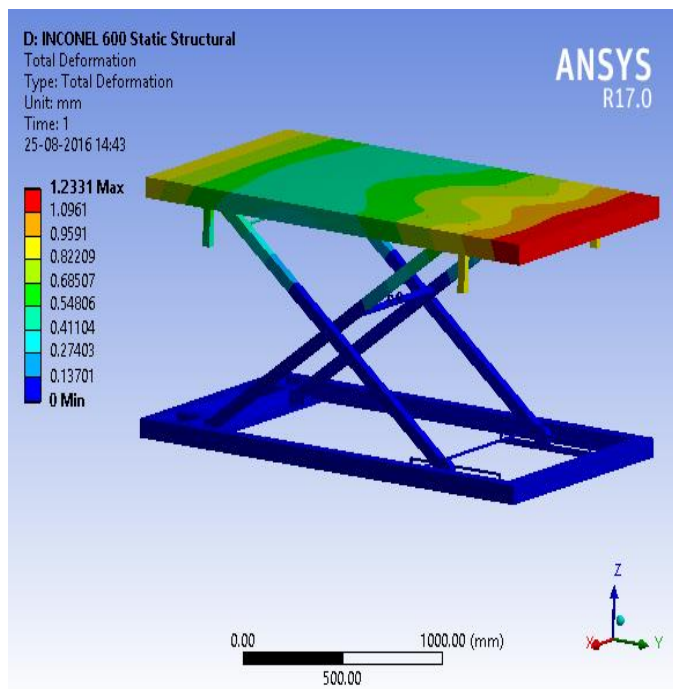

Fig.(21).Total Deformation of INCONEL 600 Hydraulic Scissor Lift, mm.

➤ **LIFE:**

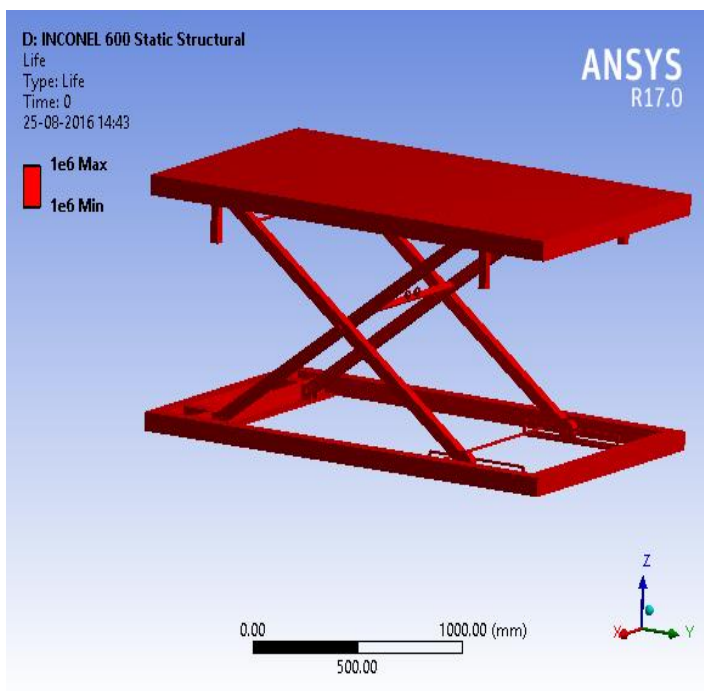

Fig.(22).Life of INCONEL 600 Hydraulic Scissor Lift.

5.4 Result And Discussion:

Material	MS	SAE 1020	INCONEL 620
STRESS(Mpa)	28.924	29.003	28.924
STRAIN	1.47E-04	1.47E-04	1.43E-04
DEFORMATION(mm)	1.26E+00	1.26E+00	1.23E+00
WEIGHT (kg)	354.53	355.44	381.18
MINIMUM FATIGUE LIFE (CYCLES)	1.00E+06	1.00E+06	1.00E+06

The maximum deformations induced in MS hydraulic lift is 1.26mm, which is in safe limits (1% of total span). Hence based on rigidity the design is safe, but if we compare deformations induced in SAE1020 (1.26), it is same as MS. If we compare corresponding deformations in Inconel it is 1.23 which has less deformation. The equivalent stress induced for three materials is almost same i.e. 28.924 Mpa, 29.003 Mpa, 28.924 Mpa which is less than the allowable stress (380Mpa).Hence the design is safe based on strength. Compare to MS lift SAE1020 is more rigid & ultimately strength of SAE1020 lift is increases due to its rigidity. Corresponding weight of each lift are shown in above table on observations it is found that existing weight of each lift are more so there is scope of weight optimization. During weight optimization we are not going to compromise the strength of lift. By modifying design of lift it is possible to optimize the weight. Fatigue life of existing lift is also can be increased by modifying design of lift. Failure of lift at localized area as discussed in problem statement can be improved by modifying the design of lift.

REFERENCES:

[1] "Design, Manufacturing & Analysis of Hydraulic Scissor Lift", Gaffar G Momin, et al, International Journal Of Engineering Research And General Science Volume 3, Issue 2, Part 2, March-April, 2015,ISSN 2091-2730

[2] "Design, Analysis and Development of Multiutility home equipment using Scissor Lift Mechanism", Divyesh Prafulla Ubale, et al, International Journal of scientific research and management (IJSRM), Volume-3, Issue-3, Pages- 2405-2408, 2015

[3] "Design and Analysis of Hydraulic Pallet System in Chain Conveyor", Setu Dabhi, et al, IJRET: International Journal of Research in Engineering and Technology eISSN: 2319-1163 ISSN: 2321-7308

[4] "Finite Element analysis of Frame of Hydraulically Operated Beam Lifting Machine" S. B. Naik, et al, International Journal For Technological Research In Engineering Volume 2, Issue 8, April-2015 ISSN (Online): 2347 - 4718

[5] Scissor Lift Tech Handbook, Omni metacraft