

Analytical study of solid flat slab and voided slab using ANSYS Workbench.

Mr Yadav Jaideep Purushottam¹, Prof Tambe Yogesh Hemantkumar²

¹Student : Civil Engineering department

NOVA College of Engineering and Technology

Jafferguda, Batasingram Village, Hayath Nagar Mandal, R. R. Dist. - 501512

jaideepyadav84@gmail.com

² Assistant Professor : Civil Engineering department

SVPM COE Malegaon Bk Tal: Baramati

Dist Pune.State : Maharashtra India

yogeshtambe619@gmail.com

Abstract – Slab is largest member which consumes concrete and when load acting on the slab is large or clear span between columns is more, the slab thickness is increasing. It leads to consume more material such as concrete and steel due to that, self-weight of slab is increased. To avoid these disadvantages various studies are carried out and researchers suggest voided slab system. Reinforced concrete slab with plastic voids is a new and innovative type of structural, concrete slab system developed to allow for lighter selfweight of the structure while maintaining similar load carrying capacity of a solid slab. In this study the design process for plastic voided slab is compared with reinforced concrete solid flat slab through a design comparison of typical bays of 4.54 m by 4.54 m (15 feet by 15 feet), 6.05 m by 6.05 m (20 feet by 20 feet), 7.57 m by 7.57 m (25 feet by 25 feet) and 9.08 m by 9.08 m (30 feet by 30 feet) with the same thickness of 0.25 m (10 inch). The solid flat slab design process follows the provisions made in the ACI 318-11 and the plastic voided slab design process is modified from the Bubble Deck Design Guide for compliance with BCA using AS3600 and Euro code 2. The various parameters like total bay weight, flexural reinforcement, solid perimeter, moment capacity of the voided slab and solid flat slab are calculated to compare both the systems and material-cost analysis is carried out to suggest the economical slab system. Also, the finite element analysis of the slab panels has been carried out by using ANSYS Workbench 14.5 to find out the deformation. The obtained results of deformation should be checked for live load and long-term deformation as per ACI 318-11. The primary objective of the work is to obtain optimum slab system with the above stated parameters.

Key Words: Solid Flat Slab, Voided Slab, Total Deformation, Long term deflection and live load deflection

1. INTRODUCTION

The Bubble Deck slab is a revolutionary biaxial concrete floor system developed in Europe in 1990's by Jorgen Breuning. The traditional Bubble Deck technology uses spheres made of recycled industrial plastic to create air voids while providing strength through arch action. This results in a dramatic reduction of dead weight by as much as 35-40% allowing much longer spans and less supporting structure than traditional solutions. Hence, the Bubble Deck has many advantages as compare to traditional concrete slab such as lowered total cost, reduced material use, enhanced structural efficiency, decreased construction time and is a green technology. It gains much of attention from engineers and researchers from the world. But, while designing a reinforced concrete structure, a primary design limitation is the span of the slab between columns. Designing large spans between columns often requires the use of support beams or varies thick slabs thereby increasing the weight of the structure by requiring the use of large amounts of concrete. Heavier structures are less desirable than lighter structures in seismically active regions because a larger dead load for a building increases the magnitude of inertia forces the structure must resist as large dead load contributes to higher seismic weight. Incorporating support beams can also contribute to larger floor-to-floor heights which consequently increases costs for finish materials and cladding. A new solution to reduce the weight of concrete structures and increase the spans of two-way reinforced concrete slab systems was developed in the 1990s in Europe and is gaining popularity and acceptance worldwide. Plastic voided slabs provide similar load carrying capacity to traditional flat plate concrete slabs but weigh significantly less. This weight reduction creates many benefits that should be considered by engineers determining the structural system of the building. Plastic voided slabs remove concrete from non-critical areas and replace the removed concrete with hollow plastic void formers while achieving similar load capacity as solid slabs.

2. OBJECTIVES OF PAPER

1. To analyze both the slab systems under same loading condition in ANSYS Workbench 14.5 to find out the total deformation.
2. To check the range of deformation is in the permissible limit as per ACI 318-11.

3. MATERIAL PROPERTIES OF SLAB MODEL

Table -1: Material properties

| Sr. No. | Name of Material | Property | Value |
|---------|------------------|---------------------------|------------------------|
| 1 | Steel | Modulus of Elasticity (E) | 200000 MPa |
| | | Density (ρ) | 7850 kg/m ³ |
| | | Poisson's Ratio (μ) | 0.3 |
| 2 | Concrete | Modulus of Elasticity (E) | 22361 MPa |
| | | Density (ρ) | 2308 kg/m ³ |
| | | Poisson's Ratio (μ) | 0.18 |
| 3 | HDPE Balls | Modulus of Elasticity (E) | 1035 MPa |
| | | Density (ρ) | 970 kg/m ³ |
| | | Poisson's Ratio (μ) | 0.4 |

4. PARAMETRIC STUDY

The primary goal of the study is to compare the relative weight of a plastic voided slab to the relative weight of a solid flat slab. Many parameters must be considered when designing a concrete slab. For a comprehensive comparison between two-way slabs and plastic voided slabs, a study must consider not only different bay sizes, but also span conditions and different weights. However, the purpose of this study is to provide a quick, illustrative comparison between solid flat slabs and plastic voided slabs. As a result, the two slab systems are compared by designing each for four different bay sizes. The four bay sizes are 15 feet by 15 feet (4.54 m by 4.54 m), 20 feet by 20 feet (6.05 m by 6.05 m), 25 feet by 25 feet (7.57 m by 7.57 m), 30 feet by 30 feet (9.08 m by 9.08 m). Each bay was designed as an interior span with no support beams which is typical for flat plates. An interior span was chosen since the majority of the structure is an interior span condition for buildings. The specified 28-day compressive strength of the concrete used for the study is 4000 pounds per square inch (27,580 kPa) and the yield strength of the reinforcing steel is 60,000 pounds per square inch (413,685 kPa). Square columns with 16-inch (40.6 cm) dimensions are used for all bays. Superimposed loads were also constant across each design. The self-weight for each design varied based on the type and thickness of the slab. A superimposed dead load of 20

pounds per square foot (0.96 kPa) and a live load of 80 pounds per square foot (3.83 kPa) were used to represent loads similar to a generic commercial building.

Deformation of Slab Using ANSYS Workbench 14.5

Deformation is the change in the shape of a body caused by the application of a force and proportional to the stress applied within the elastic limits of the material. The finite element analysis of the slab panels has been carried out using ANSYS workbench 14.5 program to find the deformation of both the slab systems under the same loading conditions. The dead load intensity varies as the span of slab increases and superimposed dead load of 20 psf is considered for all slab panels. The live load intensity of 80 psf is constant for all bay sizes. The slab panel is supported at its corner on four columns on which uniformly distributed load is applied for finding the corresponding deformation of the slab panel. Final design of voided slab projects almost always incorporates 'rigorous' deflection checking using FE modeling with modified element properties to take account of cracked section properties and long-term material effects. This technique is well known to produce more accurate results and these generally produce more favorable results for voided slabs compared with simplistic calculations. As per the provisions made in ACI 318-11, Check for deflection due to live load and long-term deflection has been studied for the solid flat slab and voided slab system to obtain its structural efficiency.

Table -2: Overview of Parametric Study

| Span | Slab Weight (psf) | | Live Load (psf) | Thk. (inch) | 28-Day Comp Stren gth of Concrete (kPa) | Yield Strength of Steel (kPa) |
|---------------|-------------------|-------------|-----------------|-------------|---|-------------------------------|
| | Solid flat slab | Voided slab | | | | |
| 15 ft x 15 ft | 75 | 50 | 80 | 10 | 27,580 | 413,685 |
| 20 ft x 20 ft | 100 | 65 | | | | |
| 25 ft x 25 ft | 125 | 80 | | | | |
| 30 ft x 30 ft | 150 | 95 | | | | |

Deflection due to Live Load: (ACI 318-11 Table 9.5 b)

$$\Delta_{L,L} = \Delta_{u \max} \times L.L / (1.2 D.L + 1.6 L.L) < (L/360)$$

Long-term Deflection: (ACI 318-11 9.5.2.5)

$$\Delta_{(3D.L+L.L)} = \Delta_{u \max} \times (3D.L + L.L) / (1.2 D.L + 1.6 L.L) < (L/180)$$

| Span | Slab Type | $\Delta_{u,max}$ (mm) | Deflection due to L.L (mm) | Permissible Deflection due to L.L (mm) | Long-term Deflection (mm) | Permissible Long-term Deflection (mm) |
|---------------|-----------------|-----------------------|----------------------------|--|---------------------------|---------------------------------------|
| 15 ft x 15 ft | Solid flat slab | 0.85 | 0.28 | 12.62 | 1.28 | 25.23 |
| 20 ft x 20 ft | Solid flat slab | 3.40 | 1.01 | 16.82 | 5.50 | 33.64 |
| 25 ft x 25 ft | Solid flat slab | 10.93 | 2.90 | 21.02 | 18.64 | 42.05 |
| 30 ft x 30 ft | Solid flat slab | 19.34 | 4.66 | 25.23 | 34.36 | 50.46 |

Solid Flat Slab Model (15 ft x 15 ft)

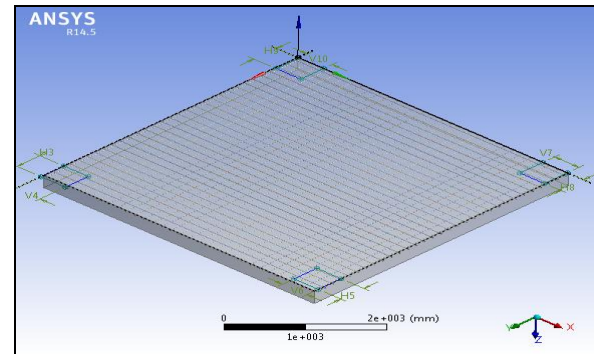

Fig.No.1: Solid Flat Slab Model

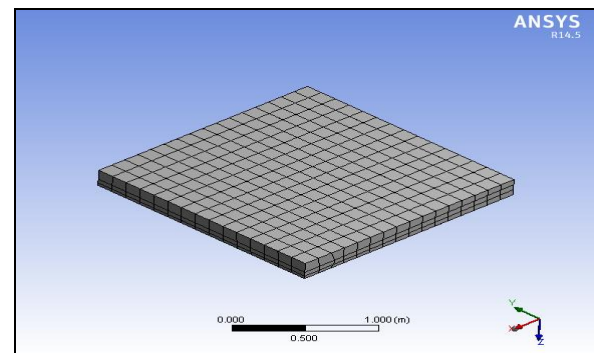

Fig.No.2: Meshing of Solid Flat Slab

Table No.3: Deflection due to Live Load and Long-Term Deflection (Solid flat slab)

| Span | Slab Type | $\Delta_{u,max}$ (mm) | Deflection due to L.L (mm) | Permissible Deflection due to L.L (mm) | Long-term Deflection (mm) | Permissible Long-term Deflection (mm) |
|---------------|-------------|-----------------------|----------------------------|--|---------------------------|---------------------------------------|
| 15 ft x 15 ft | Voided slab | 1.39 | 0.46 | 12.62 | 2.11 | 25.23 |
| 20 ft x 20 ft | Voided slab | 4.93 | 1.45 | 16.82 | 7.98 | 33.64 |
| 25 ft x 25 ft | Voided slab | 15.84 | 4.20 | 21.02 | 27.01 | 42.05 |
| 30 ft x 30 ft | Voided slab | 28.04 | 6.76 | 25.23 | 49.83 | 50.46 |

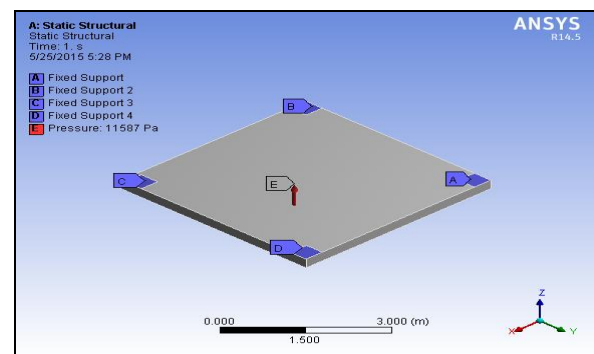

Fig.No.3: Loading Arrangement of Solid Flat Slab

Table No.4: Deflection due to Live Load and Long-Term Deflection (Voided slab)

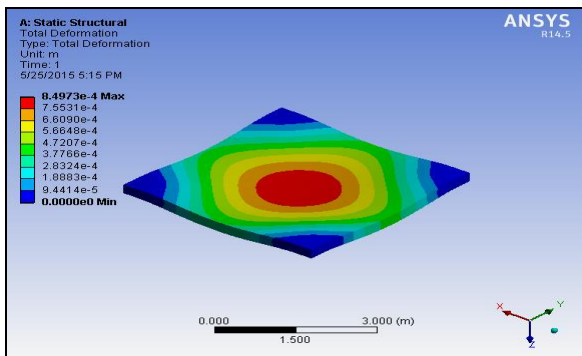

Fig.No.4: Deformation of Solid Flat Slab

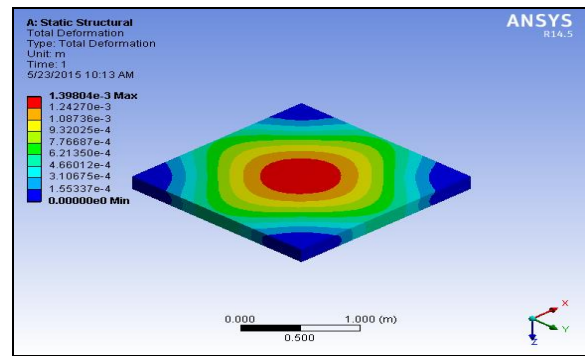

Fig.No.7: Deformation of Voided Slab

Voided Slab Model (15 ft x 15 ft)

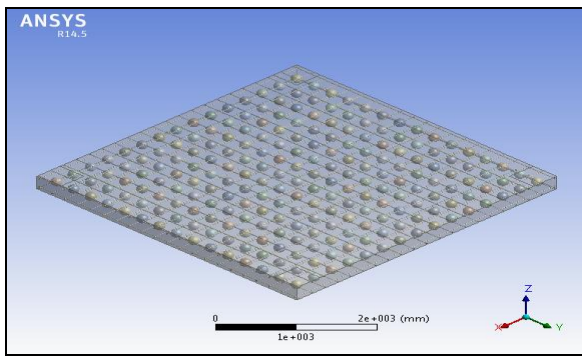

Fig.No.5: Voided Slab Model

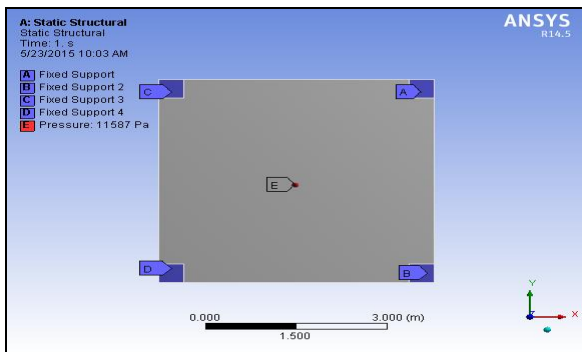

Fig.No.6: Loading Arrangement of Voided Slab

5. CONCLUSIONS

The deformation of both slab systems under same loading condition is calculated by using finite element analysis in ANSYS Workbench 14.5. The deformation due to live load and long-term deformation of solid flat slab and voided slab is in the range of permissible limits as per provisions made in ACI 318-11. Hence according to the structural efficiency point of view the voided slab shows good agreement.

REFERENCES

1. A. M. Ibrahim, N. K. Ali, (2013) "Flexural Capacities of Two-way Reinforced Concrete Bubble Deck slabs of Plastic Spherical Voids", Diyala journals of Engineering Sciences, Vol. 06, No. 02, pp. 9 - 20.
2. AS 3600-2001, published by Standards of Australia.
3. B.K. Bakht, L.G. Jaeger, M.S. Cheung and A.A. Mufti, (1981) "The State of the art in Analysis of Cellular and Voided Slab Bridge" Can. J. Civ. Eng., Vol. 8, pp. 376-391.
4. Bubble Deck Design Guide; the Biaxial Hollow Deck. Unpublished manuscript (2010).
5. Bubble Deck's U.S. Debut. Kirkland, WA: Bubble Deck North America. (2012).
6. Bubble Deck UK Head Office, Bubble Deck Voided Flat Slab Solution, Technical Manual and Documents, (2006).