

# An Advanced Automatic Wireless Monitoring & Controlling for Digital Door Lock System

Vaibhav V. Deshmukh<sup>1</sup> Amit V. Raut<sup>2</sup>

*1 Department of Electronics Engineering, RTM Nagpur University, Maharashtra, India*

*2 Department of Electronics & Communication Engineering, RTM Nagpur University, Maharashtra, India*

\*\*\*

**Abstract** - This project presents the design and implementation of microcontroller based high security purpose digital door lock system. Nowadays, due to the increasing rate of crime and insecurity, there is an immediate need to design a door lock system that takes proper measure to prevent intrusion, unwanted and unauthorized user. To solve these problems associated with other security door system, the project uses a computer system running on visual basic (6.0), GSM modem, RFID and AT89C2051 microcontroller as its main components to control the door. Everyone wants to be as secure as possible. An access control for doors forms a vital link in security chain. GSM Modem is used to communicate and respond to remote commands and those commands are sent to the controller. It consists of RFID detector on main door which sense the user ID card and if it match then main door will open and GSM modem send password on user mobile. The password is different for different times. The system has a keypad mounted on locker by which the password can be entered through it. When the password equals with password stored in the memory then locker is opened. The user get three chances to open the door if one fail to open the locker in three time automatically main door will closed and alarm will sound and GSM modem call main authority. The motor driver circuit is used to open and to close the door.

**KEYWORDS:** Security, Microcontroller, GSM (Global System Mobile), VB (Visual Basic), RFID (Radio Frequency Identification)

## 1. INTRODUCTION

Nowadays, various types of control systems have been designed to prevent access to unauthorized user. The main reason for providing locks for our buildings like home, office, church, school, banks, etc is for security of our lives and property. Moreover, it is expected that one of the main factors that cause the crimes derive from the owner of the house itself, such as carelessness and irresponsible behavior. Thus, it is very important to have a stress less and convenient means of achieving this purpose. Home security has been a major issue of concern

because of the increase in crime rate and everybody wants to take proper measure to prevent intrusion or unauthorized user. Today people are not very concern about safety of their premises. For an example the laboratories in the college are not safe enough because no safety procedures taken and the intruder can easily steal the valuable thing in the lab. The project that was built consists of hardware and software implementation. The project will have locking system that will activate by sending the right SMS to the system. If there is need of lab, the authorized people open it. Besides, this project will use the microcontroller in order to interface or communicate between the input signal and door lock circuit.

### 1.1 Problem Statements

- The previous lock methods have proven to be a bit unsatisfactory in one way or the other. Though, some have advantages outweighing the disadvantages while others have much more disadvantages.
- Due to the fact that live and property may be at stake, it is important to always have a reliable lock system, putting into consideration the high rate of crime and insecurity.
- Most door lock systems also require carrying external lock devices which complete the system; this may include keys, cards, remote controls, etc. On losing any of these devices, one may need to change the lock system in order to apply precaution(s) in case they have fallen into wrong hands.
- We all are aware of the fact that there has been a sharp increase in criminal offences like theft, robberies, assaults, murders etc in the recent past that is affecting our society on a large scale. So the requirement for a well equipped home security system is definitely on the rise.
- Also, due to the rapid growth in computer, GSM control system and technology advancement in general, it may be seen worthwhile to move with the recent trends either privately-in our homes or in our establishments.

## 1.2 Objectives

- To develop an automatic electronic based project that could act as a tool that able to help users to become more alert to verify their own safety.
- To design a high secured security door lock system that ease problems of unauthorized duplication of keys or access cards.
- To give user more secure yet cost-efficient way of a door locking-unlocking system.
- To design and construct a security door lock system with an alarm system that alert the user if a wrong code is entered more than the administered number of error counts.
- To design a security door lock system that will enable us exercise other numerous benefits associated with our mobile phones and computer system to investigate the feasibility and efficiency of implementing GSM as a method of communication.

## 1.3 Project Scope

This project will concentrate at the short messaging system i.e. SMS in order to open the door. The SMS signal coming from the mobile hand phone need to be identify in order to connect with the controller. The project will, have software and hardware work implementation. As mentioned above all the developments in door lock system, our project is somewhat easy to implement with high security and can be implemented in various industrial as well as in commercial sectors. To control access, a door must be modified in some manner to provide signals to the system to let it know whether or not the door is to be open or close, prohibiting passage of unauthorized persons. Simple access control is frequently used by corporate organizations and firms to limit access to their facilities, eliminating the need for a guard.

## 2. SYSTEM DESIGN

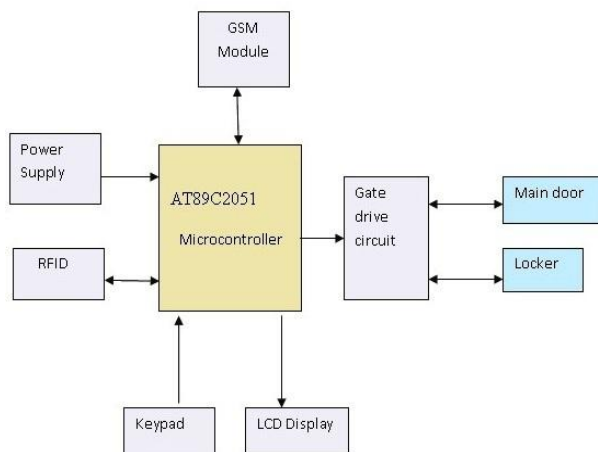

Figure 2.a. Block Diagram of digital door lock

The figure 2.a. shows the block diagram and the figure 2.b. shows the flowchart of the project wireless access monitoring and controlling system for digital door lock system.

## 2.1 AT89C2051 Microcontroller

The AT89C2051 is a low-voltage, high-performance CMOS 8-bit microcomputer with 2 Kbytes of Flash programmable and erasable read only memory (PEROM). The device is manufactured using Atmel's high density non-volatile memory technology and is compatible with the industry standard MCS-51 instruction set and pin out. By combining a versatile 8-bit CPU with Flash on a monolithic chip, the Atmel AT89C2051 is a powerful microcomputer which provides a highly flexible and cost effective solution to many embedded control applications.

The AT89C2051 provides the following standard features: 2 Kbytes of Flash, 128 bytes of RAM, 15 I/O lines, two 16-bit timer/counters, five vector two-level interrupt architecture, a full duplex serial port, a precision analog comparator, on-chip oscillator and clock circuitry.

## 2.2 RFID

Radio frequency identification (RFID Sensor R315A) is a general term that is used to describe a system that transmits the identity (in the form of a unique serial number) of an object wirelessly, using radio waves. RFID technologies are grouped under the more generic Automatic Identification (Auto ID) technologies.

RFID technology is based on bi-directional radio frequency communication between a base station and an ID tag or badge attached to the person or object to be tracked. The base station consists of a PC or some other microprocessor systems equipped with read/write unit. The tag consists of an antenna, some control circuitry and memory in which ID information is stored. The memory may be read only, i.e. the information stored in that is unalterable, or read/write, i.e. the information can be overwritten or added to the memory by the user. The fig below shows a RFID system with read only tag.

## 2.3 Gate Motor Drive Circuit for Main Door And Locker

The circuit of Gate Motor Drive Section is mainly consists of TIP122 and TIP127, Parallel Connector 25 Pin, Transistor BC547, AM5858 Motor. The AM5858 is a five-channel BTL driver IC for driving the motors and actuators such as used in DVD player. Two of the channels use current feedback to minimize the current phase shift caused by the influence of loading inductance. The motor

can be used in Applications like BTL driver for CD, CD-ROM and DVD.

### 2.4 GSM module

The GSM modem is a specialized type of modem which accepts a SIM card operates on a subscriber’s mobile number over a network, just like a cellular phone. Basically, it is a cell phone without display. We are using GSM module for transmitting password in form of SMS to user device. GSM Module plays important role as communication module.

### 2.5 Keypad and LCD Display

Keypad consist of numerical or alphabetical or both keys. Here we are using LCD display will show password that user will enter. The keypad and LCD are very important part of this project.

### 2.6 Power Supply

The power supply section is the important for any electronics circuits. The term power supply is provided in three section of the project, which is discussed in below.

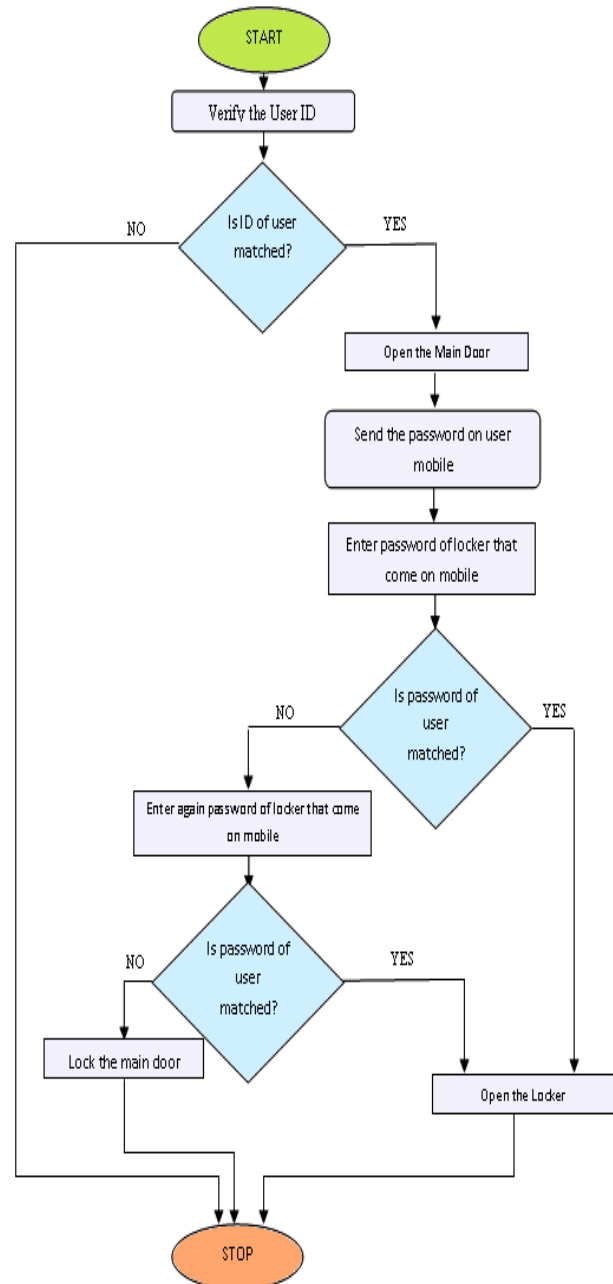
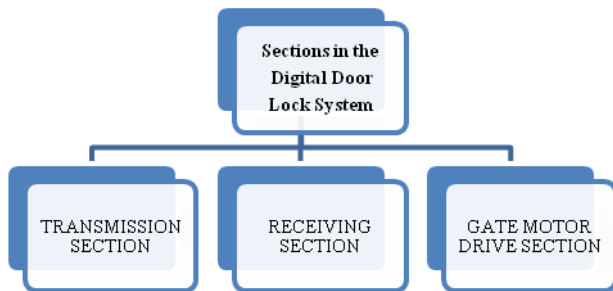

Figure 2.b. Flowchart

### 3. WORKING

The working of the project wireless access monitoring and controlling system for digital door lock is divided into three parts as –



### 3.1 Transmission Section

The figure 3.1 shows the Schematic Representation of Transmission Section. It mainly consists of AT89C2051 Microcontroller, AT2404, LM7805C and power supply. The microcontroller is used for programming purpose and also for storing information about users. Here we are using R315A RFID sensor as wireless transmitter which is used to verify the id of user and sends an acknowledgment to microcontroller to send password on user mobile. The R315A having frequency range up to 433 MHz

The microcontroller AT89C2051 is having 2k flash memory for processing and storing data. We are using 703 MHz crystal oscillator to provide clock signal to microcontroller for its operations. The transmitter section is mounted on main door. When user comes to open his locker then he has smart card which helps to identify his id. For verifying id of user we are using RFID sensor which is mounted on main door. Here we are using AT2404 as RFID sensor which having EEPROM memory to store id of user. The microcontroller is interfaced with AT2404 so that when id is verified controller will sent SMS of password on user mobile whose id is verified through GSM modem.

The voltage regulation IC LM7805C is used for voltage regulation purpose. It mainly converts +9V to regulated +5V for microcontroller and for AT2404. The various resistors and capacitors are used in circuit for biasing purpose. The LED mounted in circuit is used to indicate that transmitter is connected with receiver. We provide here Vcc as 9V by using battery of 9V.

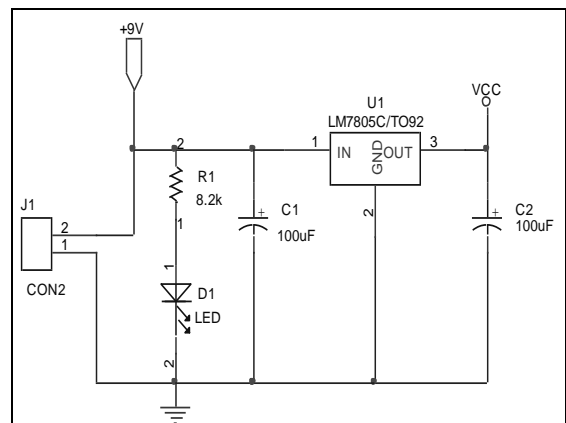

(a) Voltage Regulator Circuit

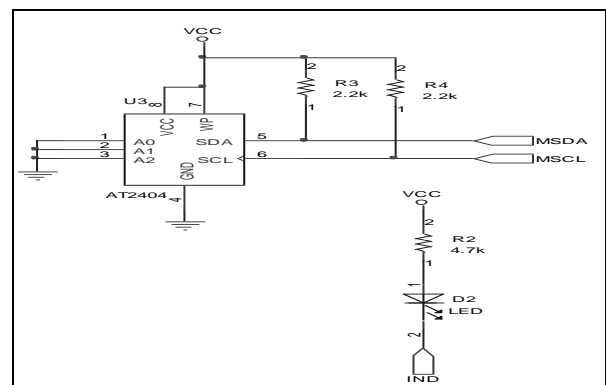

(b) AT89C2051 Microcontroller Circuit

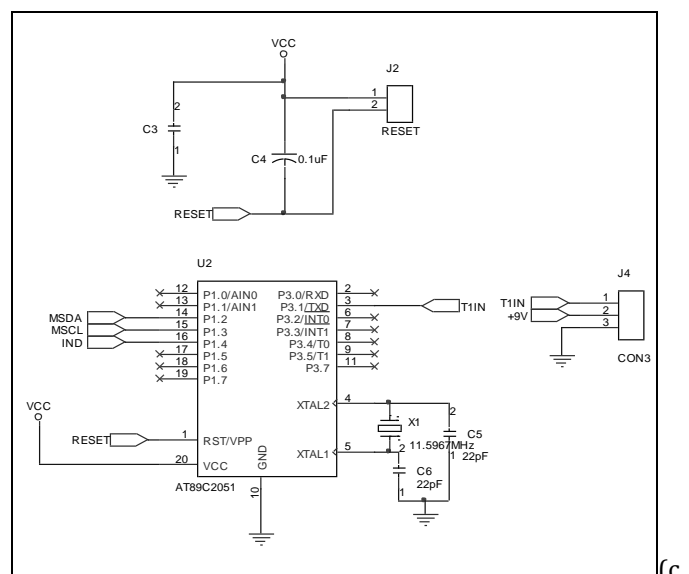

(c) Wireless RFID Sensor

Figure 3.1 Schematic Representation of Transmission Section

### 3.2 Receiving Section

The figure 3.2 shows the Schematic Representation of Receiving Section. It mainly consists of RF Receiver, MAX 232, LM7805C, and RS 232. This assembly is mounted on a locker subsystem. When the user enters into the room the password come on to his mobile which is stored in controller through GSM modem, then the main door get closed. For purpose of communication between transmitter and receiver, we are using wireless RF receiver.

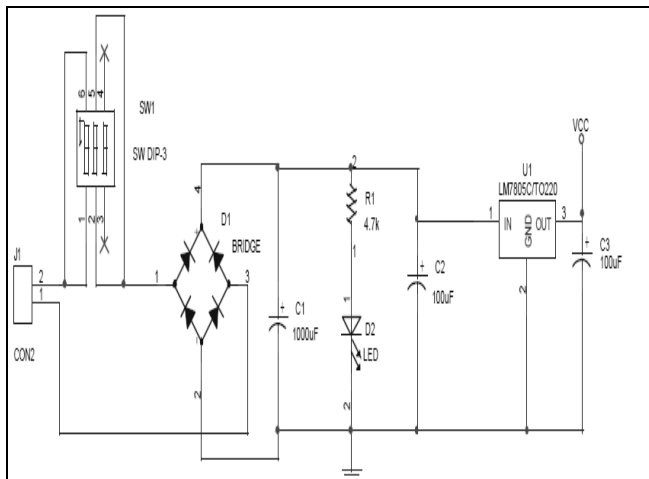

(a) Power supply circuit

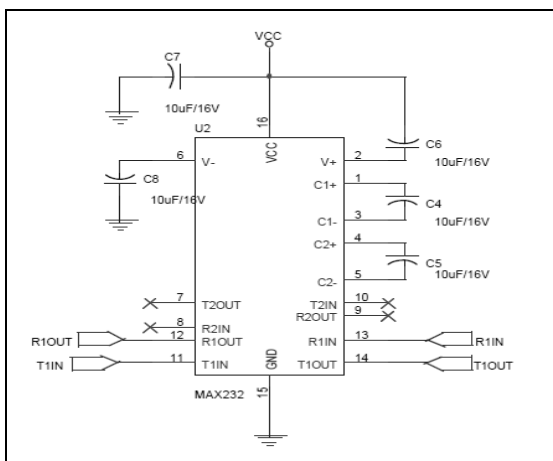

(b) MAX232 Circuit

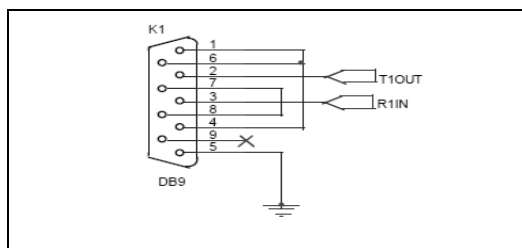

(c) RS232 connection

Figure 3.2 Schematic Representation of Receiving Section

We have use max232 to connect PC, In PC com port contain nine pins but we uses three of them TXD,RXD and GND, this com port operating voltage is +12 and -12, But operating voltages is 5v and 0v, or low So that it required voltage level converter that is max232. In serial communication baud rate must be set for precise data send and receiving.

The MAX232 is used for serial data transmission with RS232 which is one of the types of serial connector. The MAX232 is surrounded by five capacitors having a different value which provides us +5V as  $\pm 12V$  for serial data communication. The voltage regulator LM7805C is used for voltage regulation. Here we are using step down transformer which converts 230V to 9V and next to transformer there is rectifier circuit for providing constant DC supply and thus the voltage regulator provides +5V to MAX232 for its further operations.

We are mounting LCD display and keypad on the locker. So that when user get password on his mobile, then he can access it. He has two chances to enter the password and when he enter correct password then locker get open otherwise it remain closed. In second chance again user failed to enter the password then the main door gets locked and he gets trapped into that room.

### 3.3 Gate Motor Drive Section

The figure 3.3 shows the Schematic Representation of Gate Motor Drive Section. It mainly consists of TIP122, TIP127, BC547 and parallel connector. Here there are two gates motor circuits are required for main door and for the locker. Here we are using step down transformer which converts 230V to 12V. This 12 V is ac supply and we rectified it by using bridge rectifier to get pure DC of 12V. This 12V supply is required for our motor drive circuit.

The operation for these door opening and closing is totally depends upon the biased transistors as shown in figure 3.3. For the main door, when user provides his id to RFID sensor and if it is correct then door get open. During that condition, transistors Q1, Q4, Q5 and Q6 are conducting i.e. ON and other transistors are Q2, Q3, Q7 and Q8 are OFF. After entering into room, user get password and main door get closed. At that condition, some clock signal is provided to change state of motor. So that transistors Q2, Q3, Q7 and Q8 are ON and other transistors are Q1, Q4, Q5 and Q6 are OFF. Thus, this forwarding and reversing of sliding door is done with these biased transistors.

Similarly, the gate motor drive of locker get operated with help of transistors Q11, Q12, Q13, Q14, Q15, Q16, Q17 and Q18.

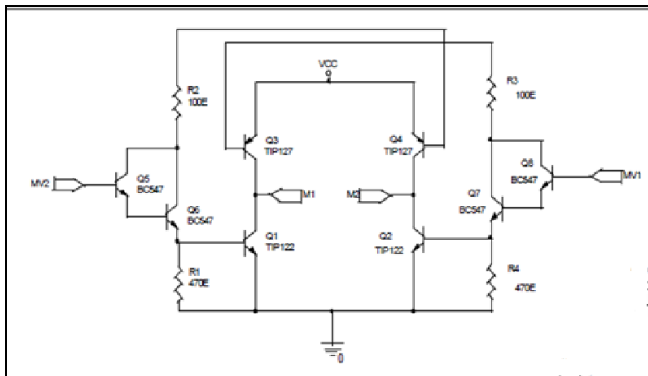

(a) Main Door circuit

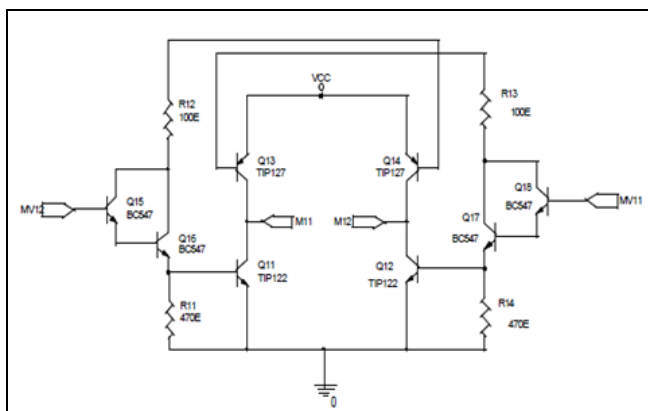

(b) Locker Circuit

Figure 3.3 Schematic Representation of Gate Motor Drive Section

## 4. IMPLEMENTATION

Nowadays the technologies become wider and more new features exist to make human life better. These help people to communicate with each other easier than before. People can communicate by many ways. Thus there is need of implementation of such technologies for various purposes. The implementation of project is done in two ways. These two ways are –

1. Software
2. Hardware

### 4.1 SOFTWARE

In software implementation, we are using VB6.0 software which is needed for our project implementation. Visual basic 6.0 begins to the forefront of modem programming language by provided and arrays to sophisticated set of simplify rapid application development. The visual part refers to the method used to create the graphical user interface. Rather than writing numerous lines of code describe the appearance and

location of interface element, you can simply drag and drop pre-built object into place on screen, if you have used a drawing program such as paint, you already have most of the skills necessary to create and effective user interface.

Forms used in Project of visual basic



Figure 4.1.a. Form 1 of VB for user identification



Figure 4.1.b. Form 2 of VB to enter password

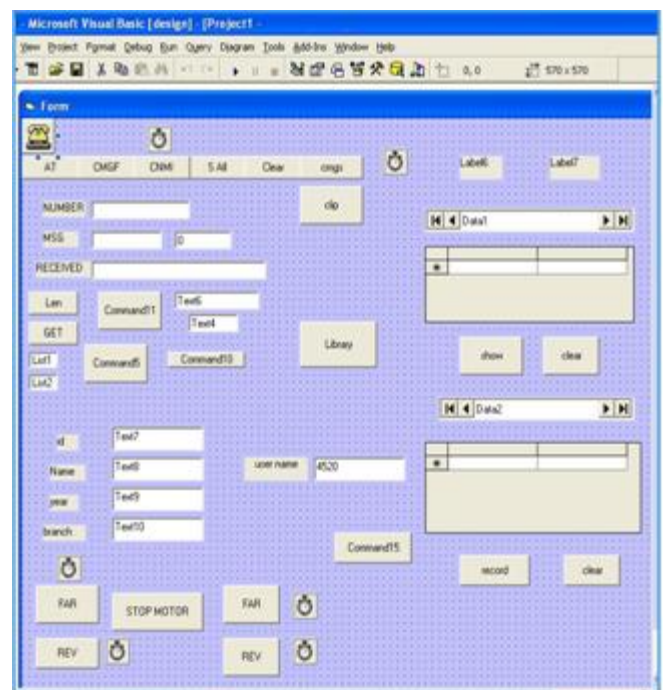

Figure 4.1.c. Form 3 of VB contains whole details of operations

## 4.2 HARDWARE

In hardware implementation, we are using various components such as AT89C2051, MAX232, LM7805C and some more. Each component used in hardware implementation is having its particular operation to perform. Below figure shows hardware implementation of transmitter, receiver, and gate motor driver.

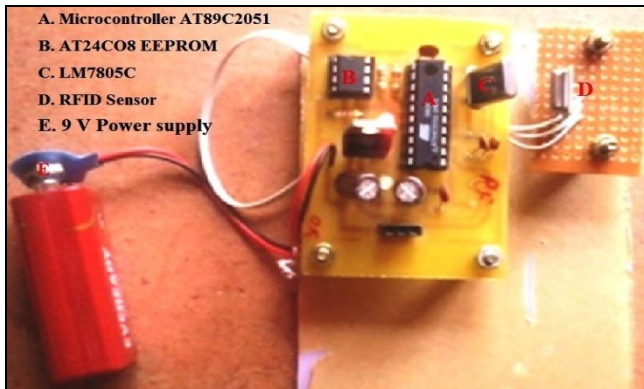

Figure 4.2.a Hardware implementation of Transmitter



Figure 4.2.b. Hardware implementation of Receiver

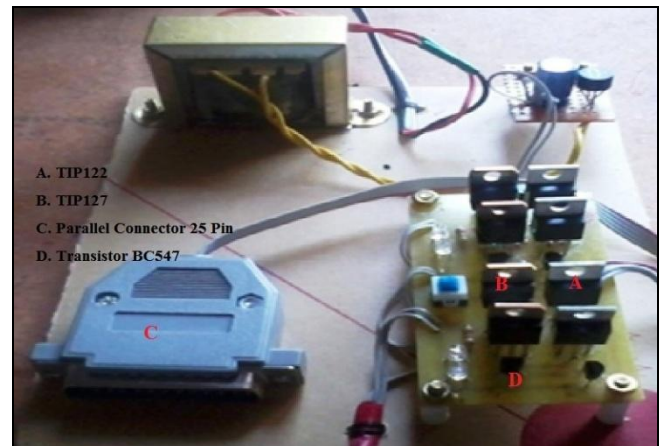

Figure 4.2.c Hardware implementation of gate motor drive

## 5. APPLICATIONS OF DIGITAL DOOR LOCK SYSTEM

Security system nowadays has become an important aspect to human life. As the need was demanding nowadays, this system was built in order to meet the demand in the security system. There are lots of applications of digital door lock systems. The following are the places where we can implement this digital door lock system- Homes, Offices, Banks, Hospitals, Various Industrial as well as Commercial Sectors, etc.

## 6. RESULT & CONCLUSION

This project led to a security door which can be accessed by entering the corresponding password will come on the mobile phone. The door opens automatically when the right code is entered and remains open for few seconds before closing back. If unauthorized person use this system, it calls main authority and prevent the intrusion. The designed system has been proven to be a reasonable advancement in access control and door security system technology. Digital door lock system is one of the most popular digital consumer device systems of user convenience and affordable price. It provides access only to authorized person. Thus, it is high secured automatic digital door lock system.

## REFERENCES

- [1] Il-kyu Hwang, Jin-wook Baek, " Wireless access monitoring and control system based on the digital door lock", Consumer Electronics, IEEE Transactions, Volume 53 , Issue 4 , Nov. 2007
- [2] R. Ramani S. Selvaraju, S.Valarmathy, P.Niranjan," Bank Locker Security System based on RFID and GSM

- Technology*", International Journal of Computer Applications (0975 - 8887) Volume 57- No.18, November 2012, pp.15-20
- [3] Nwankwo Prince. N, Nsionu Ifeanyi. I., Ezeilo Chiegboka Joseph, "*Design and Implementation of Microcontroller Based Security Door System (Using Mobile Phone & Computer Set)*", Journal of Automation and Control Engineering, Vol. 1, No. 1, January 2013, pp.65-69
- [4] O. Ameze and A. Ejoke, "*Security Lock System Using Passcode and Smartcard,*" Electrical/Electronic Department, University of Port Harcourt, Nigeria, 2007, ch. 2, pp. 35.
- [5] Gilbert Thio, Tham Kok Foong, Rajparthiban Kumar, L.K. Moey, "*Design of RFID Proximity Security Door Lock*", JASA 3, July 2007
- [6] Kawser Wazed Nafi, Tonny Shekha Kar, Sayed Anisul Hoque "*An Advanced Door Lock Security System using Palmtop Recognition System*", International Journal of Computer Applications (0975 - 8887) Volume 56- No.17, October 2012
- [7] Gyanendra K Verma, Pawan Tripathi, "*A Digital Security System with Door Lock System Using RFID Technology*", International Journal of Computer Applications (0975 - 8887) Volume 5- No.11, August 2010

## BIOGRAPHIES



**Vaibhav V. Deshmukh** pursuing M.Tech. Degree from RTM Nagpur University, India and also received the B.E. Degree from SGB Amravati University, India and His research interests focus on VLSI, Embedded System and MEMS.



**Amit V. Raut** pursuing M.Tech. Degree from RTM Nagpur University, India and also received the B.E. Degree from SGB Amravati University, India and His research interests focus on Core electronics like VLSI, VHDL.