

Ultrasonic Sensor with Accelerometer Based Smart Wheel Chair Using Microcontroller

Sandeep Kumar, P.Raja

¹ Ph.D Student, Electronics & Communication, OPJS University, Churu, Rajasthan, India

² Assistant Professor, Electronics & Communication, BRCM College Bahal, Bhiwani, India

Abstract - The objective of paper is to design a low cost prototype of a self driven, power assisted smart wheelchair for the disabled belonging to poor community. The wheelchair is equipped with all the necessary electronics to ensure safety and ease of operation. The wheelchair will be made user friendly to reduce the load of caretaker and will boost the confidence level of the disabled person by making him/her self-dependent. Wheelchairs are designed for handicapped people. Children, young or old people can use it. When a person is unable to walk or even when a person is disabled, deformed or paralysed from the legs, a chair with four wheels is generally used for their movement. The system is divided into two main units: Mems Sensors and wheelchair control. The Mems sensor, which is connected to hand on wheel chair, is an 3-axis accelerometer and ultrasonic sensors converts into digital values and gives it to the 8051 controller.

Key Words: Accelerometer, Analog Joystick, ADC, Ultrasonic Sensor, Microcontroller, LCD, GSM Modem, Mobile

1. INTRODUCTION

In India, there has always been a tremendous need for an affordable and well designed electric power wheelchair to provide to the needy. Aged people and disabled people who have difficulty in walking are increasing. The significance of “electric powered wheelchair” and “electric power-assisted wheelchair” which assist driving force using electric motors on both wheels and spreads their areas of life has been recently enhanced. A normal powered wheelchair may cost between Rs.60,000 to Rs.10,50,000, the new low-cost electric wheelchair is said to reduce the price by half. The objective is not only to develop a low-cost electric wheelchair, but to develop one

technically best suited for Indian environment, whether urban or rural.

The wheelchair is one of the most commonly used assistive devices for enhancing the personal mobility of people with disabilities. An estimated 1% of the world's population, or just over 65 million people, need a wheelchair according to the World Health Organization (WHO). In most developing countries, few of those who need wheelchairs have access, production facilities are insufficient and wheelchairs are often donated without the necessary related services. Providing wheelchairs that are appropriate, well-designed and fitted not only enhances mobility, but also opens up a world of education, work and social life for those in need of such support. Our approach allows the users to use human gestures of movement like hands and synchronize them with the movement of the wheelchair so that they can use it with comfort.

2. BLOCK DIAGRAM

The system comprises of different main parts:

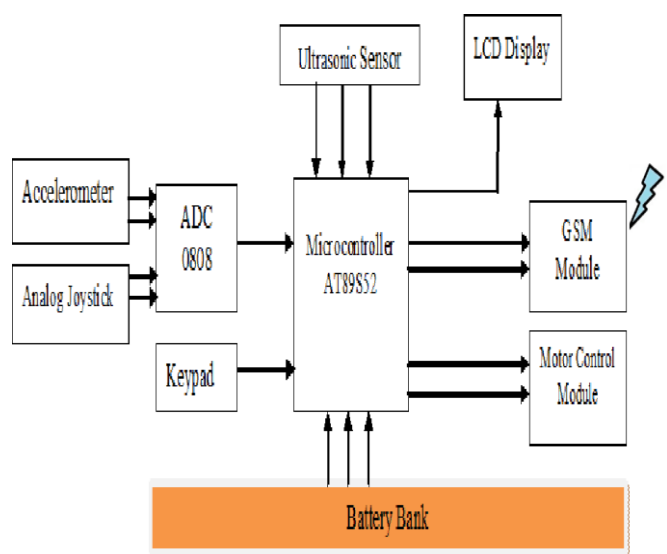

Fig -1: Block Diagram of Ultrasonic sensor with Accelerometer Smart Wheel Chair

Accelerometer, Analog joystick, ADC, keypad, Ultrasonic Sensor, GSM Module and Motor control module. In Accelerometer and Ultrasonic sensor gives input to the ADC and ADC convert analog input into digital output is transmitted to the controller and then transmitted by GSM Module to Mobile receiver. DC Motors which are interfaced to the controller by the motor driver controls the direction of the wheelchair according to the signal received by ultrasonic sensor.

3. General Discription

3.1 Ultrasonic Sensor

Ultrasonic Sensors are devices that use electrical-mechanical energy transformation to measure distance from the sensor to the target object. Ultrasonic waves are longitudinal mechanical waves which travel as a sequence of compressions and rarefactions along the direction of wave propagation through the medium. Apart from distance measurement, they are also used in ultrasonic material testing (to detect cracks, air bubbles, and other flaws in the products), Object detection, position detection, ultrasonic mouse, etc.

These sensors are categorized in two types according to their working phenomenon – piezoelectric sensors and electrostatic sensors. Here we are discussing the **ultrasonic sensor using the piezoelectric principle. Piezoelectric ultrasonic sensors** use a piezoelectric material to generate the ultrasonic waves. **An ultrasonic sensor** consists of a transmitter and receiver which are available as separate units or embedded together as single unit. The below image shows the ultrasonic transmitter and receiver.



Fig – 2: Ultrasonic sensor with Wheel Chair

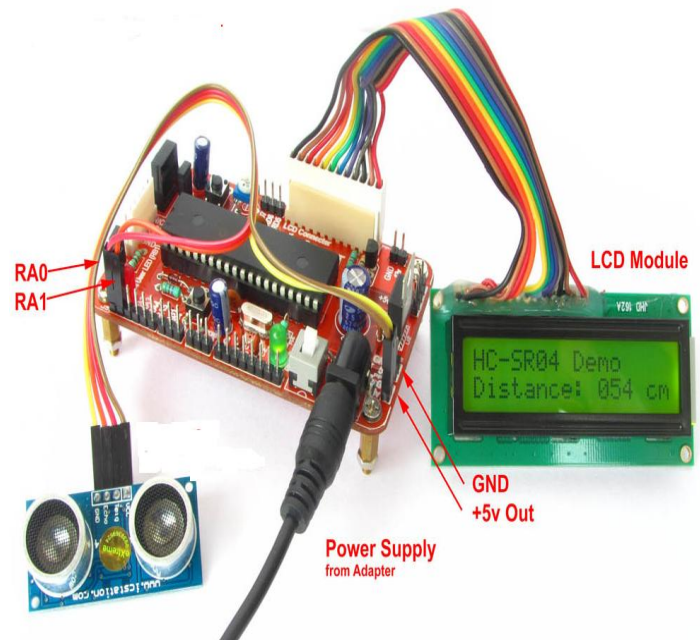

Fig -3: Circuit Diagram of Ultrasonic sensor with Microcontroller

3.2 Acelerometer

The ADXL335 is a complete 3-axis acceleration measurement system. An accelerometer is a sensor that measures the physical acceleration experienced by an object due to inertial forces or due to mechanical excitation. It contains a polysilicon surface-micro machined sensor and signal conditioning circuitry to implement open-loop acceleration measurement architecture. The output signals are analog voltages that are proportional to acceleration. The accelerometer can measure the static acceleration of gravity in tilt-sensing applications as well as dynamic acceleration resulting from motion, shock, or vibration. The sensor is a polysilicon surface micro machined structure built on top of a silicon wafer. Polysilicon springs suspend the structure over the surface of the wafer and provide a resistance against acceleration forces. Deflection of the structure is measured using a differential capacitor that consists of independent fixed plates and plates attached to the moving mass. The fixed plates are driven by 180° out-of-phase square waves. Acceleration deflects the moving mass and unbalances the differential capacitor resulting in a sensor output whose amplitude is proportional to acceleration. Phase-sensitive demodulation techniques are then used to determine the magnitude and direction of the acceleration.

The ADXL335 uses a single structure for sensing the X, Y, and Z axes. As a result, the three axes' sense directions are

highly orthogonal and have little cross-axis sensitivity. Mechanical misalignment of the sensor die to the package is the chief source of cross-axis sensitivity. Mechanical misalignment can, of course, be calibrated out at the system level.

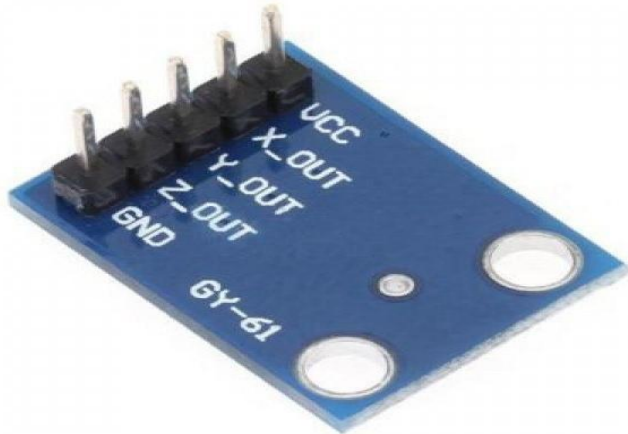

Fig - 4: ADXL335 Accelerometer



Fig -5: Circuit Diagram of Accelerometer sensor with Microcontroller

4. Working

The proposed model is a wheelchair prototype built around eight bit microcontroller platforms. The microcontroller takes the input from various sensors installed on the wheelchair covering all the directions and provides corresponding outputs that helps user to take decision and make judgments for the safe movement and control of the wheelchair. For movement control an analog joystick is to be installed on the wheelchair left arm-rest that will be responsible for the forward, backward and left-right movements of wheelchair. The output of joystick is analog in nature; therefore the signal will be converted to digital form using an analog-to-digital converter before being fed as an input to the microcontroller for further processing. The microcontroller will continuously poll for

the inputs from the joystick and corresponding outputs will help controlling the wheelchair motors for movement control. A 20x4 line LCD module is interfaced through microcontroller to display necessary information for the

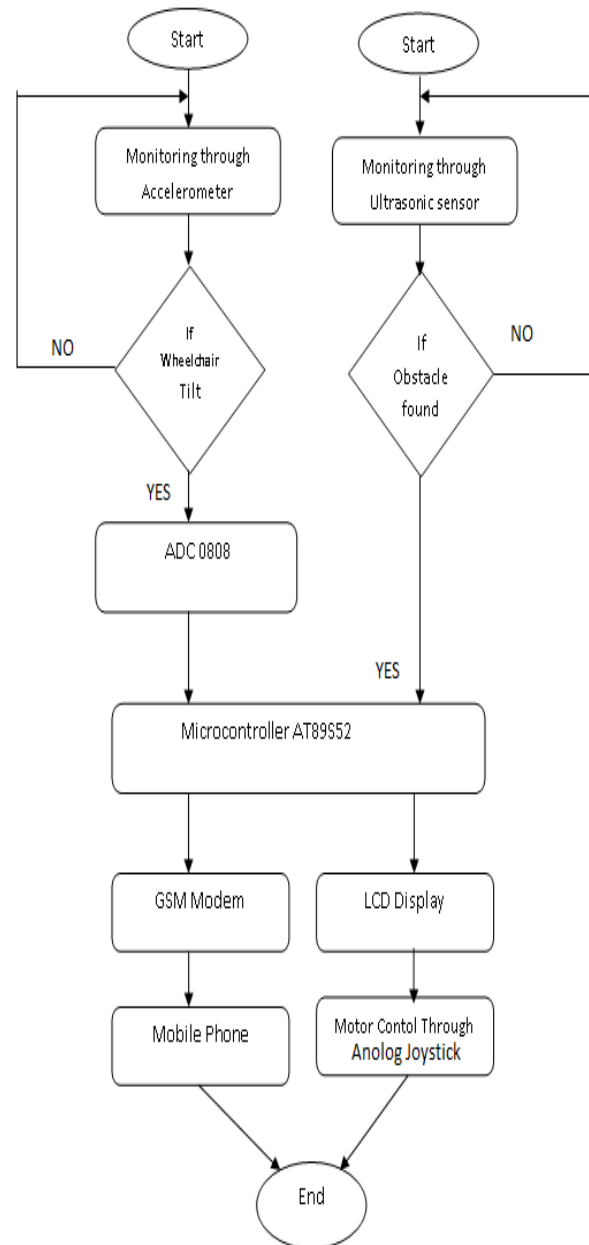

Fig -6: Flow Chart of Project

user. The wheelchair will also be equipped with proper speed controls through an accelerator. The wheelchair will be having low power microcontroller based LED headlights, taillights for proper night vision as well as left & right indicator bulbs for safe drive. The wheelchair is outfitted with a highly responsive real-time accident

information system. The system will send alert signal to the concerned persons through SMS/call in case of an accident. The system will accept analog input from a 3-axis accelerometer; ADC will convert it into digital signal; microcontroller will process this digital signal to make decisions and finally the output values will be used to send alert through GSM modem accordingly. The Ultrasonic sensor will send signal to the microcontroller and according to that signal microcontroller can turn the wheel chair left or right with the help of DC Motor.

5. CONCLUSIONS

This paper proposed a work of fiction safety driving control scheme for electric power assisted smart wheelchairs based on the keypad interfacing with microcontroller. We have designed an electric power monitoring and management system based upon wireless sensor network. This system employed the AT89S52 as MCU to satisfy real-time, compatible and reliable monitoring requirements. Some driving experiments on the practical plain road verified the effectiveness of the proposed control system. The bulky and complex designs have, however, been overcome by exploring new smart wheelchair. Interfacing these special sensors to the wheelchair was controlled by the AT89S52. In addition, the sensors types can be improved to play a secondary role in sharing the control of the smart wheelchair. Most importantly, the developed system can measure multiple electric parameters automatically such as Tilting, Obstacle and battery power backup which are desired by the electrical administration. More software work for this module is in development stage such as speech synthesis and speaker identification. These works should improve the application in the next future.

REFERENCES

- [1] Daisuke Chugo, Kenji Shiotani, Yuki Sakaida, Sho Yokota, Hiroshi Hashimoto "An Automatic Depressurization Assistance based on an Unconscious Body Motion of a Seated Patient on a Wheelchair " RIKEN-TRI Collaboration Center for Human-Interactive Robot Research (RTC) RIKEN (The Institute of Physical and Chemical Research) Nagoya, Aichi, Japan.
- [2] Chowdhury, Zamshed Iqbal, et al. "Design and implementation of Pyroelectric Infrared sensor based security system using microcontroller." *Students' Technology Symposium (TechSym), 2011 IEEE*. IEEE, 2011.
- [3] Fezari, Mohamed, Mounir Bousbia-salah, and Mouldi Bedda. "Voice and Sensor for More Security on an Electric Wheelchair." *Information and Communication Technologies, 2006. ICTTA'06. 2nd. Vol. 1. IEEE, 2006.*
- [4] Takahashi, Kazuki, Hirokazu Seki, and Susumu Tadakuma. "Safety driving control for electric power assisted wheelchair based on regenerative brake." *Industrial Technology, 2006. ICIT 2006. IEEE International Conference on*. IEEE, 2006.
- [5] Megalingam, Rajesh Kannan, et al. "Power Aware Automatic Microcontroller Based Smart, College Electric Bell System with Time Display." *MEMS, NANO, and Smart Systems (ICMENS), 2009 Fifth International Conference on*. IEEE, 2009.
- [6] Fezari, Mohamed, and Abd-Erahman Khati. "New speech processor and ultrasonic sensors based embedded system to improve the control of a motorised wheelchair." *Design and Test Workshop, 2008. IDT 2008. 3rd International*. IEEE, 2008.
- [7] Oskoei, Mohammadreza Asghari, and Huosheng Hu. "Myoelectric based virtual joystick applied to electric powered wheelchair." *Intelligent Robots and Systems, 2008. IROS 2008. IEEE/RSJ International Conference on*. IEEE, 2008.
- [8] Fezari, Mohamed, Abderrahmene Khati, and Hamza Attoui. "Embedded system based on multiprocessors to improve the control of a motorised wheelchair." *Design & Technology of Integrated Systems in Nanoscal Era, 2009. DTIS'09. 4th International Conference on*. IEEE, 2009.
- [9] Fezari, Mohamed, and Mounir Bousbia-Salah. "Speech and sensor in guiding an electric wheelchair." *Automatic Control and Computer Sciences* 41.1 (2007): 39-43.
- [10] Seki, Hirokazu, and Yoshiaki Takahashi. "Downward slope driving control for electric powered wheelchair based on capacitor regenerative brake." *Industrial Electronics, 2009. IECON'09. 35th Annual Conference of IEEE*. IEEE, 2009.
- [11] Tanohata, Naoki, Hiroki Murakami, and Hirokazu Seki. "Battery friendly driving control of electric power-assisted wheelchair based on fuzzy algorithm." *SICE Annual Conference 2010, Proceedings of*. IEEE, 2010.
- [12] Dilok Puanhvuang, y odchanan W ongsawat "Semi-Automatic P300-Based Brain-Controlled Wheelchair " *Proceedings of 2012 1CME*

- International Conference on Complex Medical Engineering July I - 4, Kobe, Japan. [22] www.DEL-CORAZON.org
- [13] Augie Widyotriatmo, Saqi Khudi Rauzanfiqr, Suprijanto **"A Modified PID Algorithm for Dynamic Control of an Automatic Wheelchair"** 2012 IEEE Conference on Control, Systems and Industrial Informatics (ICCSII) Bandung, Indonesia, September 23-26,2012.
- [14] Chun-Rong Huang, Member, IEEE, Pau-Choo (Julia) Chung, Fellow, IEEE, Kuo-Wei Lin, and Sheng-Chieh Tseng **"Wheelchair Detection Using Cascaded Decision Tree"** IEEE TRANSACTIONS ON INFORMATION TECHNOLOGY IN BIOMEDICINE, VOL. 14, NO. 2, MARCH 2010.
- [15] Octavian Postolache, Joaquim Mendes **"Unobstrusive Heart Rate and Respiratory Rate Monitor Embedded on a Wheelchair"** MeMeA 2009 - International Workshop on Medical Measurements and Applications Cetraro, Italy May 29-30, 2009.
- [16] Anthony Remazeilles, Christophe Leroux, G'érard Chalubert, Laurent Delahoche, Bruno Marhic, Isabelle Laffont and Nicolas Biard **"Automatic Grasping Task with a Catadioptric Sensor for Disabled People"** 2008 10th Intl. Conf. on Control, Automation, Robotics and Vision Hanoi, Vietnam, 17-20 December 2008.
- [17] Mohamed Fezari, Abd-Erahman Khati **"New speech processor and Ultrasonic Sensors Based Embedded system to Improve the Control of a Motorised Wheelchair"** Laboratory of Automatic and Signals Annaba University of Annaba, Faculty of Engineering,Algeria.
- [18] Chandan Banerjee, Harish Gupta, Kumar Sushobhan **"Low Cost Speech and Vision Based Wheel Chair For Physically Challenged"** Electronics & Communication Engineering, Vellore Institute of Technology University, Vellore, India.
- [19] Kailas, A., **"Basic human motion tracking using a pair of gyro + accelerometer MEMS devices,"** in *e-Health Networking, Applications and Services (Healthcom), 2012 IEEE 14th International Conference on*, vol., no., pp.298-302, 10-13 Oct. 2012.
- [20] Rahulanker, R.; Ramanarayanan, V., **"Battery assisted wheel chair,"** in *Power Electronics, 2006. IICPE 2006. India International Conference on*, vol., no., pp.167-171, 19-21 Dec. 2006 doi: 10.1109/IICPE.2006.468536
- [21] Datasheet of ADXL335