

CLOSED LOOP CONTROL OF HIGH STEP-UP DC/DC CONVERTER BASED ON COUPLED INDUCTOR AND SWITCHED-CAPACITOR

Josie Baby¹, Della David²

¹PG Scholar ,Dept .of Electrical and Electronics, Jyothi Engineering College, Cheruthuruthy, Thrissur, Kerala,

²Assistant professor, Dept. of Electrical and Electronics, Jyothi Engineering College, Cheruthuruthy, Thrissur, Kerala

Abstract - This paper proposes a high voltage gain dc/dc converter with coupled inductor cells and switched capacitor for renewable energy applications. It includes coupled inductor, switched capacitor and voltage multiplier cell. Switched capacitor charged during off period by using the energy stored in the coupled inductor. This will increase the performance of the converter. The operation principle and steady state analyses are discussed thoroughly. Simulation is done with 40V input voltage, 300W output power and 400V output voltage using MATLAB.

Keywords—Dc/dc converter, boost converter, coupled inductor, PWM control scheme

1. INTRODUCTION

The future is looking towards alternative power sources all of which will need to be regulated in one Form or another. To make this possible, a highly efficient low cost product will have to be designed. Among all the different converter designs only a few are capable of providing high power with high efficiency. The basic switched-mode dc-dc converters including buck, boost, buck-boost, cuk, zeta, and sepic have been used in various electronic applications due to their numerous advantages such as good performance, simple structure, , high efficiency, easy design, and simple control circuit. To get high voltage from low voltage boost converters are used. The high voltage converters are widely used in many industry applications, such as photovoltaic systems, fuel cell systems, electric vehicles, and high intensity discharge lamps. PV cells can be connected in series in order to obtain a large dc voltage. Though PV cells can be made into array and connected in series to produce high voltage there exist serious problems like shadowing effects, short circuit which drastically reduces its efficiency. In order to overcome such adverse effects this micro source energy is utilized by the high step up converter to produce high voltage and satisfy the demands. Thus high step up dc-dc converters are used as front end converters to step from low voltage to high

voltage which are required to have a large conversion ratio, high efficiency and small volume [2].

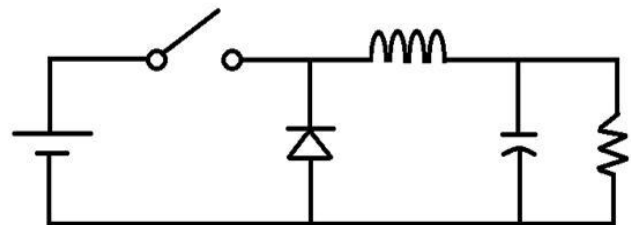

Fig.1.conventional boost converter

The conventional boost converters are not suitable for the high step-up conversion [3] applications because the duty cycle of the boost converter with high step-up conversion is large, which results in narrow turn off time. The extremely narrow turn-off time will bring large peak current and considerable conduction and switching losses [4] .conventional boost converter is shown in fig(1). However extreme duty ratio will result in serious reverse recovery problems and electromagnetic interferences. Impacts of SiC (silicon carbide) MOSFETS on converter, switching and conduction losses are reduced even though fast switching is done. Si diodes have ideal, but sill SiC devices processes large amount of ringing current at turn off relatively to other devices. And the SiC are comparing0 with Si [5].

Forward converter, push-pull converter and flyback converters are transformer based converters (isolated converters) ,can achieve high voltage gain by adjusting the turns ratio of the transformers. But it has the disadvantages of voltage spike across the main switch and power dissipation due to leakage inductance of the transformer [7] and safety standard needs [8]. In [9] it proposes a novel single switch high step-up converter. The coupled inductor is act as both forward and flyback converter, thus it can charge two capacitors in parallel and discharge in series.

A high gain transformer less converter is presented in [10]. It consisting of a hybrid combination of two two-level dc/dc converters . Thus it have large no of components and it will increase cost. Switched capacitor techniques have been used widely inorder to improve high voltage gain [11-12]. But here high charging current will flowing through main switch and increase the conduction losses.

Converters with charge pump will provide voltage gain in proportion to the stage number of capacitors, but its drawback includes fixed voltage gain and large device area. In [15] diode capacitor techniques are implemented. It can achieve high voltage gin in proportional to the number of stages, which is able to be extended by adding capacitors and diodes. But it may result in the larger voltage drop consumption due to cut in voltage of the diodes in series.

Tapped inductor technology is explained in [13]. Different converter topologies are explained. Coupled inductor based converters also achieve high step-up voltage gain by adjusting the turns ratio [14]. However the stored energy in the leakage inductor causes a voltage spike on the main switch and deteriorates the conversion efficiency. To overcome this problem, coupled inductor based converter with active clamping circuits are presented [16].It compare proposed converter and conventional boost converter with coupled inductor only and active clamp circuit only. High step-up converter with two switch [17-19] and one switch [20] are explained. As no of switches increased losses will increased. However the conversion ratio is not large enough.

In order to achieve high voltage gain, this paper proposes a high step-up voltage gain dc/dc converter with coupled inductor and switched capacitor techniques. Here Pulse Width Modulation techniques are introduced to get better voltage regulation.

2. CIRCUIT CONFIGURATION

The circuit consisting of a coupled inductor and two voltage doubler circuit . It is shown in fig.2. The switched capacitor will charged during the switch- off period using the energy stored in the coupled inductor, which increases the voltage transfer gain. The switching stress across the switch is reduced. Using the passive clamping circuit the energy stored in the leakage inductor is recycled . The simulations are done in MATLAB for 40V input voltage and 300W power range.

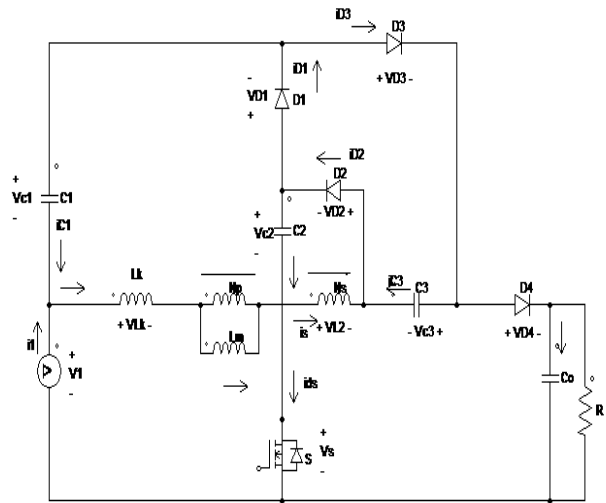

Fig 2. Circuit diagram of the presented high step-up converter

2.1 Operation of the converter

The switch is turned ON, the supply voltage magnetises the leakage inductance and mutual inductance. Thus the current through the leakage inductance and mutual inductance of the coupled inductor increases linearly and at the secondary side the current decreases. During this time interval diodes $D_1, D_2,$ and D_4 are conducting and diode D_3 conducting for a small time period. The capacitor C_3 is charged by dc source $V_1,$ clamp capacitor and the secondary side of the coupled inductor. The clamp capacitor C_1 is charged by the stored energy in capacitor C_2 and the energies of leakage inductor L_k and magnetising inductance $L_m.$ This interval ends when i_{Lk} is equal to $i_{Lm}.$ When the switch is turned OFF, the clamp capacitor C_1 is charged by the capacitor C_2 and the energies of leakage inductance L_k and magnetising inductance $L_m.$ The current through the leakage inductance and magnetising inductance are decreasing. Also, a part of the energy stored in L_m is transferred to the secondary side of the coupled inductor and which charges the capacitor C_2 through diode $D_2.$ In this interval the dc input voltage V_1 and stored energy in the capacitor C_3 and inductance of both sides of the coupled inductor charge the output capacitor C_0 and provides the demand energy of the load $R_L.$

3. CONTROL STRATEGY

In order to achieve good voltage regulation closed loop control methods are introduced. In pulse width modulation (PWM) control, the duty ratio is linearly modulated in a direction that reduces the error. When the input voltage is perturbed, that must be sensed as an output voltage change and error produced in the output voltage is used to change the duty ratio to keep the output voltage to the reference value. The control circuit is shown in Fig.3

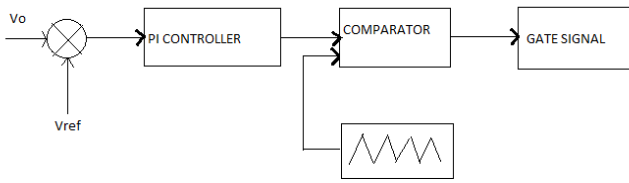

Fig.3. PWM control

4. SIMULATION RESULTS

The simulation of the high step-up dc/dc converter with coupled inductor and switched capacitor techniques has been carried out. An input voltage of 40V and switching frequency of 60 kHz is chosen and an output of 400V is obtained. Specifications of the implemented prototype are shown in table 1 .

TABLE 1.SPECIFICATIONS

PARAMETER	VALUE
Input dc voltage	40 V
Output voltage	400 V
Switching frequency	60 kHz
Coupled inductor	$L_k = 1 \mu\text{H}$, $L_m = 300 \mu\text{H}$
Capacitors C_1, C_2, C_3, C_0	47,47,100,220 μF

Fig.4.Simulink model of the presented step-up converter

The Simulink model of the converter is shown in fig 4 . It consisting of dc input voltage(V1) ,coupled inductor, active power switch (S), four diodes and capacitors. Capacitor C1 and diode D1 are employed as clamp circuit respectively. The capacitor C3 is employed as the capacitor of the voltage multiplier cell. The capacitor C2 and diode D2 are the circuit elements of the voltage multiplier which increase the voltage of the clamping capacitor C1.

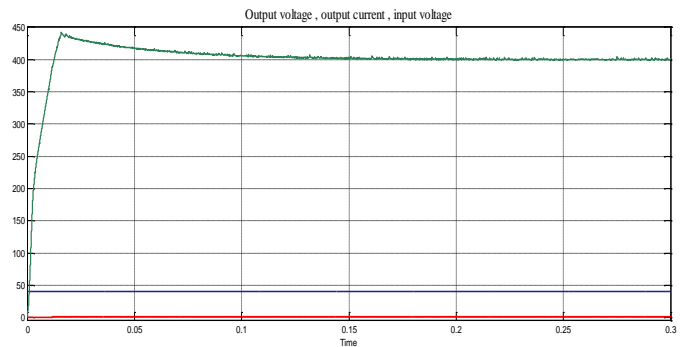
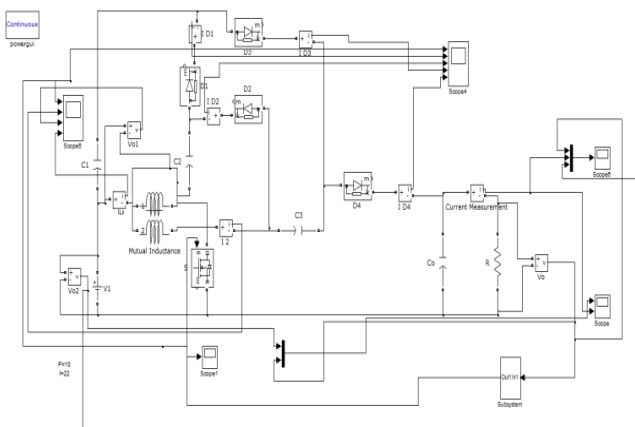

Fig.5.waveform of output voltage ,input voltage and output current

Fig.5 shows the waveform of the output voltage, input voltage and output current under 300W. Fig.6 shows the waveform of gate pulse having a width of 0.5 and current across the diodes D1,D2,D3 and D4. In fig.7 the current across the leakage inductor (I_{Lk}),voltage across the mutual inductor (V_{Lm}) and the current at the secondary side of the coupled inductor (I_s) are shown.



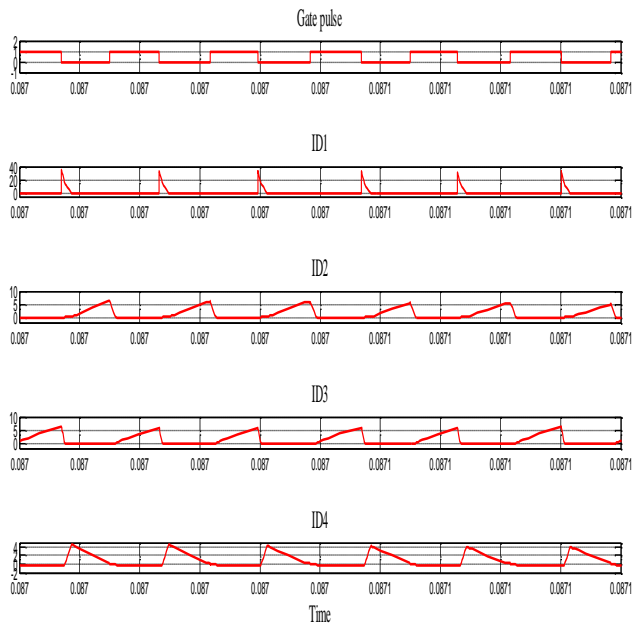

Fig.6.waveforms of gate pulse, current through diodes

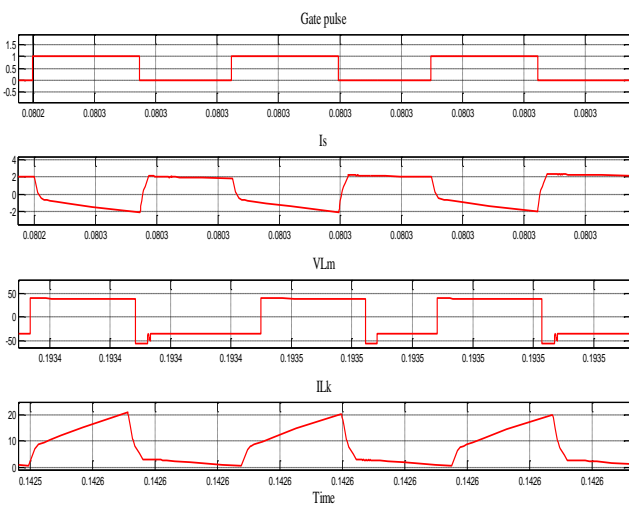

Fig.7.Waveforms gate pulse, current secondary and leakage inductance and magnetising inductance voltage

The load regulation can be seen in Fig.8. The line regulation at $V_{in} = 44\text{ V}$ and $V_{in} = 36\text{ V}$ are given if Fig.9(a) and 9(b). Fig.10 shows the waveform of voltage across the switch. Which is about 80V.

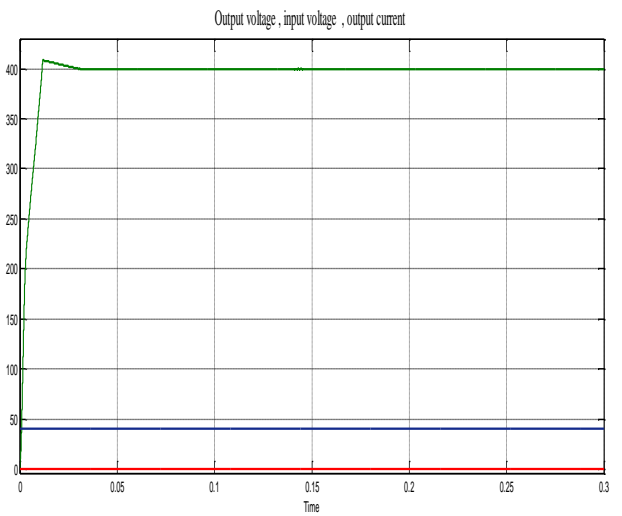

Fig.8 Load regulation

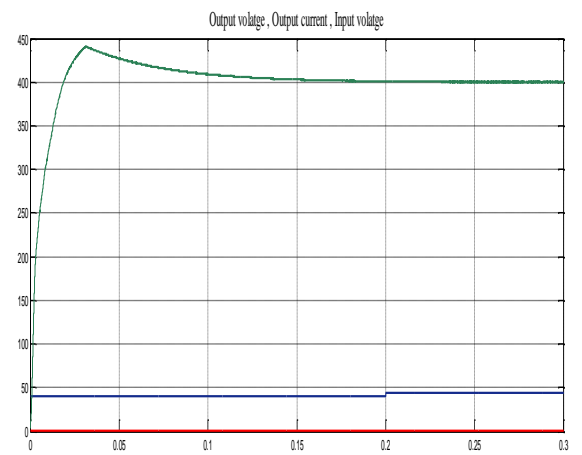

Fig.9(a) Line regulation at 44V

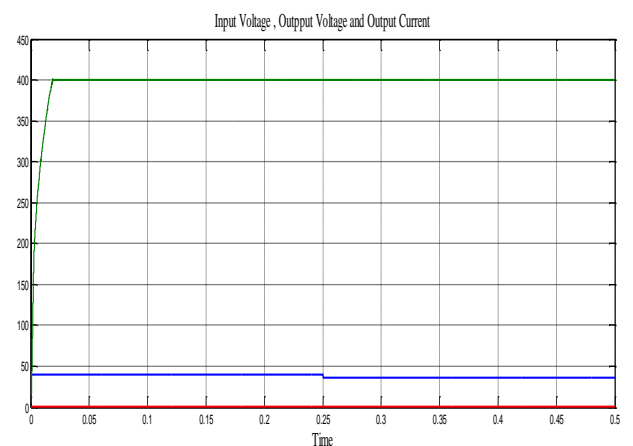

Fig.9 (a) Line regulation at 36V

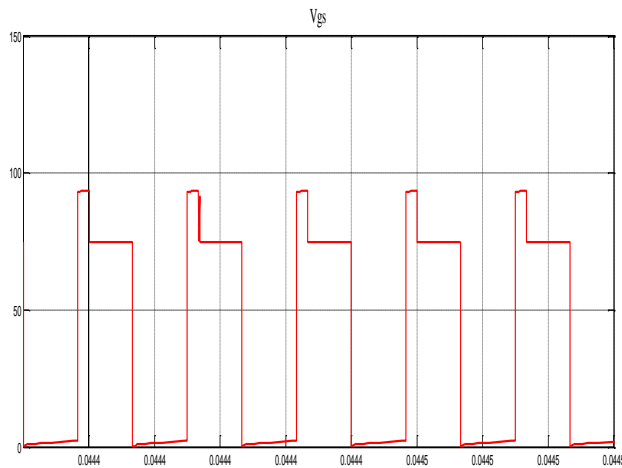

Fig.10 Voltage across the switch

5. CONCLUSION

A high step-up dc/dc converter based on integrating coupled inductor and switched-capacitor are proposed for renewable energy applications. The energy stored in the leakage inductance of the coupled inductor is recycled by using switched capacitors. The voltage stress across the main switch is reduced. Here the gate signals are generated using PWM control schemes. In order to lien and load regulation .The simulation of the converter with 40V input voltage, 300W power and 400V/.75A has been carried out using MATLAB software.

REFERENCES

[1] Ali Ajami, Hossein Ardi, and Amir Farakhor” A Novel High Step-up DC/DC Converter Based on Integrating Coupled Inductor and Switched-Capacitor Techniques for Renewable Energy Applications”, IEEE TRANSACTIONS ON POWER ELECTRONICS, VOL. 30, NO. 8, AUGUST 2015.

[2] R. J. Wai and K. H. Jheng, “High-efficiency single-input multiple-output DC–DC converter,” *IEEE Trans. Power Electron.*, vol. 28, no. 2, pp. 886– 898, Feb. 2013.

[3] “Power Electronics” – Daniel W. Hart, Published by McGraw-Hil.

[4] L.S.Yang,T.J.Liang,andJ.F.Chen,“Transformer-lessDC–DCconverter with high voltage gain,” *IEEE Trans. Ind. Electron.*, vol. 56, no. 8, pp. 3144–3152, Aug. 2009.

[5] J. A. Carr, D. Hotz, J. C. Balda, H. A. Mantooth, A. Ong, and A. Agarwal, “Assessing the impact of SiC MOSFETs on converter interfaces for distributed energy

resources,” *IEEE Trans. Power Electron.*, vol. 24, no. 1, pp. 260–270, Jan. 2009.

[6] Zhao, Q.,Lee, F.C.:”Highefficiency ,high step-updc-dc converter” *IEEE Trans. Power Electron.*,2013,18,(1),pp. 65-73.

[7] Wai, R.J., Lin, C.Y., Duan, RY., Chang, Y.R:”High efficiency power conversion system for kilowatt-level stand-alone geneartiom unit with low innput voltage”, *IEEE Trans. Power Electron.*,2008, 55, (10), pp.3702-3714.

[8] T. J. Liang, J. H. Lee, S. M. Chen, J. F. Chen, and L. S. Yang, “Novel isolated high-step-up DC–DC converter with voltage lift,” *IEEE Trans. Ind. Electron.*, vol. 60, no. 4, pp. 1483–1491, Apr. 2013.

[9] Y. P. Hsieh, J. F. Chen, T. J. Liang, and L. S. Yang, “Analysis and implementation of a novel single-switch high step-up DC–DC converter,” *IET Power Electron.*, vol. 5, no. 1, pp. 11–21, Jan. 2012.

[10] L.S.Yang,T.J.Liang,andJ.F.Chen,“Transformer-lessDC–DCconverter with high voltage gain,” *IEEE Trans. Ind. Electron.*, vol. 56, no. 8, pp. 3144–3152, Aug. 2009.

[11] C. L. Wei and M. H. Shih, “Design of a switched-capacitor DC-DC converter with a wide input voltage range,” *IEEE Trans. Circuits Syst.*, vol. 60, no. 6, pp. 1648–1656, Jun. 2013.

[12] W. Qian, D. Cao, J. G. C. Rivera, M. Gebben, D. Wey, and F. Z. Peng, “A switched-capacitor DC–DC converter with high voltage gain and reduced component rating and count,” *IEEE Trans. Ind. Electron.*, vol. 48, no. 4, pp. 1397–1406, Jul. 2012.

[13] V.RTintu,g.Mary,,”Tapped inductor technology based on dc-dc converter”,*IEEE ICSCCN 2011*,pp. 747-753.

[14] W. Li, W. Li, X. Xiang, Y. Hu, and X. He, “High step-up interleaved converter with built-in transformer voltage multiplier cells for sustainable energy applications,” *IEEE Trans. Power Electron.*, vol. 29, no. 6, pp. 2829–2836, Jun. 2014

[15] X. Hu and C. Gong, “A high voltage gain DC-DC converter integrating coupled-inductor and diode-capacitor techniques,” *IEEE Trans. Power Electron.*, vol. 29, no. 2, pp. 789–800, Feb. 2014.

[16] T. F. Wu, Y. S. Lai, J. C. Hung, and Y. M. Chen , “Boost converter with coupled inductors and buck–boost type of active clamp,” *IEEE Trans. Ind. Electron.*, vol. 55, no. 1, pp. 154–162, Jan. 2008

- [17] T. J. Liang, S. M. Chen, L. S. Yang, J. F. Chen, and A. Ioinovici, "Ultralarge gain step-up switched-capacitor DC-DC converter with coupled inductor for alternative sources of energy," *IEEE Trans. Circuits Syst.*, vol. 59, no. 4, pp. 864–874, Apr. 2012.
- [18] S. K. Changchien, T. J. Liang, J. F. Chen, and L. S. Yang, "Novel high step-up DC-DC converter for fuel cell energy conversion system," *IEEE Trans. Ind. Electron.*, vol. 57, no. 6, pp. 2007–2017, Jun. 2010.
- [19] Y. P. Hsieh, J. F. Chen, T. J. Liang, and L. S. Yang, "Novel high step-up DC-DC converter for distributed generation system," *IEEE Trans. Ind. Electron.*, vol. 60, no. 4, pp. 1473–1482, Apr. 2013.
- [20] L. S. Yang, T. J. Liang, H. C. Lee, and J. F. Chen, "Novel high step-up DC-DC converter with coupled-inductor and voltage-doubler circuits," *IEEE Trans. Ind. Electron.*, vol. 58, no. 9, pp. 4196–4206, Sep. 2011