

Separately Excited DC Motor Speed control of using various Tuning Conventional Controllers

Ujjwal Kumar ¹, Devendra Dohare²

¹ M.Tech Student, Department of Electrical Engineering MPCT Gwalior (India)

² Assistant professor, Department of Electrical Engineering MPCT Gwalior (India)

Abstract - DC motors are used extensively in industrial variable speed applications because of most demanding speed-torque characteristics and are simple in controlling aspects. This paper presents the most commonly used controller in the industry field is the proportional integral (PI) and proportional integral derivative (PID) controller. The purpose of this paper is to design a Ziegler-Nichols controller to improve the performance (speed) of the DC motor in order to control the angular speed of the motor. The results are compared with controller tuned by PI, PID and Ziegler-Nichols method. The results show the superiority Ziegler-Nichols method for separately excited DC motor speed control, which leads to improve the transient and steady state of speed responses of separately excited DC motor. The proposed method, is very efficient and could easily be extended for other global Techniques.

Key Words: Speed Control, DC Motor Model, PI Controller, PID Controller, Ziegler-Nichols method

1. INTRODUCTION

The development of high performance motor drives is very important in industrial as well as other purpose applications such as steel rolling mills, electric trains and robotics. Generally, a high performance motor drive system must have good dynamic speed command tracking and load regulating response to perform task. DC drives, because of their simplicity, ease of application, high reliabilities, flexibilities and favorable cost have long been a backbone of industrial applications, robot manipulators and home appliances where speed and position control of motor are required. DC drives are less complex with a single power conversion from AC to DC. Again the speed torque characteristics of DC motors are much more superior to that of AC motors. A DC motors provide excellent control of speed for acceleration and deceleration. DC drives are normally less expensive for most horsepower ratings. DC motors have a long tradition of use as adjustable speed machines and a wide range of

options have evolved for this purpose [1].DC motor plays a significant role in modern industrial. These are several types of applications where the load on the DC motor varies over a speed range. These applications may demand high-speed control accuracy and good dynamic responses [2].DC motors are considered as adjustable speed machine. Separately excited DC motor drive is the most suitable configuration used for variable speed applications for a long time due to its accurate speed control, controllable torque, high reliability and simplicity [3]. Today, industries are increasingly demanding for process automation in all sectors such as defence, industries, Robotics etc. DC motors have been used in variable speed drives. The versatile control characteristics of dc motors have contributed to their extensive use in industry. DC drives are less complex with a single power conversion from AC to DC. DC drives are normally less expensive for most horsepower ratings. DC motors have a long tradition of use as adjustable speed machines and a wide range of options have evolved for this purpose [4].

2. DC Motor Modeling and Simulation

Separately excited DC motors are most suitable for wide range speed control and are therefore used in many adjustable speed drives. DC motors are most suitable for wide range speed control and are therefore used in many adjustable speed drives. A DC motor can be seen to be comprised of three main parts: current carrying conductors called an armature; a circuit for magnetic field provided by magnets of poles; and a commutator that switches the direction of current in the armature as it passes a fixed point in space In order to build the DC motors transfer function its simplified mathematical model has been used. The equivalent circuit of separately excited DC motor is show in the fig 1 [4].

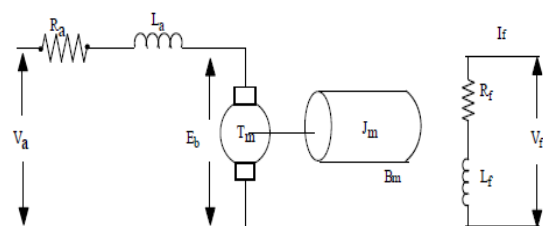

Fig 1 the equivalent circuit of separately excited DC motor

Where

Va= Armature Voltage in volt

Ra= Armature Resistance in Ohm

La=Armature Inductance in Henry

Ia=Armature Current in Amp

Eb= Back EMF in Volt

Tm=Mechanical Torque in N-m

Jm= Moment of Inertia Kg-m2

Bm=Damping Coefficient Nm.Sec

If= Field Current in Amp

Lf= Field Inductance in Henry

Vf= Field Voltage in Volt

For this purpose assuming Load torque TL=0, And friction torque Tf=0, since neither affects the transfer Function.

The transfer function of DC motor speed with respect to the input voltage can be written as follows,

$$\frac{\theta(s)}{V_a(s)} = \frac{K_m}{(Js + b)(L_m s + R_m) + K_m^2}$$

Selection of motor parameters

The DC motor under study has the following specification and parameters.

1. Specifications:

3hp, 230V, 11Amp, 1500 rpm

2. Parameters:

Ra=2.45ohm,La=0.2145 H,Kb=1.05volt/rad/sec, J=5kgm2, B=0.0859 N/rad/sec.

3. Different Tuning method

Speed of DC motor can be controlled using different tuning methods and are as follows:-

- 3.1 Speed control of DC motor using PI Controller
- 3.2 Speed control of DC motor using PID Controller
- 3.3 Speed control of DC motor using Z-N Method

3.1 Speed control of DC motor using PI Controller

The P-I controller has a proportional as well as an integral term in the forward path, The integral controller has the property of making the steady state error zero for a step change, although a P-I controller makes the steady state error zero, Since most of the process cannot work with an offset, they must be controlled at their set points and in order to achieve this, extra intelligence must be added to proportional controller and this is achieved by providing an integral action to the original proportional controller. So the controller becomes proportional –Integral controller [5].in this paper use MATLAB Simulink model of DC motor using PI Controller shows in the fig 2.

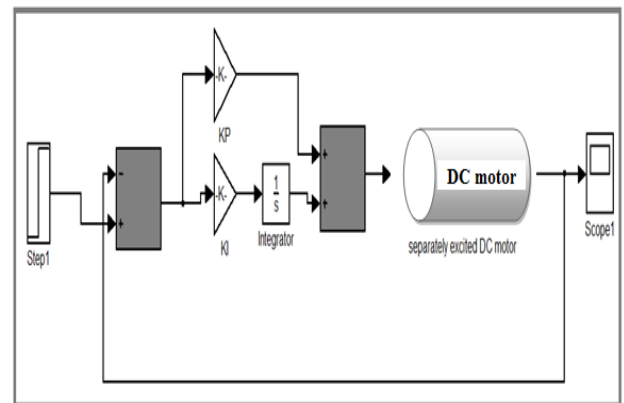

Fig 2 MATLAB Simulink model of DC motor using PI Controller

3.2 Speed control of DC motor using PID Controller

The PID control is most widely used in industrial applications. It is implemented to control the speed of DC motor which is shown in Fig.2. The error between the reference speed and the actual speed is given as input to a PID controller. The PID controller depending on the error changes its output, to control the process input such that the error is minimized. Detailed information about the theory and tuning of PID controllers is given in [6][7].The combination of proportional, integral and derivative control action is called PID control action. PID controllers are commonly used to regulate the time-domain behavior of many different types of dynamic plants. These controllers are extremely popular because they can usually provide good closed-loop response characteristics. Consider the feedback system architecture that is shown in Fig. 3 where it can be assumed that the plant is a DC motor whose speed must be accurately regulated. In this paper use MATLAB Simulink model of DC motor using PID Controller show in the fig 3.

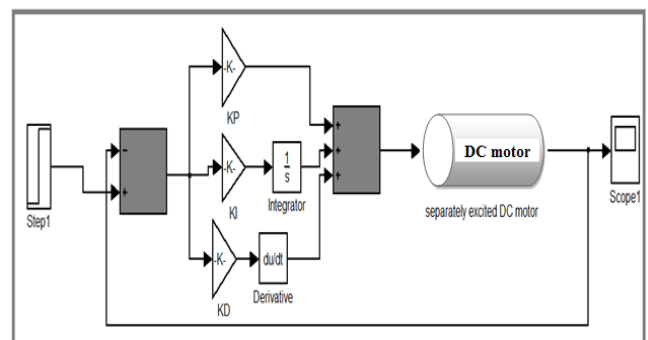

Fig 3 MATLAB Simulink model of DC motor using PID Controller

The PID controller is placed in the forward path, so that its output becomes the voltage applied to the motor's armature the feedback signal is a velocity, measured by a

tachometer .the output velocity signal C (t) is summed with a reference or command signal R (t) to form the error signal e (t). Finally, the error signal is the input to the PID controller

$$u = k_p e + k_i \int e dt + k_d \frac{de}{dt}$$

The corresponding three adjustable PID parameters are most commonly selected to be

- Controller gain- (increased value gives more proportional action and faster control)
- Integral time- (decreased value gives more integral action and faster control)
- Derivative time- (increased value gives more derivative action and faster control)

Although the PID controller has only three parameters, it is not easy, without a systematic procedure, to find good values (tunings) for them. In fact, a visit to a process plant will usually show that a large number of the PID controllers are poorly tuned

3.3 Speed control of DC motor using Z-N Method

One of the most widely used method for the tuning of the PID controller gains is to use the open loop response as inferred by Ziegler-Nichols(ZN), yet this method is limited for application till the ratio of 4:1 for the first and the second peaks in the closed loop response[8], leading towards an oscillatory response. Ziegler and Nichols proposed two experimental approaches to quickly adjust the controller parameters without knowing the precise dynamic model of the system to adjust. Both methods are empirical and based on tests. In this paper we use the second method of Ziegler-Nichols, it is a simple technique to tuning P, I, D controller parameters [9][10]. Ziegler and Nichols presented two methods, a step response method and a frequency response method. The step response method is based on an open-loop step response test of the process, hence requiring the process to be stable. The open loop system's S shaped response is characterized by the parameters, namely the process time constant T and L. These parameters are used to determine the controller's tuning parameters. The second method of Z-N tuning is closed-loop tuning method that requires the determination of the ultimate gain and ultimate period. The method can be interpreted as a technique of positioning one point on the Nyquist curve. This can be achieved by adjusting the controller gain (Ku) till the system undergoes sustained oscillations (at the ultimate gain or critical gain), whilst maintaining the integral time constant (Ti) at infinity and the derivative time constant (Td) at zero. In this paper use MATLAB Simulink model of DC motor using PID Controller show in the fig 4.

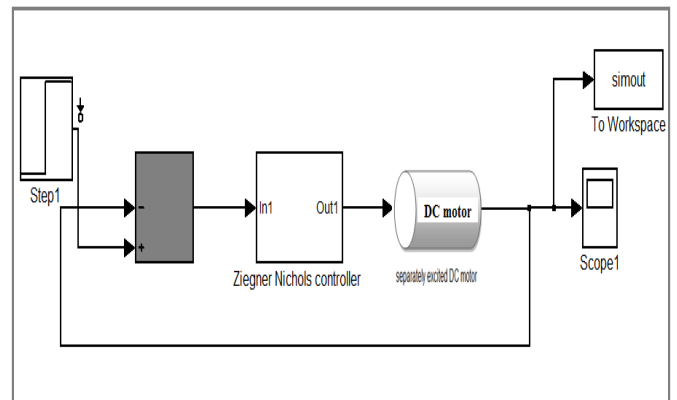

Fig 4 MATLAB Simulink model of DC motor using Ziegler-Nichols Controller

4. MATLAB SIMULATION RESULTS

In this paper, a dynamic model of a separately excited DC motor has been designed and implemented in MATLAB along with the PI controller, PID controller and Ziegler-Nichols controller. separately excited DC motor MATLAB simulink model show in the fig 2 fig 3 and fig 4 ,Response of PI controller , PID controller and Ziegler-Nichols show in the fig 5 .fig 6,fig 7,The better results have been presented in Table 1 and combined all controller response show in the fig 8.

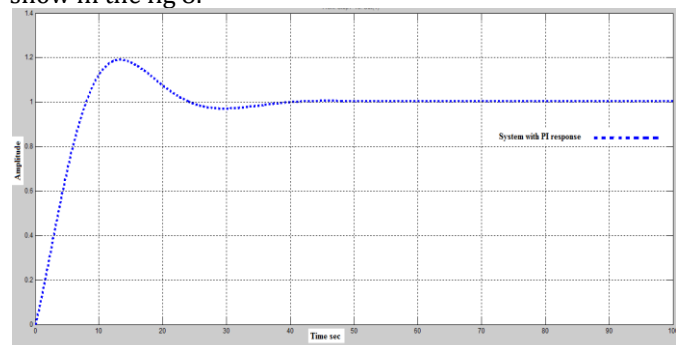

Fig.5 Step response of system with PI controller

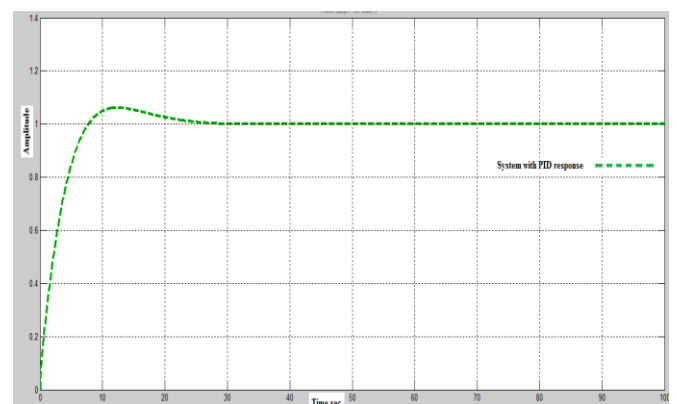

Fig.6 Step response of system with PID controller

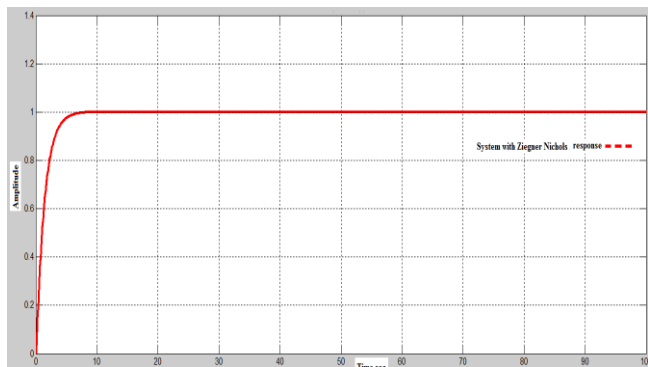

Fig.7 Step response of system with Ziegler-Nichols controller

Table.1 Comparisons of Step Response PI, PID and ZIEGLER-NICHOLS

Comparison between PI, PID, And Ziegler-Nichols	TUNING METHODS		
	PI RESPONSE	PID RESPONSE	ZIEGLER-NICHOLS RESPONSE
Rise time (s)	6.01	4.99	2.95
Settling time(s)	34.1	20.4	5.28
Peak time (s)	1.19	1.06	1.00
Overshoot (%)	19	6.17	0.0446
STEP RESPONSE	STABLE	STABLE	MORE STABLE

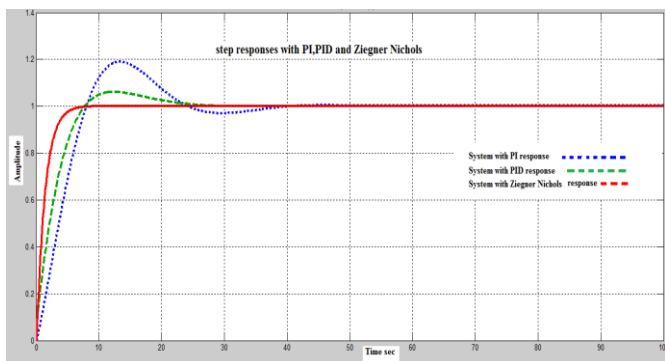

Fig 8 Compared Response of PI, PID and Ziegler-Nichols controller

5. CONCLUSIONS

In this paper Simulation results it is concluded that, compared with the conventional PI controller, PID controller and Ziegler-Nichols has a performance in both transient and steady state response. The Ziegler-Nichols controller has better dynamic response, shorter response time, small overshoot, and small steady state error then PI controller, PID controller.

REFERENCES

[1]Miss. Pranoti Khanke*, Assi. Prof. Sangeeta Jain**, "Speed control of Separately Excited DC Motor using various Conventional Controllers" Miss. Pranoti Khanke Int. Journal of Engineering Research and Applications Vol. 5, Issue 4, (Part -3) April 2015.

[2]Shashi Bhushan Kumar, Mohammed Hasmat Ali*, Anshu Sinha**, "Design and Simulation of Speed Control of DC Motor by Artificial Neural Network Technique" International Journal of Scientific and Research Publications, Volume 4, Issue 7, July 2014.

[3] Muhammad Rafay Khan, "Speed Control of DC Motor under Varying Load Using PID Controller" International Journal of Engineering (IJE), Volume (9) : Issue (3) : 2015.

[4] Ms.Manjusha Patil, "Modelling and simulation of dc drive using PI and PID controller", International Journal Of Innovative Research In Electrical, Electronics, Instrumentation And Control Engineering Vol. 2, Issue 12, December 2014.

[5] J. C. Basilio and S. R. Matos, "Design of PI and PID Controllers With Transient Performance Specification", " IEEE Trans. Education, vol. 45, Issue No. 4, 2002, pp. 364-370.

[6] Dr.Ch.Chengaiyah1, K.Venkateswarlu2, "Comparative Study on Dc Motor Speed Control Using Various Controllers" International Journal of Advanced Research in Electrical, Electronics and Instrumentation Engineering Vol. 3, Issue 1, January 2014.

[7] Sanju Saini and Arvind Kumar "Speed Control of Separately Excited D.C Motor using Self Tuned ANFIS Techniques" IJCST Vol. 3, Issue 1, Jan. - March 2012.

[8] Nitish Katal, "Optimizing Response of PID Controller for Servo DC Motor by Genetic Algorithm" International Journal of Applied Engineering Research, ISSN 0973-4562 Vol. 7 No.11 (2012).

[9]P.M.Meshram, Rohit G. Kanojiya, "Tuning of PID Controller using ziegler-nichols method for Speed Control of DC motor",IEEE international confrence on advanced inengineering, science and management (ICAESM-2012) march 30,31,2012,

[10] G. Sudha, Dr.R. Anita, "Performance Based Comparison between Various Z-N Tuning PID and Fuzzy Logic PID Controller in Position Control System of DC motor" inproc. International Journal on soft computing (IJSC) vol.no.3, August2012.

content here. Paragraph comes content here. Paragraph comes content here. Paragraph comes content here. Paragraph comes content here. Paragraph comes content here. Paragraph comes content here. Paragraph