

Controller Design Using ANFIS-Based Estimation Method for Unmodeled Dynamics

M. Jyosthna Bai¹, K.Sailaja²

¹ PG Scholar, Department of EEE, JNTU Anantapur, Andhra Pradesh, India

² PG Scholar, Department of EEE, JNTU Anantapur, Andhra Pradesh, India

Abstract— A Nonlinear system is represented as a combination of linear part and Unmodeled Dynamics. The unmodeled dynamics is estimated by using ANFIS. At first the unmodeled dynamics is divided into two parts by using differential expansion of the control input at the last time instant, then the two parts are estimated by using ANFIS. This method improves the precision of Unmodeled Dynamics. Second to deal with the input and output of the unmodeled dynamics one to one mapping and regularization techniques are used with an assumption that growth rate of unmodeled dynamics does not exceed its input vector from which the data vector lies inside the compact set. The datum of the system is fully used to obtain the parameters (centers and widths) in membership functions that are considered as network connection weights in ANFIS offline training. These parameters are tuned online to improve estimation convergence rate. Finally the proposed estimation method is applied to nonlinear switching control design. By the simulation results it is proved that the nonlinear switching control that adopts the proposed estimation method provides stability and convergence of the system that exhibits a desired dynamic performance for the closed loop system.

Keywords—Adaptive neuro-fuzzy inference system (ANFIS), data, nonlinear systems, switching control, unmodeled dynamics.

1. INTRODUCTION

Complex industrial processes have several difficulties like unknown structure, time-varying, and uncertain disturbance making the mathematical models difficult to be established. A low order linear model can be established from input and output data around the corresponding operating point. This would inevitably lead to the unmodeled dynamics because of the mismatching between the controller design model and the actual controlled plant which reduces the control effect. Hence, the obtained unmodeled dynamics can be estimated accurately and compensated effectively by designing a nonlinear controller with an estimator so that a satisfactory control effect can be maintained. To

estimate the unmodeled dynamics accurately the following issues are considered:

- Due to the current instant control input $u(k)$ being embedded in unmodeled dynamics and the true input data vector of unmodeled dynamics, the true value of unmodeled dynamics and the real time tuning are difficult to obtain.
- The input and output data for the network cannot be guaranteed as uniformly bounded.

There are two main methods to solve the problem when the unmodeled dynamics contains unknown control input $u(k)$

- Newton Iteration Method
- The last instant value $u(k-1)$ of the controller is used to replace its current unknown value directly.

These approaches are feasible for a class of unmodeled dynamics which is relatively small or tends to be at steady state when the time reaches infinity. The unmodeled dynamics of complex industrial plant, regardless of which of the approximation properties are used leads to the big estimation errors which will affect the control effect and even cause the closed loop system unstable. Hence, an Improved Estimation algorithm is developed for the unmodeled dynamics that is based on the Adaptive Neuro Fuzzy Inference System (ANFIS).

2. DESCRIPTION OF UNMODELED DYNAMICS:

Single-input and single-output complex industrial plants which are difficult to be described by accurate mathematical models can be expressed in the following nonlinear form

$$y(k+1) = f[y(k), \dots, y(k-m_s+1), u(k), u(k-1), \dots, u(k-m_s)] + d(k) \quad (1)$$

where the delay of the system is selected as 1, $u(k) \in \mathbb{R}$ and $y(k) \in \mathbb{R}$ are the system input and output at sample time k , respectively. It is assumed that the structure

orders (n_s, m_s) are unknown and that $f(\cdot):R^{n_s+m_s} \rightarrow R$ is an unknown and smooth nonlinear function and limited to a class of systems in the sense that system (1) can be expressed as a linear system and an unmodeled dynamics near the operating points. $d(k)$ denotes a bounded disturbance, which can include the measurement noise and unmeasured disturbances, and is assumed to be bounded and uncorrelated with the inputs [1] i.e., $|d(k)| \leq d_0$, where $d_0 > 0$ is a known constant.

Since complex industrial plants often operate near an operating point, the following low-order linear model can be used for their controller design around the corresponding operating point. The output of the low-order linear model is denoted by $y^*(k+1)$ and can be expressed as follows:

$$y^*(k+1) = -a_0 y(k) - \dots - a_{n_a} y(k - n_a + 1) + b_0 u(k) + \dots + b_{n_b} u(k - n_b) \tag{2}$$

Where $\{a_0, \dots, a_{n_a}, b_0, \dots, b_{n_b}\}$ are the parameters of the linear model.

Since the controller design model (2) does not take into account the impact of nonlinear part of the original system, there are some mismatches between the structure and parameters for the dynamic characteristics of the controlled system (1). This would inevitably lead to a dynamic tracking error between the output of the closed-loop system and the output of low-level controller design model. The error is defined as unmodeled dynamics. The unmodeled dynamics is defined as unknown nonlinear function and includes various disturbances and the error between the low-level controller design model and the original system. The unmodeled dynamics is defined as follows:

$$v[x(k)] = f[\cdot] + d(k) - y^*(k+1) \tag{3}$$

where $x(k) = [u(k), \dots, u(k - n_b), y(k), \dots, y(k - n_a + 1)]^T$. From (2) and (3), it can be seen that system (1) can be equivalently expressed as the form of a linear controller design model plus unmodeled dynamics as follows:

$$y(k+1) = y^*(k+1) + v[x(k)] \\ = -a_0 y(k) - \dots - a_{n_a} y(k - n_a + 1) + b_0 u(k) + \dots + b_{n_b} u(k - n_b) + v[x(k)] \tag{4}$$

Using the unit delay operator, z^{-1} (i.e., $z^{-1}y(k+1) = y(k)$), (4) can be written as

$$A(z^{-1})y(k+1) = B(z^{-1})u(k) + v[x(k)] \tag{5}$$

where $A(z^{-1})$ and $B(z^{-1})$ are polynomials in terms of the unit back shift operator z^{-1} with structure orders being given by n_a and n_b . These structure orders are prespecified by designers and are assumed to satisfy $0 < n_a \leq n_s, 0 < n_b \leq m_s$. In this context, the specific expression of $A(z^{-1})$ and $B(z^{-1})$ can be denoted as

$$A(z^{-1}) = 1 + a_0 z^{-1} + \dots + a_{n_a} z^{-n_a}$$

$$B(z^{-1}) = b_0 + b_1 z^{-1} + \dots + b_{n_b} z^{-n_b}$$

3. STRUCTURE OF A CONTROLLER WITH A COMPENSATOR OF UNMODELED DYNAMICS :

In [2], [3], [4], and [5], several new control methods are proposed. In Fig.1, the nonlinear compensator K is employed to suppress the influence of the unmodeled dynamics to the control input.

It can be seen from Fig. 1 that the control input $u(k)$ can be calculated from

$$u(k) = H^{-1}(z^{-1})\{R(z^{-1})\omega(k+1) - G(z^{-1})y(k) - kv[x(k)]\}$$

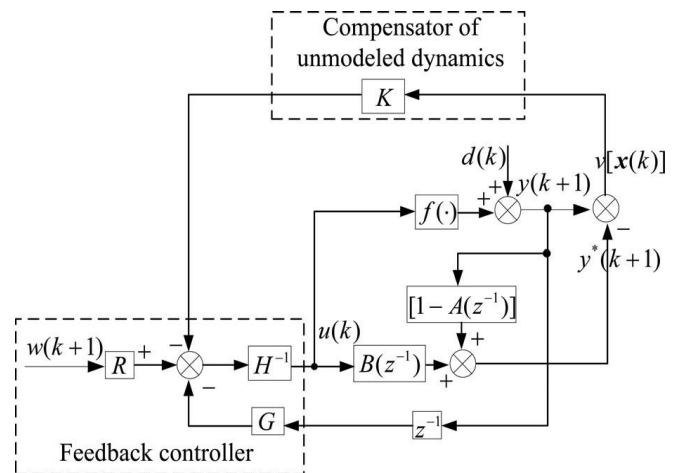

Fig1: Structure of controller with a compensator of unmodeled dynamics.

From (6), it can be seen that the control input $u(k)$ not only relies on the output $y(k)$ and reference input $w(k)$, but also depends on the unmodeled dynamics $v[x(k)]$. Since the unmodeled dynamics $v[x(k)]$ is unknown and control input $u(k)$ is embedded inside $v[x(k)]$, the above controller cannot be realized in practice. To solve the problem and implement this controller, $v[x(k)]$ must be estimated and the estimated value of $\hat{v}[x(k)]$ is used to replace $v[x(k)]$. As a result, a controller (6) is changed into the following form:

$$u(k) = H^{-1}(z^{-1})\{R(z^{-1})\omega(k+1) - G(z^{-1})y(k) - \hat{v}[x(k)]\} \quad (7)$$

Substituting the above controller (7) into controlled plant (5), the following closed-loop system equation can be obtained

$$[H(z^{-1})A(z^{-1}) + z^{-1}B(z^{-1})G(z^{-1})]y(k+1) = R(z^{-1})B(z^{-1})\omega(k+1) + H(z^{-1})v[x(k)]B(z^{-1})K\hat{v}[x(k)] \quad (8)$$

From (8), it can be seen that the polynomials of a controller $H(z^{-1})$, $G(z^{-1})$, and $R(z^{-1})$ can be designed using different methods. The influence of unmodeled dynamics to the output of the closed-loop system can be either eliminated or reduced by designing compensator K appropriately.

In general, the purpose of design compensator K is to make the difference between $H(z^{-1})v[x(k)]$ and $B(z^{-1})K\hat{v}[x(k)]$ as small as possible. When $B(z^{-1})$ is minimum phase, one can design compensator K as a polynomial in terms of the unit back shift operator z^{-1} [i.e., $K(z^{-1})$] such that $H(z^{-1}) = B(z^{-1})K(z^{-1})$. In this case, it can be obtained that

$$H(z^{-1})v[x(k)] - B(z^{-1})K(z^{-1})\hat{v}[x(k)] = B(z^{-1})K(z^{-1})\{v[x(k)] - \hat{v}[x(k)]\} \quad (9)$$

From (9), it can be evidently seen that the smaller the $|v[x(k)] - \hat{v}[x(k)]|$, the smaller the influence of the unmodeled dynamics $v[x(k)]$ would be to the closed-loop system, and thus a better performance of the closed-loop system can be obtained.

4. STRUCTURE OF UNMODELED DYNAMICS

The ANFIS is used to estimate the unmodeled dynamics of the system. By the definition of unmodeled dynamics, $v[x(k)]$ is an unknown and nonlinear function with respect to the input data vector $x(k)$, and $x(k)$ also includes the unknown control input $u(k)$ yet to be designed and calculated. The following structure is proposed:

First of all, data vector $x(k)$ can be expressed as follows:

$$x(k) = [u(k), \bar{x}(k)]$$

where

$$\bar{x}(k) = [u(k-1), \dots, u(k-n_b), y(k), \dots, y(k-n_a)]^T \quad (10)$$

$v[x(k)]$ can be considered as the binary function about $u(k)$ and $\bar{x}(k)$ and can be further written in the following form

$$v[u(k), \bar{x}(k)] = v[u(k) - u(k-1) + u(k-1), \bar{x}(k)] = v[u(k-1) + \Delta u(k), \bar{x}(k)] \quad (11)$$

According to (11), via the use of the total differential formula of $v[u(k), \bar{x}(k)]$ with respect to $[u(k-1), \bar{x}(k)]$, $v[u(k), \bar{x}(k)]$ can be expressed as follows:

$$v[u(k), \bar{x}(k)]$$

$$= v[u(k-1), \bar{x}(k)] + \frac{\partial v[u(k), \bar{x}(k)]}{\partial u(k)} \Big|_{u(k)=u(k-1)} \cdot \Delta u(k) + o[|\Delta u(k)|] = v_1(k) + v_2(k) \cdot \Delta u(k) + o[|\Delta u(k)|] \quad (12)$$

where Δ is the increment operator, and $\Delta u(k) = u(k) - u(k-1)$

$$v_1(k) = v[u(k-1), \bar{x}(k)] \quad (13)$$

$$v_2(k) = \frac{\partial v[u(k), \bar{x}(k)]}{\partial u(k)} \Big|_{u(k)=u(k-1)} \quad (14)$$

where $o[|\Delta u(k)|]$ is a higher order infinitesimal than $|\Delta u(k)|$ when $|\Delta u(k)| \rightarrow 0$. It is assumed that $o[|\Delta u(k)|]$ is bounded, i.e., $|o[|\Delta u(k)|]| \leq d_1$ and d_1 is a constant.

If $o[|\Delta u(k)|]$ is ignored, then it can be obtained that $v[u(k), \bar{x}(k)] = v_1(k) + v_2(k) \cdot \Delta u(k)$ (15)

From (12)–(14), it can be seen that although data vector contains the unknown control input $u(k)$, the unknown $u(k)$ can be replaced by its known value at previous instant time $u(k-1)$ by replacing $u(k) = u(k-1)$, which makes the influence of unknown input $u(k)$ to the unmodeled dynamics $v[x(k)]$ decrease as small as possible.

5. ESTIMATION ALGORITHM OF UNMODELED DYNAMICS

The estimation algorithm is done in five stages as shown in Fig. (2) and is described as follows:

5.1. DATA PROCESSING:

From (13), it can be seen that $v_1(k)$ is decided by the input data vector $[u(k-1), \bar{x}(k)]$. In order to ensure the property of universal approximation of the ANFIS, it must guarantee that the input data vector $[u(k-1), \bar{x}(k)]$ is inside a compact set. Hence, the one-to-one mapping α can be applied to $[u(k-1), \bar{x}(k)]$ to obtain $[\tilde{u}(k-1), \tilde{x}(k)]$

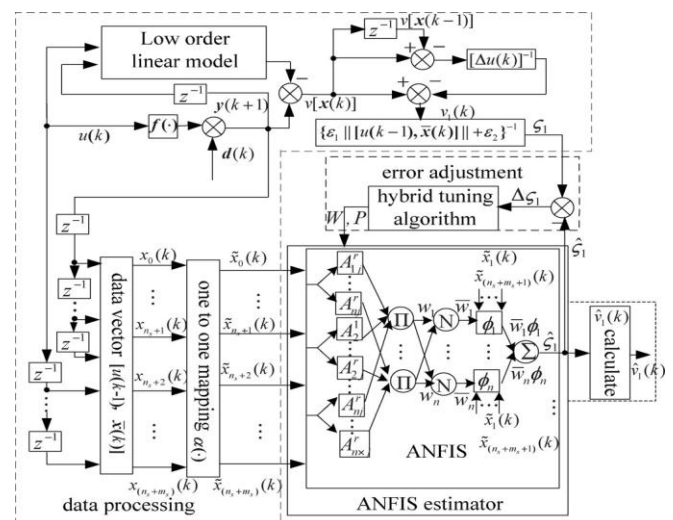

Fig2: Structure of the estimation for unmodeled dynamics of $v_1(k)$

The i^{th} component of $\bar{x}(k)$ is denoted as $\bar{x}_i(k)$ which can be calculated from

$$\bar{x}_i(k) = \alpha[\bar{x}_i] = \frac{1}{1 + \exp[-\bar{x}_i]} \quad i = 1, 2, \dots, (n_a + n_b + 1) \quad (16)$$

In particular, when $i = 1$

$$\begin{aligned} \bar{x}_1(k) &= \alpha[x_1(k)] = \tilde{u}(k - 1) \\ &= \frac{1}{1 + \exp[-u(k - 1)]} \end{aligned} \quad (17)$$

From (16), it can be seen that $\bar{x}_i(k) \in (0, 1) \in [0, 1], i = 1, 2, \dots, (n_a + n_b + 1)$

This means that $\bar{x}_i(k)$ is in a compact set.

5.2 ANFIS-BASED ESTIMATOR FOR $v_1(k)$:

In order to construct the ANFIS-based estimator, $[\tilde{u}(k - 1), \bar{x}(k)]$ is first fuzzified, where the i^{th} component $[\tilde{u}(k - 1), \bar{x}(k)]$ is divided into m_1 fuzzy set. The j^{th} fuzzy set of \bar{x}_i is represented by $A_{ij} (j = 1, 2, \dots, m_1)$ with the following membership function:

$$\rho_{ij}(\bar{x}_i(k)) = \exp\left[-\frac{(\bar{x}_i(k) - c_{ij})^2}{2(\sigma_{ij})^2}\right] \quad (18)$$

where c_{ij} and σ_{ij} are the centers and width of the membership function, respectively, and they are tuned based on the estimation error. Second, we need to set the learning and training number n for each group data of the ANFIS. Using the previous fuzzification, a number of $m = m_1 \times (n_a + n_b + 1)$ fuzzy rules can be obtained, where any rule denoted by $R^r (r = 1, \dots, m)$ can be expressed by the T-S fuzzy model.

Consequently, using the method of weighting average defuzzification, the estimation for $\zeta_1(k)$ is given by

$$\hat{\zeta}_1 = \sum_{r=1}^m \bar{\omega}_r(k) \phi_r(k) \quad (19)$$

where the weighting coefficients $\bar{\omega}_r(k) (r = 1, \dots, m)$ are the usage degrees which are obtained by using normalized fuzzy rules. In this context, $\bar{\omega}_r(k)$ is linking weight which is used from antecedent (the part of "if" in fuzzy rule) of the fuzzy rule to consequent (the part of "then" in fuzzy rule) and can be computed by the following formula:

$$\bar{\omega}_r(k) = \frac{\omega_r(k)}{\sum_{r=1}^m \omega_r(k)} \quad (20)$$

where $\omega_r(k)$ is the fitness of each fuzzy rule and is obtained by singleton fuzzifier. They are used to match the antecedent of the fuzzy rules and can be calculated as follows:

$$\omega_r(k) = \prod_{i=1}^{(n_a + n_b + 1)} \rho_{ij}^r(\bar{x}_i(k)) \quad (21)$$

where the parameters c_{ij}^r and σ_{ij}^r in membership function $\rho_{ij}^r(\bar{x}_i(k))$ are tuned again using the estimation error.

Assuming that $v_1(k)$ satisfies the following condition:

Condition 1:

$$|v_1(k)| \leq ||[u(k - 1), \bar{x}(k)]|| + \varepsilon_2 \quad \forall k \quad (22)$$

ε_1 and ε_2 are constants chosen offline via a trial-and-error method so that they satisfy inequalities: $0 \leq \varepsilon_1 < 1, \varepsilon_2 \geq 0$.

According to Condition 1, in order to make ANFIS approach $v_1(k)$, a normalization of $v_1(k)$ can produce $\zeta_1(k)$, and it should satisfy $\zeta_1(k)$ and it should satisfy $|\zeta_1(k)| \leq 1$.

Therefore, the following can be obtained

$$\zeta_1(k) = \frac{v_1(k)}{\varepsilon_1 ||[u(k - 1), \bar{x}(k)]|| + \varepsilon_2} \quad (23)$$

Using (16) and (23) it can be obtained that the input data and target value to the ANFIS are all in a compact set $[0, 1]$, which ensure the condition for a universal approximation theorem of the ANFIS. We can then use the input and output data:

$\{[\tilde{u}(k - 1), \bar{x}(k)], \zeta_1(k)\}$ to sufficiently train the ANFIS offline so that the following error performance index can be minimized

$$E = \frac{1}{2} \Delta \zeta_1^2 \quad (24)$$

where $\Delta \zeta_1 = \zeta_1(k) - \hat{\zeta}_1(k)$ and $\hat{\zeta}_1(k)$ is the estimation value of $\zeta_1(k)$. The ideal initial value for c_{ij}, σ_{ij} and ρ_{ij}^r in the ANFIS can be selected using the above offline training.

5.3. ANFIS-BASED ESTIMATOR FOR $v_2(k)$:

Using (14), it is implied that the input data vector to train the ANFIS to estimate $v_2(k)$ is same as $v_1(k)$. Therefore, similar to the method of estimating $v_1(k)$, $\hat{v}_2(k)$ can be obtained by determining the initial

parameters in the ANFIS and the only difference is that the target value for $v_2(k)$ is given by

$$v_2(k) = \frac{v[u(k), \bar{x}(k)] - v_1(k)}{\Delta u(k)} \tag{25}$$

5.4. Estimation Of Unmodeled Dynamics:

From(23), it can be concluded that

$$v_1(k) = \zeta_1(k) (\varepsilon_1 || [u(k-1), \bar{x}(k)] || + \varepsilon_2) = \zeta_1(k) (\varepsilon_1 || \alpha^{-1} [\bar{u}(k-1), \bar{x}(k)] || + \varepsilon_2) \tag{26}$$

Therefore, $\hat{v}_1(k)$ can be obtained as follows:

$$\hat{v}_1(k) = \zeta_1(k) (\varepsilon_1 || \alpha^{-1} [\bar{u}(k-1), \bar{x}(k)] || + \varepsilon_2)$$

Where

$$\alpha^{-1} [\bar{u}(k-1), \bar{x}(k)] = [\alpha^{-1}(\bar{x}_1(k)), \dots, \alpha^{-1}(\bar{x}_i(k)), \dots, \alpha^{-1}(x_{(n_a+n_b+1)}(k))] \tag{27}$$

As such, the following equality can be formulated from (3.7)

$$\alpha^{-1}(\bar{x}_i(k)) = -\ln\left(\frac{1}{\bar{x}_i(k)} - 1\right) \tag{28}$$

Similar to the above formulation, the estimated value $\hat{v}_2(k)$ of $v_2(k)$ can be obtained.

Taking the estimated values $\hat{v}_1(k)$ and $\hat{v}_2(k)$ of $v_1(k)$ and $v_2(k)$ respectively, into controller (7), the controller can, therefore, be changed into the following form:

$$u(k) = [H(z^{-1}) + k(z^{-1})\hat{v}_2(k)]^{-1} \times [R(z^{-1})w(k) - G(z^{-1})y(k) - K(z^{-1})\hat{v}_1(k) + K(z^{-1})\hat{v}_2(k) \cdot u(k-1)] \tag{29}$$

According to the controller (29), $u(k)$ can be computed. As a result, the estimated value for $v[x(k)]$ can be expressed as follows:

$$\hat{v}[u(k), \bar{x}(k)] \approx \hat{v}_1(k) + \hat{v}_2(k) \cdot \Delta u(k) \tag{30}$$

5.5. TUNING OF THE ESTIMATION ERROR:

In order to obtain good estimation, the ANFIS should be tuned at real time. However, due to the time delay of the system, it is impossible to implement this in a real-time manner. Therefore, we adopt the strategy that estimates the unmodeled dynamics first and corrects the ANFIS at next instant. That is to say, at the next time instant $k + 1$, it can be obtained that the output of the closed-loop system is $y(k+1)$ when the controller $u(k)$ is used in time instant k . At the same time, substituting the following linear controller into the lower order system (2), the output $y^*(k + 1)$ can be obtained. As a result, the unmodeled dynamics $v[x(k)]$ can be obtained by (3).

Since $v[x(k)]$ is continuous with respect to $u(k)$ and $u(k - 1)$, it can be concluded that

$$\lim_{\Delta u(k) \rightarrow 0} \frac{\Delta v[x(k)]}{\Delta u(k)} \approx \frac{\partial v[u(k), \bar{x}(k)]}{\partial u(k)} \Big|_{u(k)=u(k-1)} \tag{31}$$

Where $\Delta v[x(k)] = v[x(k)] - v[x(k-1)]$.

Therefore, the approximated value for $v_2(k)$ can be obtained from the following formula:

$$v_2(k) \approx \frac{\Delta v[x(k)]}{\Delta u(k)} \tag{32}$$

From (15), the approximated value of $v_1(k)$ can be obtained to give

$$v_1(k) = v[x(k)] - v_2(k) \Delta u(k) \tag{33}$$

Normalization of $v_1(k)$ can produce $\zeta_1(k)$. Therefore, from the above formulation, it can be seen that the estimation error tuning signal is given by

$$\Delta \zeta_1 = \zeta_1(k) - \hat{\zeta}_1(k) \tag{34}$$

Therefore, the tuning of p_{ij}^r can be obtained to read

$$\Delta \zeta_1(k) = \zeta_1(k) - \sum_{r=1}^m [\bar{\omega}_r \sum_{i=0}^{n_a+n_b+1} p_{ij}^r \bar{x}_i(k)] \tag{35}$$

or a fixed $\bar{\omega}_r$, the recursive least square estimation in [6] can be used to evaluate the tuned value $p_{ij}^r(k)$ for p_{ij}^r . Using the tuned value of $p_{ij}^r(k)$, c_{ij}^r and σ_{ij}^r can also be adjusted online.

For this purpose, the following performance index is defined:

$$E = \frac{1}{2} \Delta \zeta_1^2 = \frac{1}{2} \left[\zeta_1(k) - \sum_{r=1}^m \frac{\bar{\omega}_r \sum_{i=0}^{n_a+n_b+1} p_{ij}^r \bar{x}_i(k)}{\sum_{i=1}^m \prod_{i=1}^{(n_a+n_b+1)} \exp \left[-\frac{(x_i(k) - c_{ij}^r(k))^2}{2(\sigma_{ij}^r)^2} \right]} \right]^2 \tag{36}$$

Using the gradient descent rules in to minimize (36), the adjust value for c_{ij}^r can be obtained to give $c_{ij}^r(k)$. Using both $c_{ij}^r(k)$ and $p_{ij}^r(k)$ and the following equation:

$$E = \frac{1}{2} \left[\zeta_1(k) - \sum_{r=1}^m \frac{\bar{\omega}_r \sum_{i=0}^{n_a+n_b+1} p_{ij}^r \bar{x}_i(k)}{\sum_{i=1}^m \prod_{i=1}^{(n_a+n_b+1)} \exp \left[-\frac{(x_i(k) - c_{ij}^r(k))^2}{2(\sigma_{ij}^r)^2} \right]} \right]^2 \tag{37}$$

The adjusted value for σ_{ij}^r can be readily obtained by minimizing the above performance index using again the gradient rule

5.6 NONLINEAR SWITCHED CONTROL APPLICATION:

The algorithm of nonlinear switching control is proposed in [5]. The controller and switching mechanism are designed in [5]. In Fig. 3, c_1 denotes a linear controller given by

$$[F(z^{-1})B(z^{-1}) + Q(z^{-1})]u(k) = R(z^{-1})w(k + 1) - G(z^{-1})y(k)$$

And c_2 represents a nonlinear controller of the following form :

$$[F(z^{-1})B(z^{-1}) + Q(z^{-1})]u(k) = R(z^{-1})w(k+1) - G(z^{-1})y(k) - [F(z^{-1}) + K(z^{-1})]v[x(k)]$$

Where $F(z^{-1}), Q(z^{-1}) = \lambda_1(1-z^{-1}), K(z^{-1}) = \lambda_2(1-z^{-1})$, and $G(z^{-1})$ are controller weighting polynomials about the unit back shift operator z^{-1} . λ_1 and λ_2 are constants chosen offline via a trial-and-error method. The specifically designed λ_1 and λ_2 are explained in detail in [5].

According to the method that is used to deal with the unmodeled dynamics, the previous nonlinear controller C_2 is changed into the following form:

$$[F(z^{-1})B(z^{-1}) + Q(z^{-1})]u(k) + [K(z^{-1}) + F(z^{-1})]v_2(k) \cdot \Delta u(k) = R(z^{-1})w(k+1) - G(z^{-1})y(k) - [K(z^{-1}) + F(z^{-1})]v_1(k)$$

Using the estimation values $\hat{v}_1(k)$ and $\hat{v}_2(k)$ to replace $v_1(k)$ and $v_2(k)$, respectively, the original nonlinear controller can be expressed in the following form:

$$[F(z^{-1})B(z^{-1}) + Q(z^{-1})]u(k) + [K(z^{-1}) + F(z^{-1})]\hat{v}_2(k) \cdot \Delta u(k) = R(z^{-1})w(k+1) - G(z^{-1})y(k) - [K(z^{-1}) + F(z^{-1})]\hat{v}_1(k)$$

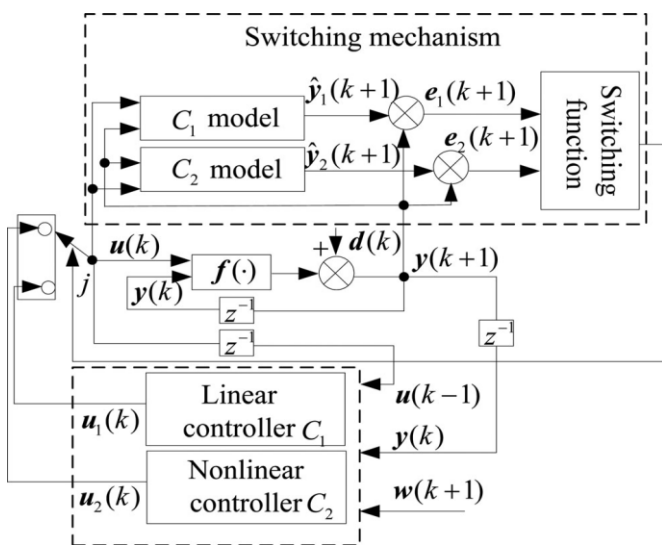

Fig3: Structure of Nonlinear switching control

Therefore, the control input can be computed to give

$$u(k) = \{ [F(z^{-1})R(z^{-1}) + Q(z^{-1}) + [K(z^{-1}) + F(z^{-1})]\hat{v}_2(k)]^{-1} \times \{ [K(z^{-1}) + F(z^{-1})]\hat{v}_2(k)u(k-1) + R(z^{-1})w(k+1) - G(z^{-1})y(k) - [K(z^{-1}) + F(z^{-1})]\hat{v}_1(k) \}$$

The switching function is

$$J_i(k) = \sum_{l=1}^k \frac{\mu_j l [c_j^2(l) - \gamma(k)^2]}{[1 + x(l-1)^T x(l-1)]} + c \sum_{l=k-N+1}^k [1 - \mu_j(l)] c_j^2(l)$$

$$\mu_j(k) = \{1, |e_j(k)| > \gamma(k)\}$$

When $j = 1$, $e_1(k)$ represents the estimation error for the linear controller C_1 based on the linear model. When $j =$

2, $e_2(k)$ stands for the estimation error of the nonlinear controller C_2 that is based on the nonlinear model. In the previous equation, $c \geq 0$, and N is a predefined positive number.

The objective of control design is to obtain a bounded control signal $u(k)$ such that

1) The input and output signals of the closed-loop system are uniformly bounded when the controller is applied (i.e., bounded input and bounded output (BIBO));

2) The obtained controller should make the output of the closed-loop system asymptotically track a specified bounded signal (i.e., $\lim_{k \rightarrow \infty} |y(k) - w(k)| = 0$, where $w(k)$ is a specified bounded signal).

The stability and convergence of the system are analyzed by considering condition 1 and (15) and (22), it can be obtained that

$$|v[u(k), \bar{x}(k)]| \leq |v_1(k)| + |v_2(k)| \cdot |\Delta u(k)| \leq \varepsilon_1 [1 + |\Delta u(k)|] \cdot \|[u(k-1), \bar{x}(k)]\| + \varepsilon_2 [1 + |\Delta u(k)|]$$

$$\leq \varepsilon_3 \|[u(k-1), \bar{x}(k)]\| + \varepsilon_4$$

$$\text{Where } \varepsilon_3 = \varepsilon_1 [1 + |\Delta u(k)|] \text{ and } \varepsilon_4 = \varepsilon_2 [1 + |\Delta u(k)|].$$

Therefore, the unmodeled dynamics $v[x(k)]$ satisfies the following condition :

$$\text{Condition 2 } |v[x(k)]| \leq \gamma(k), \forall k$$

Where $\gamma(k) = \varepsilon_3 \|[u(k-1), \bar{x}(k)]\| + \varepsilon_4$ and ε_3 and ε_4 are constants which satisfy $0 \leq \varepsilon_3 < 1, \varepsilon_4 \geq 0$.

RESULTS:

The Discrete-time nonlinear system which is used for the estimation is represented by

$$y(k+1) = 2.6y(k) - 1.2y(k-1) + u(k) + 1.2u(k-1) - \frac{u(k) + u(k-1) + y(k) + y(k-1)}{1 + u(k)^2 + u(k-1)^2 + y(k)^2 + y(k-1)^2}$$

The estimation of unmodeled dynamics is done by replacing the unknown control input $u(k)$ by historical data $u(k-1)$ and it is given by

$$v[x(k)] = \sin[u(k) + u(k-1) + y(k) + y(k-1)] - \frac{1}{1 + \dots}$$

$$\text{Where } x(k) = [u(k), u(k-1), y(k), y(k-1)]^T$$

At first the estimation is done by using a Two layer Back Propagation Neural Network, in which 18 nodes are taken in the hidden layer whose activation function is of the S-transfer function and learning rate is set to $l_r = 1$ momentum factor $mc = 0.95$, training time is selected as 300. Second, the estimation is done by ANFIS by considering

$$\bar{x}(k) = [u(k-1), y(k), y(k-1)]^T$$

$$\Delta u(k) = u(k) - u(k-1)$$

From (10) and (13) taking the unmodeled dynamics $v[x(k)]$ around $u(k)=u(k-1)$

and using the total differential formulas $v[x(k)]$ can be written as

$$v[u(k), \bar{x}(k)] \approx v_1(k) + v_2(k) \cdot \Delta u(k)$$

The input data $u(k-1), u(k-1), y(k)$ and $y(k-1)$ are transformed into $\hat{u}(k-1), \hat{u}(k-1), \hat{y}(k)$ and $\hat{y}(k-1)$ by using "one to one mapping α ". The membership functions of ANFIS are Gaussian type with three fuzzy sets for each input and training time is set to 40, and $\epsilon_1 = 10^{-6}$ and $\epsilon_2 = 10^{-5}$ and the estimation is calculated by (3.3) and the simulated results are

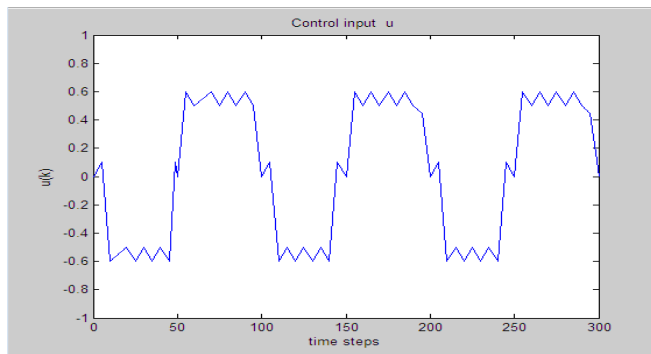

Fig4:Control Input

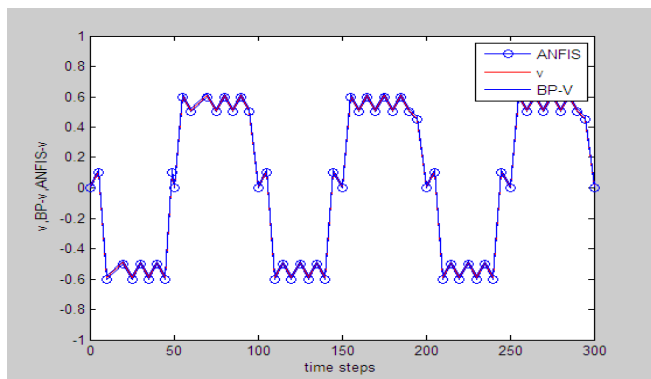

Fig 5: True value of the unmodeled dynamics and its estimation value obtained by BP NNs and the ANFIS

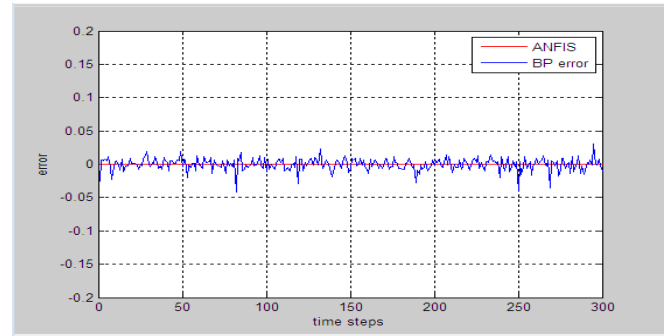

Fig 6. Estimation Error

Fig 5. shows the estimated value of unmodeled dynamics fits quite well with its true value with a very small estimation error, while a slightly big estimation error is produced by BPNN. The estimation precision is explained in terms of upper bound error, Mean Square Error(MSE) are listed in Table 1, and the MSE is calculated by using the formula

$$MSE = \sqrt{\frac{1}{n} \sum_{k=1}^n (v_{app}[x(k)] - \bar{v}(x(k)))^2}$$

Where $v_{app}[x(k)]$ denotes the approximate value of the different methods and $\bar{v}(x(k))$ denotes the mean value of unmodeled dynamics.

Table 1: Comparison Of the Two kinds Of the Processing Methods:

Network Types	BP NN	ANFIS
Upper bound of error	0.2663	0.2026
MSE	0.0026	2.9494e-004
Coefficient	0.9967	0.9995

Therefore, the estimation value which is obtained is very close to the real value of unmodeled dynamics. Simulation Experiment for the Three methods of processing unmodeled dynamics: The Three different methods that are used to deal with the unmodeled dynamics of the system are

1. The First method is estimating the unmodeled dynamics using ANFIS.
2. The Second method is replacing $u(k)$ with $u(k-1)$
3. The Third method uses the value of unmodeled dynamics $v[x(k-1)]$ to replace $v[x(k)]$.

The following nonlinear system is considered for the unmodeled dynamics $v[x(k)]$

$$y(k+1) = \frac{2.6y(k) - 1.2y(k-1) + u(k) + 1.2u(k-1) + \sin[u(k) + u(k-1) + y(k) + y(k-1)]}{1 + u(k)^2 + u(k-1)^2 + y(k)^2 + y(k-1)^2}$$

The origin is the equilibrium point of the system

$$A(z^{-1}) = 1 - 0.6z^{-1} + 0.2z^{-2}$$

$$B(z^{-1}) = 1 + 0.5z^{-1} \quad n_a = 2, n_b = 1$$

and unmodeled dynamics is given by

$$v[x(k)] = \sin[u(k) + u(k-1) + y(k) + y(k-1)] - \frac{u(k) - u(k-1) + y(k) + y(k-1)}{1 + u(k)^2 + u(k-1)^2 + y(k)^2 + y(k-1)^2}$$

the control signal which varies between -1 and 1 is applied to the nonlinear system, that is

$$u(k) = \sin\left(\frac{2\pi k}{50}\right)$$

and the initial states are $y(0)=0, u(0)=0$

The simulation results are obtained as follows:

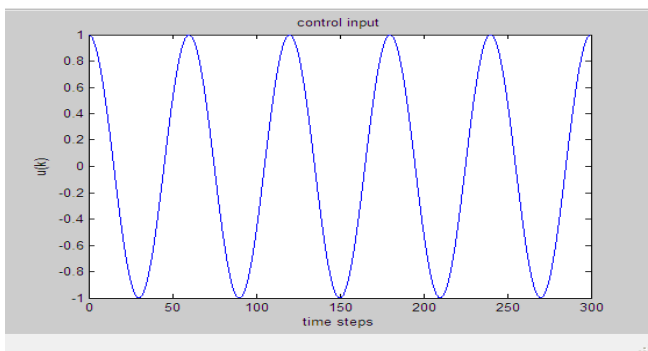

Fig 7: Response of Control input u.

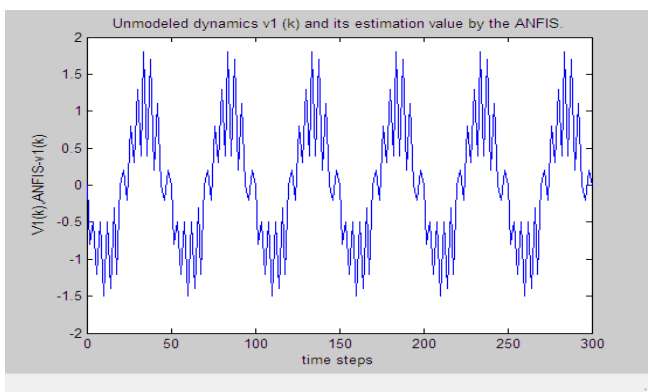

Fig 8: Unmodeled dynamics $v_1(k)$ and its estimation value by the ANFIS

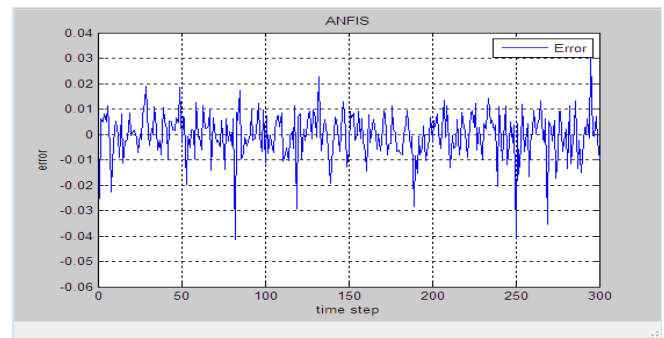

Fig 9: Error of $v_1(k)$

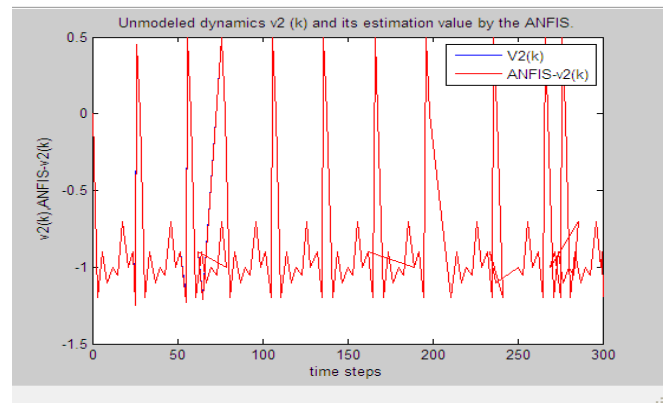

Fig 10: Unmodeled dynamics $v_2(k)$ and its estimation value by the ANFIS

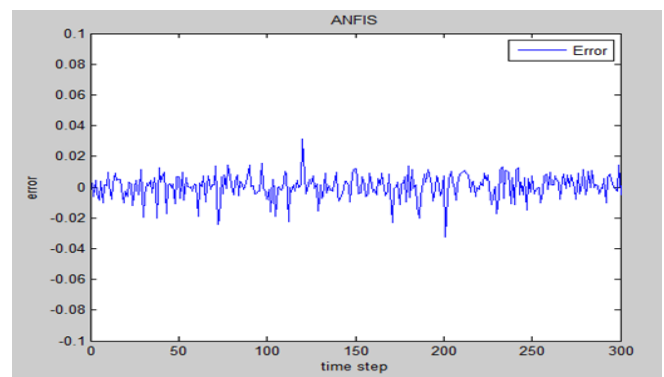

Fig 11: Error of $v_2(k)$

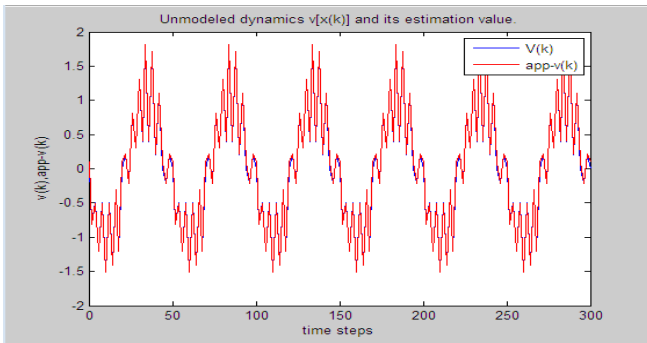

Fig 12: Unmodeled dynamics $v[x(k)]$ and its estimation value.

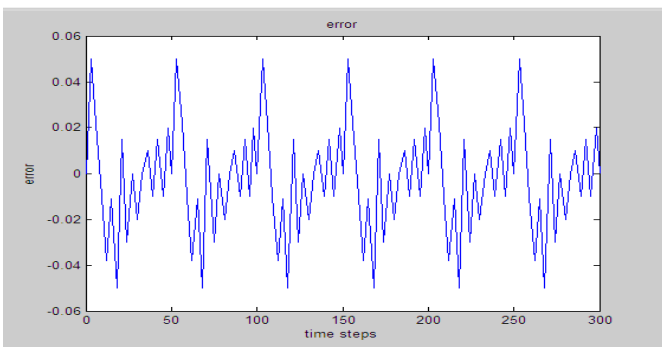

Fig13: Error

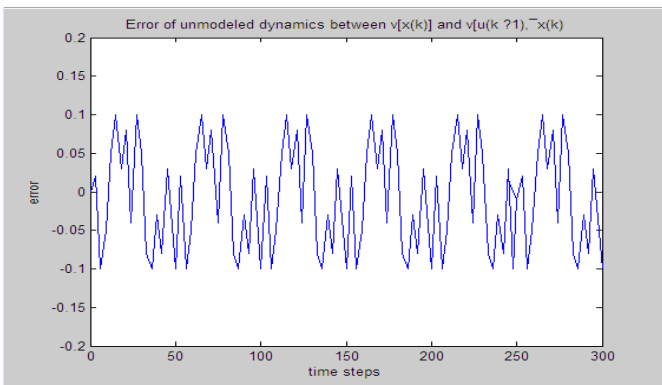

Fig14: Error of unmodeled dynamics between $v[x(k)]$ and $v[u(k-1), \bar{x}(k)]$

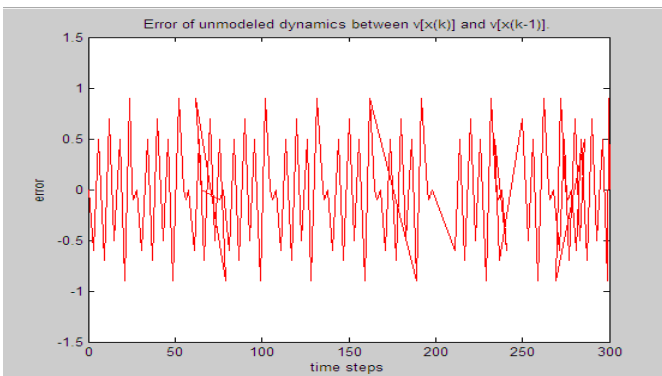

Fig 15: Error of unmodeled dynamics between $v[x(k)]$ and $v[x(k-1)]$

From Fig15 and 16, it is observed that error is very small using the ANFIS method and its values are distributed near zero, while the error produced by the second method is large and the error by third method is even larger.

The precision of the three methods is compared by using upper bound error, MSE and correlation coefficients and are given in Table 2

Table 2: Upper bound error, MSE and correlation coefficients of Three Methods

Method	First	Second	Third
Upper Bound Error	0.0533	0.110	1.1793
MSE	31687e-004	0.0031	0.3296
Correlation coefficient	0.9997	0.9975	0.735

From Table 2, the value produced by the first method is almost close to 1, which means that the estimated dynamics is very close to the true value of unmodeled dynamics.

APPLICATION IN CONTROL:

The improved estimation algorithm that is based on the ANFIS for the unmodeled dynamics is combined with the control algorithm to verify the effectiveness of the method used.

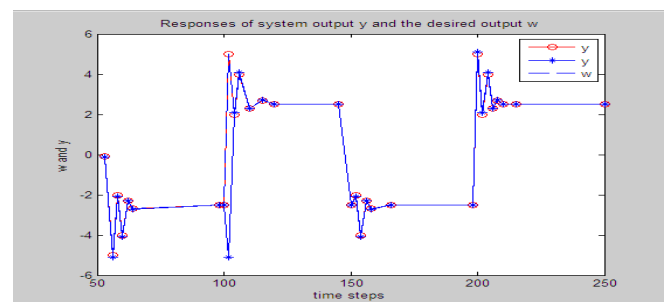

Fig 16: Responses of system output y and the desired output w when the switching control is used.

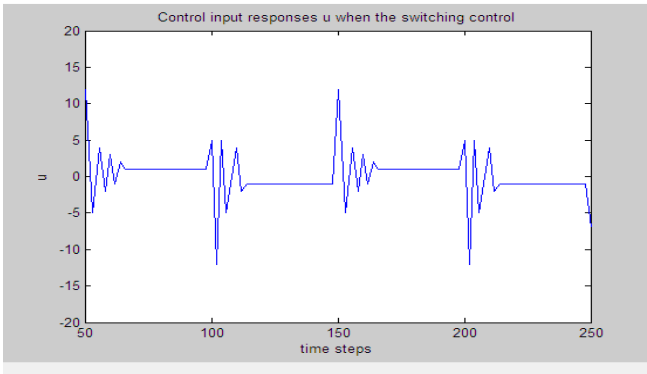

Fig 17: Control input responses u when the switching control is used

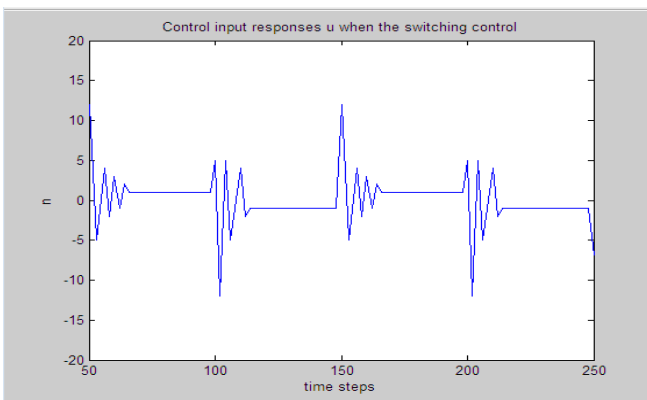

Fig 18: Control input responses u when the switching control is used.

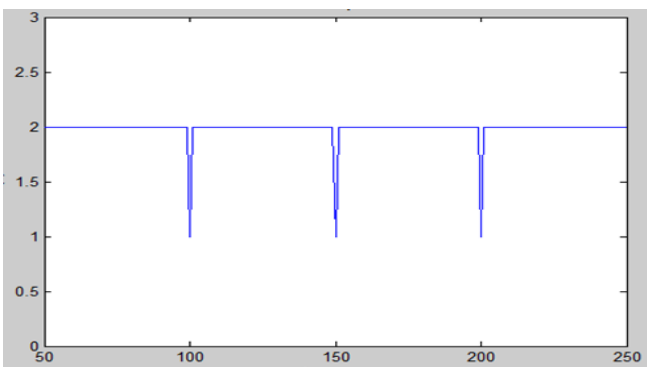

Fig 19: Switching Sequence.

CONCLUSION:

An estimation algorithm that is based on an improved ANFIS for unmodeled dynamics has been presented for a class of complex industrial systems, where the unmodeled dynamics cannot be ignored. It has been shown that the proposed algorithm overcomes the problem that the unknown control input is embedded in unmodeled dynamics so that the controller and the true value of unmodeled dynamics are both difficult to obtain.

Moreover, it has been shown that the proposed method improves the estimation precision of the unmodeled dynamics and simplifies the controller design simultaneously. Finally, the method is used in a nonlinear switching control. Simulation results have confirmed that the nonlinear adaptive switching control adopting the proposed estimation method can give desired dynamic performance for the closed-loop system.

REFERENCES:

1. T. Y. Chai, L. F. Zhai, and H. Yue, "Multiple models and neural networks based decoupling control of ball mill coal-pulverizing systems," *J. Process Control*, vol. 21, no. 3, pp. 351-366, Mar. 2011.
2. T.Y. Chai, Y.J. Zhang, H. Wang, C. Y. Su, and J. Sun , "Data based virtual unmodeled dynamics driven multivariable nonlinear adaptive switching control," *IEEE Trans. Neural netw.*, vol.22, no.12, pp.2154-2172,Dec.2011
3. K.Y.Zhu, X.F.Qin, and T.Y.Chai, "A new decoupling design of selftuning multivariable generalized predictive control," *Int J. Adapt Control Signal Process*,vol.13,n.13,pp.183-196,May 1999.
4. Y.Fu and T.Y.Chai, "Nonlinear multivariable adaptive control using multivariable models and neuralnetworks,"*Automatica*,vol.43,no.6,pp.1101-1110,Jun2007.
5. Y.J. Zhang, T.Y Chai, and H.Wang , "A nonlinear control method based on ANFIS and multiple models for a class of nonlinear systems and its application," *IEEE Trans, Neural Netw.*,vol.22, no.11,pp.1783-1795,Nov.2011