

## A NEW SECURE CHAOTIC COMMUNICATION SYSTEM

Goutam Kumar<sup>1</sup>, Prof. Ashish Suryawansi<sup>2</sup>

<sup>1</sup>KNP Engineering Institute

Email: goutamec@gmail.com

<sup>2</sup> KNP Engineering Institute

Email: ashish.suryawansi27@gmail.com

\*\*\*

**Abstract-** In this paper, a new chaotic communication system has been implemented using ORCAD software. The basic idea behind this communication system is to provide a secure communication through wireless channel using the nonlinear dynamics of the chaotic circuits. The nonlinearity of the chaotic circuit is used to provide a hardware encryption for the analog and digital signals. After the encryption, the signal will resemble as noise and the message would easily be transmitted through wireless channels without coming into the eye of the hackers.

**Keyword-**Chaos, compression, simultaneous compression and encryption.

### INTRODUCTION

Pecora and Carrol published their results on chaos synchronization [1-3] which says that “Although the motions of independent chaotic systems are uncorrelated with each other, it is possible under some conditions to synchronize a subsystem of one chaotic system with a separate chaotic system by sending a signal from the chaotic system to the subsystem” These growing of literature supports the possibility of practical communication using chaotic signals. For example, Murali et al. proposed a spread-spectrum communication system based on chaotic masking [4] “Design of Noncoherent Receiver for Analog Spread-Spectrum Communication Based on Chaotic Masking”. Rulkov et al. reported a “Digital Communication Using Chaotic-Pulse-Position Modulation” method [5]. Callegari et al. designed successful experiment “Chaos-Based FM Signals: Application and Implementation Issues” [6]. Schweizer et al. demonstrate a chaotic communication code “Symbolic Dynamics for Processing Chaotic Signals—II: Communication and Coding” [7].

One of the recent developments of the nonlinear dynamics and chaos was the realization of a method which can be used in cryptography. This method is known as chaos synchronization. The chaos synchronization is a method in which the two identical (they can't be perfectly identical) chaotic systems generate a same signal. This can be used in the private communications, what is shown after a synchronization proof. Here the basic facts and things about the cryptography are explained. It can be something like

knowing what is a cipher, a secret key, a public key and related things. This is mainly for better understanding of the affiliation with the chaos synchronization. Also there is one more thing important here. At the time of analysis the transmitted message is taken in the form of triangular wave, square wave and sinusoidal signal. Let's take a message which we want to be sent. The message will be first masked by the chaotic signal. Masking can be done by adding the two signals. Now, the receiver will hear only the chaotic mask what isn't useful information. What the receiver needs is to obtain a same chaotic mask. The received message is then subtracted from the mask what gives the original message or useful information.

### BASIC ELEMENTS FOR SECURE CHAOTIC COMMUNICATION SYSTEM

Basic elements for secure chaotic communication system are Chaos, Chaotic Signals, Chaotic oscillator, Attractor, Chaotic Masking Circuit, Nonlinear Filter, Chaotic Synchronization, and Encryption/Decryption.

Chaos is one of the most interesting recent developments in the area of system dynamics. In the past it was generally assumed that a system must follow either purely deterministic or purely probabilistic laws. In some cases one could imagine a simultaneous superposition of both sets of laws, but as a rule they would be clearly identifiable as separate entities. This attitude proved to be too narrow when applied to nonlinear systems where a middle course is possible, the system following strict deterministic laws which nevertheless lead to a seemingly chaotic behavior over some well defined ranges of parameters. At first such a situation appeared to be very odd, not to say contradictory, but its existence is now firmly established both on theoretical and experimental grounds.[3,4]

Chaotic signals are non-periodic, random-like and bounded signals that are generated in a deterministic manner

[Alligood *et al.*, 1997; Brown, 1996; Elaydi, 2000; Hilborn, 2000]. Chaotic systems, i.e., systems that produce chaotic signals, form a special category in deterministic dynamical systems. The chaotic dynamical systems can be broadly classified into continuous-time and discrete-time types. In a continuous-time system, the chaotic signal is derived from a set of differential equations, i.e.

$$g(x, t) = \dot{x}, \quad x(t_0 = x_0)$$

Where  $x$  is a vector representing the state of the system at time  $t$  and  $g$  denotes the set of differential equations governing the dynamical system. In a discrete time chaotic system, the chaotic sample at the  $k$ <sup>th</sup> iteration is generated from a set of difference equations, i.e.

$$x_k = g(x_{k-1}) = g^{(k)}(x_0)$$

Where  $x$  is the state vector and  $g(\cdot)$  denotes the iterative function, which is usually called a *chaotic map*. Figure 1 plots a chaotic signal, generated by a one dimensional chaotic map, against normalized time. It can be observed that the signal never repeats itself, looks random-like and is bounded in the interval  $[-1,+1]$ .

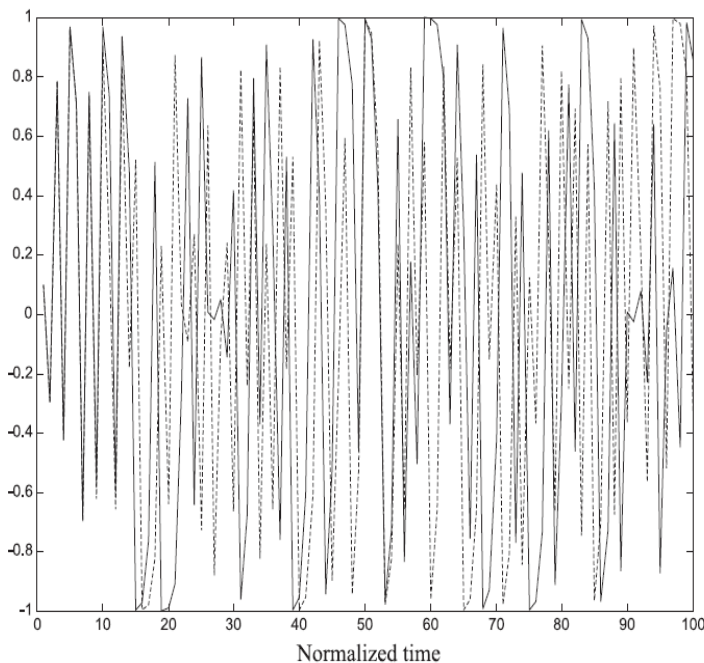

**Fig 1-Two chaotic signals from a chaotic generator with different initial conditions**

Oscillators are the electronics circuit that generates periodic waveforms. Oscillators are of different types such as

multivibrators, sinusoidal oscillators, triangular wave generators, pulse generators etc.

Chaotic oscillators are the oscillators that produce non-periodic, nonlinear oscillations. These non-periodic signals initially treated as noise till 1960's and is only studied under nonlinear dynamics in mathematics. But latter in 1980's, the electrical engineers first time "officially" announced the existence of chaos in electrical systems. Since the noise-like behaviors of chaotic electronic circuits, electrical engineers felt uncomfortable to deal with them. It was physicists first showed in 1990 that chaos could be controlled

## SECURE CHAOTIC COMMUNICATION SYSTEM

### Chua's Circuit

A chaotic attractor has been observed with an extremely simple autonomous circuit.

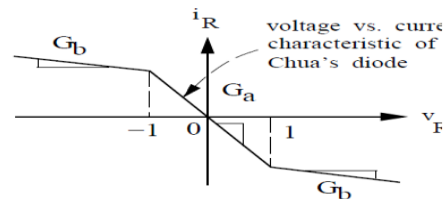

Fig 2-A Chua's Oscillator

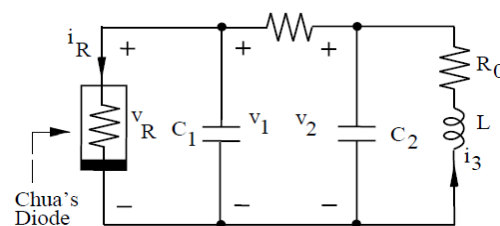

Fig 3-Characteristic for nonlinear diode of Chua's circuit

This circuit contains four linear elements and a nonlinear resistor, called Chua's diode. The existence of chaotic attractors from the Chua circuit had been confirmed numerically. This chaotic circuit was designed using a systematic nonlinear circuit synthesis technique [5]

The state equations for the Chua's oscillator are given by

$$\frac{dv_1}{dt} = \frac{1}{C_1} [G(v_2 - v_1) - f(v_1)]$$

$$\frac{dv_2}{dt} = \frac{1}{C_2} [G(v_2 - v_1) + i_3]$$

$$\frac{di_3}{dt} = \frac{1}{L} [-v_2 - R_0 i_3]$$

Where  $v_1$ ,  $v_2$  and  $i_3$  are the voltage across  $C_1$ , the voltage across  $C_2$  and the current through  $L$ , respectively. We set  $G = 1/R$ . The term  $R_0 i_3$  is added to account for the small resistance of the inductor in the physical circuit. The piecewise linear v-i characteristic  $f(v_1)$  of the Chua's diode, is given by

$$f(v_1) = G_b v_1 + \frac{1}{2} (G_a - G_b) (|v_1 + E| - |v_1 - E|)$$

where  $E$  is the breakpoint voltage of the Chua's diode as shown in Fig.3.

### Transmitter and Receiver of communication system

For the analysis performance of the system, ORCAD software from P-Spice version 7.2 is taken, the communication system is designed using the appropriate components. This transmitter circuit consists of a Chua's circuit for the generation of chaotic signals and few OP-Amps are used to design adder and masking circuit.

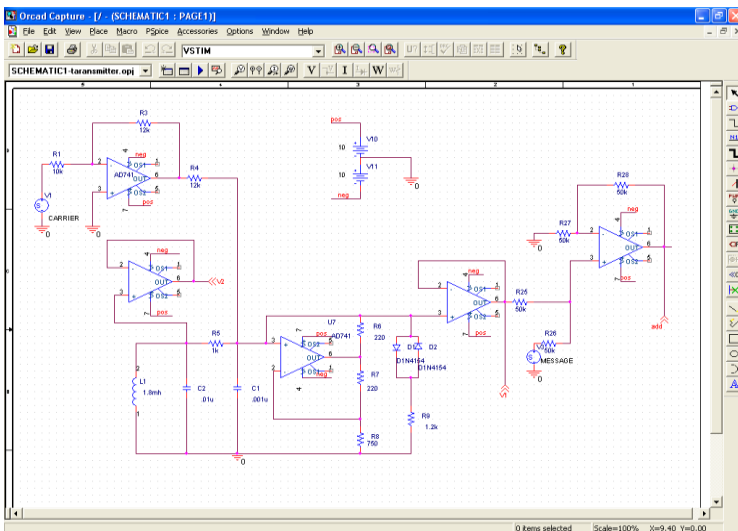

Fig.4 Transmitter drawn on ORCAD

The receiver of the communication system consists of a synchronous sub-system from the transmitter which synchronizes the receiver from the transmitter to retrieve the message signal.

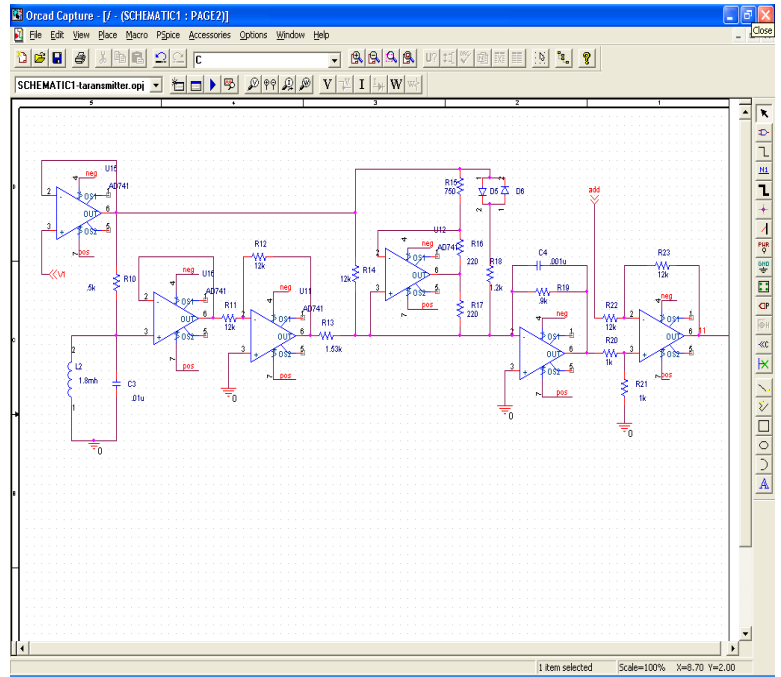

Fig.5 Receiver drawn on ORCAD

### Synchronization of the Receiver sub system

Chaos is sometimes described as a situation in which a system gets out of synchronization with itself [8], resulting in a complex non-periodic motion. If two independent chaotic systems are started with the same initial conditions, any arbitrarily small difference in these conditions will grow exponentially in time [9]. After some time; the motion of the two systems will be uncorrelated.

For example, Fig.6 shows a plot of a voltage from a chaotic circuit versus a voltage from the same point in another identical but independent circuit. The trajectory is traced randomly over the screen, whereas if the circuits were synchronized, the trace would be a straight 45 degree line.

It is, however, possible to have two nonlinear systems synchronized, despite their chaotic motion, provided they are both driven with the proper signal. We have devised a way to drive a subsystem of a chaotic system with a signal from a similar chaotic system so that corresponding signals from the two subsystems are identical. We have built a simple circuit based on chaotic

circuits described by Newcomb. We use this circuit to demonstrate this chaotic synchronization.

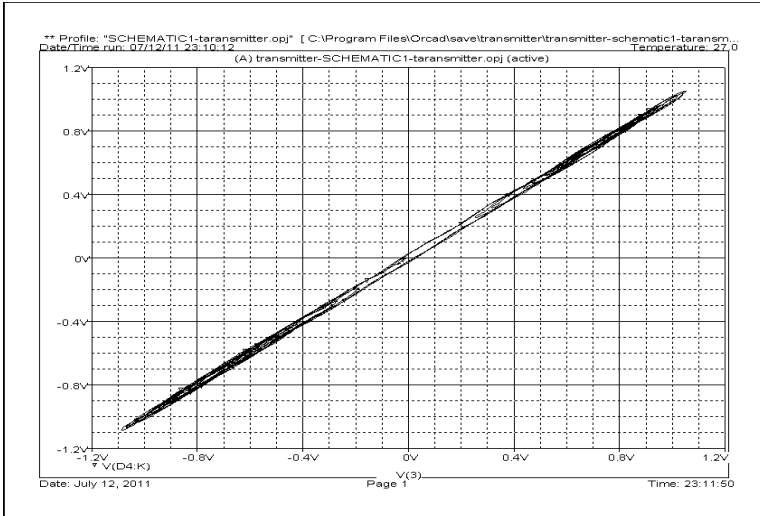

Fig 6-graph between voltage VC1 and VC2

#### IV. ORCAD SIMULATION AND RESULTS

Circuit for the transmitter and the receiver is simulated on ORCAD software version v9.2. Circuit for the transmitter and receiver is shown in figure 4 and figure 5. It consists of a Chua's circuit and a masking circuit and a pair of voltage follower. The power supply for the operational amplifier AD 741 is given through 2 dc battery of 10 volts each. The component name and its specifications are given along with the diagram. The performance of the communication system is analyzed by the ORCAD software and its window for simulation is shown along with the transmitter circuit diagram.

The graph shown below is the chaotic signal produces at the capacitor C1 of the Chua's circuit. This is the signal that will further mask the message signal.

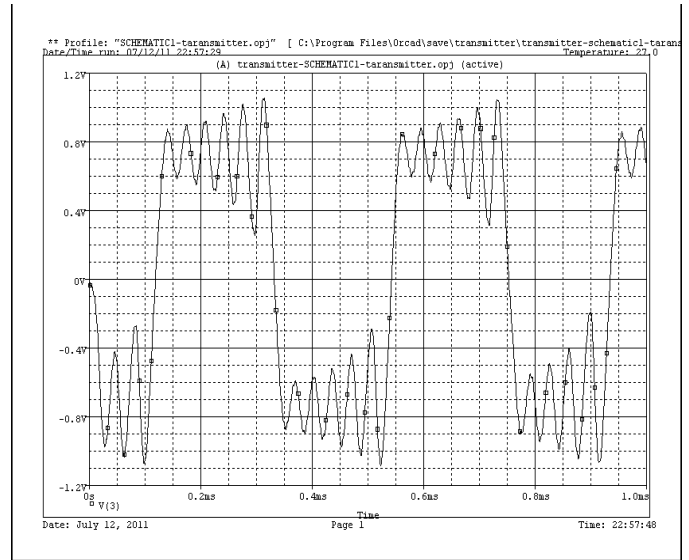

Fig 7-Voltage at the capacitor C1 of the transmitter

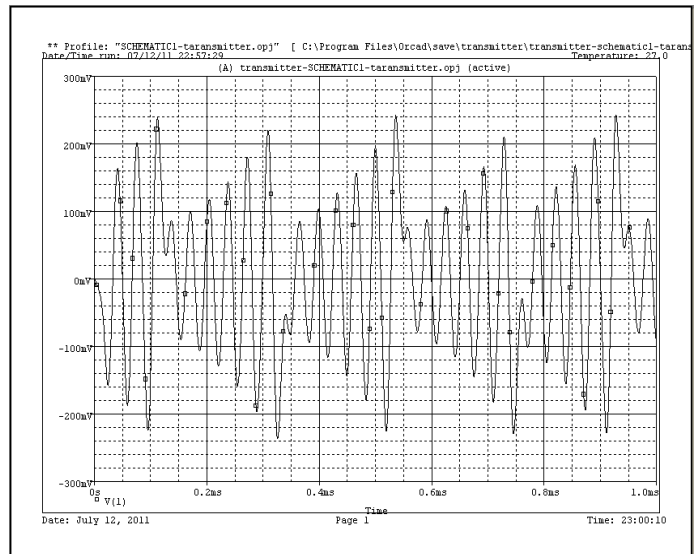

Fig 8-Voltage at the capacitor C2 of the transmitter

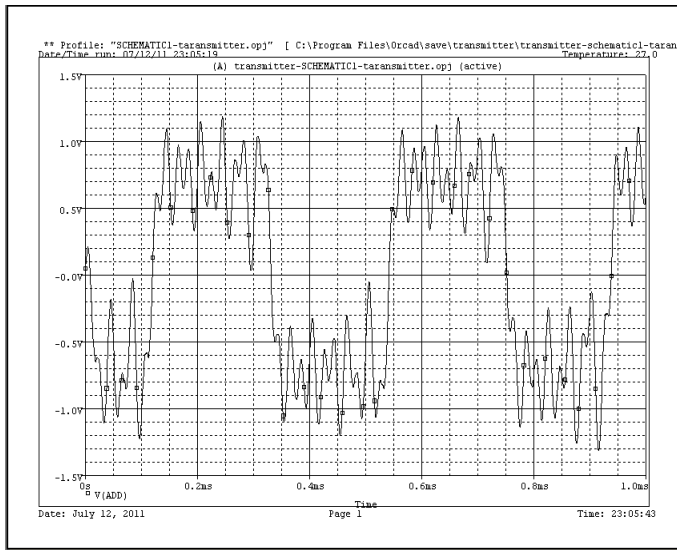

Fig 9-Graph of the transmitted signal

This is the combined graph of the sinusoidal message signal that we have transmitted through our chaotic transmitter and of the sinusoidal message that we have received at the receiver. The completely overlapping of the signals shows that the signal that we have received at the receiver is exactly same as the message we have transmitted at the transmitter

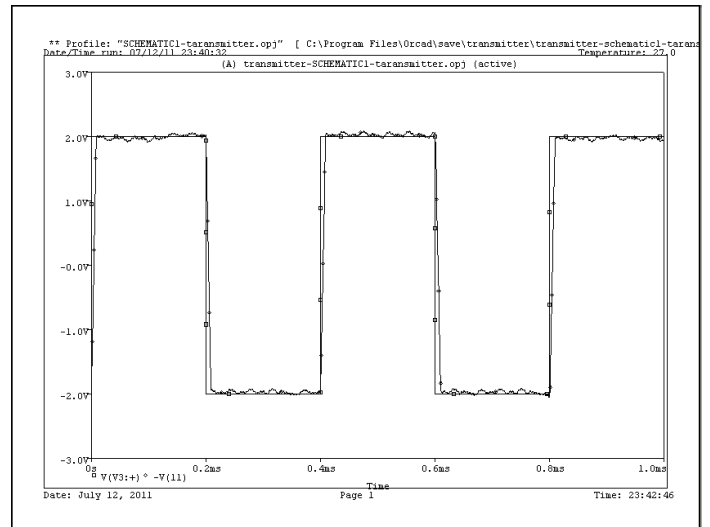

Fig 11-Square wave as the transmitted and received signal

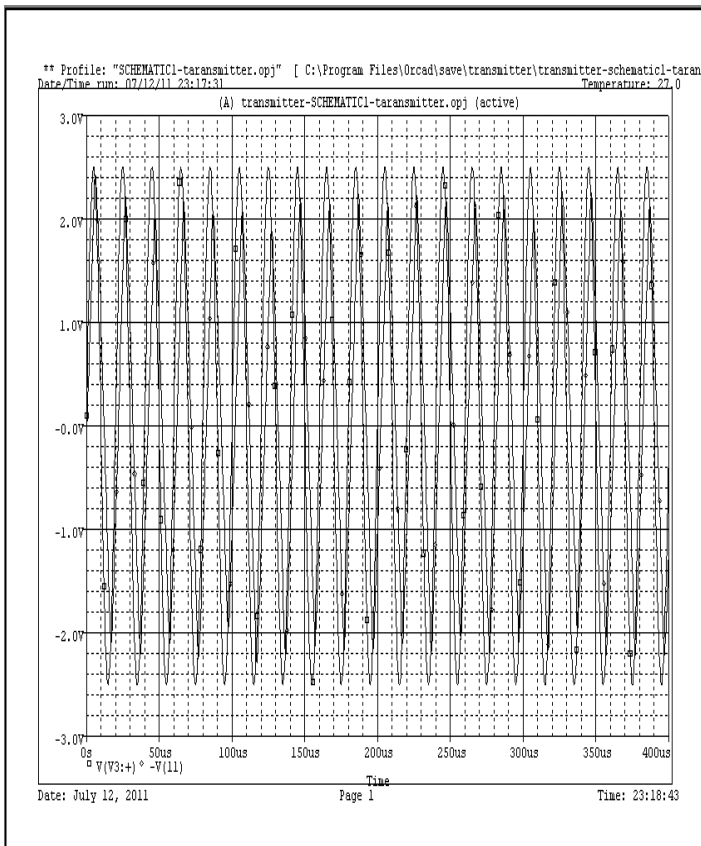

Fig.10 Sinusoidal signal as transmitted and received signal

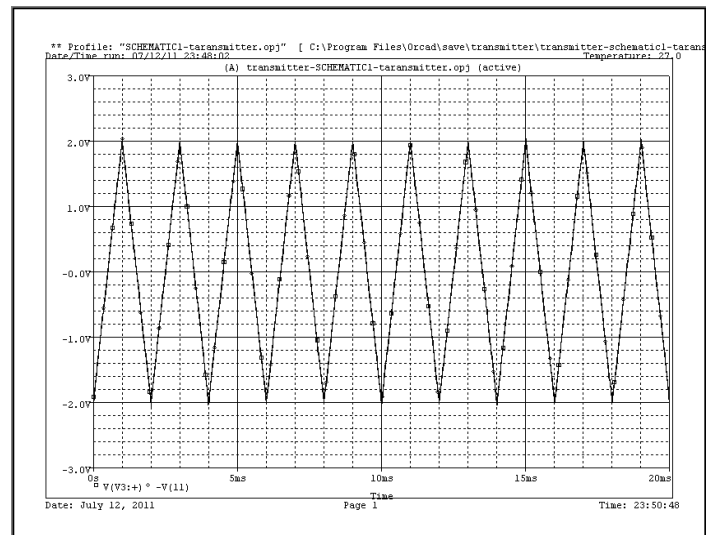

Fig 12-Triangular wave as transmitted and received signal

## CONCLUSION

In the dissertation, it has been concluded by simulation that this secure chaotic communication system has shown better results. This circuit have also provided hardware encryption key using chaotic oscillator circuits for encryption of message signal. This circuit has produced outstanding results for different (square, triangular and sinusoidal) signals and is very effective for data communication through wireless communication. Simulation results validate the new chaos-based secure communication method.

Several perspective investigations can be performed in the future:

- The analog chaotic signal which is used as the encryption key can be digitalized
- Some different modulation schemes could be introduced in chaotic modulation scheme which could show more better results.

## REFERENCES

1. L.M. Pecora and T.L. Carroll, "Synchronization in chaotic system," *Phys. Rev. Lett.*, Vol., pp. 821-824, Feb. 1990
2. T.L. Carroll and L.M. Pecora, "Synchronization chaotic circuits," *IEEE Trans. Circuits. Sys.*, vol 38, pp.453-456 Apr. 1991
3. L.M. Pecora and T.L. Carroll, "Driving systems with chaotic signals," *Phys. Rev. A.*, vol. 44, pp. 2374-2383 Aug. 1991
4. K Murali, H. Leung, and H. Yu, "Design of Noncoherent Receiver for Analog Spread-Spectrum Communication Based on Chaotic Masking," *IEEE Trans. Circuits Syst. I*, vol. 50, pp. 432-441, Dec. 2003
5. N.F. Rulkov, M.M. Sushchik, L.S. Tsimring, and A.R. Volkovskii, "Digital Communication Using Cgaotic-pulse-Position Modulation," *IEEE Trans. Circuits Syst. I*, Vol. 48, Apr.pp.1436-1445,20001.
6. S.Callegari, R. Rovatti, and G.Setti, "Chaos - Based FM Signals: Application and Implementation Issues," *IEEE Trans. Circuits Syst. I*, vol.50, Mar.pp. 1141-1147, 2003.
7. J.Schweizer, and T. Schimming, "Symbolic Dynamics for Processing Chaotic Signals-II: Communications and Coding," *IEEE Trans. Circuits Syst. I*, Vol.48,july,pp.1283-1294, 2001.
8. N.J. Corron,and D.Hahs,"A New Approach to Communication Using Chaotic Signals," *IEEE Trans. Circuits Syst. I*, Vol.44, Feb.pp. 373-382, 1997.
9. Y. S. Tang, Alistair I. Mees, and Leon O. Chua, "Synchronization and chaos," *IEEE Trans. Circuits Syst.*, vol. CAS-30, pp. 620-626,Sept. 1983.
10. Thomas S. Parker and Leon O. Chua, "Chaos, a tutorial for engineers," *Proc. IEEE*, vol. 75, pp. 982-1008, Aug. 1987.
11. Louis M. Pecora and Thomas L. Carroll, "Synchronization of chaotic systems," *Phys. Rev. Lett.*, vol. 64, Feb. 1990.