

Hybrid PI controller design and hedge algebras for control problem of dissolved oxygen in the wastewater treatment system using activated sludge method

Fei Luo ¹, Binh Lam Hoang ¹, Duy Nguyen Tien ², Phuong Huy Nguyen ²

¹ School of Automation Science and Engineering, South China University of Technology (SCUT), GuangDong, GuangZhou, China

² Faculty of Electronics, Thai Nguyen University of Technology (TNUT), Thai Nguyen, Vietnam

Abstract - This paper presents the design method of the controller by crossing between classic PI controller and the one using the hedge algebras to enhance the operational quality of the system. The results are assessed and verified through simulation for control problems of dissolved oxygen in the wastewater treatment system using activated sludge method.

Key Words: Hybrid controller, hedge algebra, control the dissolved oxygen, wastewater treatment using activated sludge method.

1. INTRODUCTION

Waste water treatment is a large, complex and nonlinear system due to being influenced by big speed, pollution as well as the uncertainty related to the composition of the input waste stream. In reality, these systems are always required to operate continuously and stably so that the natural environment is able to absorb the treated waste water safely. Therefore, the size as well as operation quality of the wastewater treatment plants is rapidly increasing.

The majority of advanced wastewater treatment systems apply the process using activated sludge treatment. According to this method, the natural microorganisms are facilitated to develop in the optimized conditions of the consumption of biodegradation organic matter in wastewater influent [1]. This process is multivariate in nature. However, if the time scale is considered, the operation of the oxygen will take a few minutes while the substrates and other components will develop within hours. Thus, we can separate the control problems into two different classes, separate feedback control loop of dissolved oxygen (DO) from the other control problems. In fact, as the level of DO in aerobic reactors has significant influence on the behavior and activity of heterotrophic microorganisms and autotrophic ones living in activated

sludge, it is DO control problem that is the most commonly considered and solved in this field [5].

In the past, most of the DO controllers were recommended to use classical PI controller due to its advantages in the simple design, universal properties, and most controllers were required to meet economic targets. Recently, the modern controller such as intelligent controllers based on fuzzy logic (FLC), the hybrid between FLC and PI has also been proposed with the aim of optimizing the efficiency [7], [9].

Hedge algebras is an approach that is equivalent with fuzzy logic. In some practical problems, the quality of the controllers which uses hedge algebras even brings better results due to its advantages in ensuring the ordering relationship between the linguistic values appeared in the rule system of inference [2].

In this paper, the authors present an approach using the hybrid controller between HAC and PI for the control problem DO. Parameters of the controllers are optimized using genetic algorithms (GA). Therefore, it is completely possible to compare the quality of the hybrid controller with the classical PI controller through simulation.

2. DO control problem in the wastewater treatment system based on activated sludge method

As can be seen in Figure 1, the process of wastewater treatment based on activated sludge method is described. First, the flow of input wastewater is processed in the biological reactor. At this position, due to the influence of microorganisms, the substrate was minimized. After that, the water is drained to a settling tank, where sludge biomass is restored. Fresh water at the top of the clarification tank is removed from the system, a small part of the sludge is put back as the input of the bioreactor to maintain the biomass at a proper level, allowing the decreasing of organic substances in wastewater. The rest of the sludge is purged out [9].

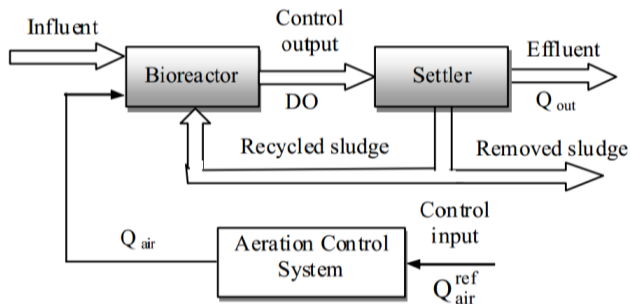

Fig -1: Overview of the wastewater treatment process using activated sludge [7]

As can be seen in Figure 1, the process of wastewater treatment based on activated sludge method is described. First, the flow of input wastewater is processed in the biological reactor. At this position, due to the influence of microorganisms, the substrate was minimized. After that, the water is drained to a settling tank, where sludge biomass is restored. Fresh water at the top of the

clarification tank is removed from the system, a small part of the sludge is put back as the input of the bioreactor to maintain the biomass at a proper level, allowing the decreasing of organic substances in wastewater. The rest of the sludge is purged out [9].

In biological reactor, aeration is an important part as aerobic condition will favor the development of a variety of microorganisms, including heterotrophic bacteria, thereby it contributes to remove substrate in wastewater. For example, nitrate bacteria oxidize ammonia into nitrates. The powerful and rapid influence of aerobic conditions to the growth of the biomass makes the control DO become a difficult and essential task of the process of biological wastewater treatment based on activated sludge method. Insufficient oxygen or excess in the aeration tank leads to the deterioration of the activated sludge. Therefore, it is the issues of control DO that are best studied in wastewater treatment.

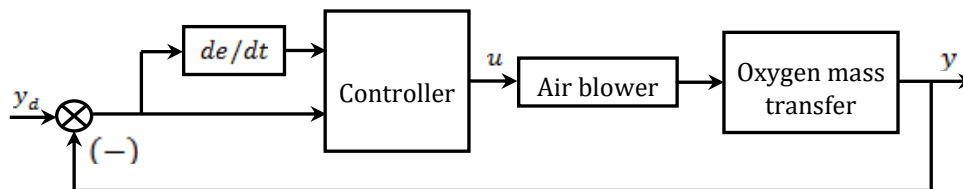

Fig -2: Block diagram of the controller DO

In figure 2, a block diagram of the controller DO is shown in which different approaches in building controllers may be used depending on the design criteria such as classical PI controller, a fuzzy controller, PID hybrid fuzzy controller [7] and the hybrid controller HAC-PI as in this paper.

3. Define parameters of the DO controller using genetic algorithms

Genetic Algorithm (GA) is a method of global random search simulating natural evolution. The genetic algorithms begin in an unknowledgeable way of the exact

solution and it completely depends on the response from the environment by exploring the evolution (ie breeding, hybridization and mutation) to draw out the best solution. By starting at some independent points and parallel search, GA is able to avoid local extreme and convergence to sub-optimal solutions. Thus, GA has been proved to have the ability to locate high-performance area in the complex space without encountering the difficulties related to the dimensionality of space as the gradient techniques or the best searching methods based on partial information.

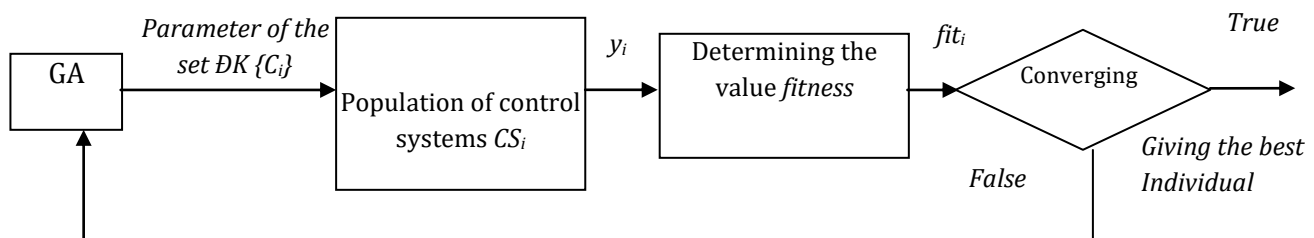

Fig -3: Optimizing parameters using GA

A genetic algorithm is usually initialized with a random population ranging from 20-100 individuals. Each individual is often represented by a series of real numbers or binary called chromosomes. The effective evaluation of a chromosome is measured by the objective function. It assigned each chromosome a corresponding number called the value fitness. In this way, fitness of each chromosome is computed, algorithms identify the most appropriate chromosome and they are applicable (breeding, hybridization and mutation).

We can see in Figure 3 that the use of GA to find the appropriate parameters for the controller is shown. Each chromosome $\{Ci\}$ will represent the parameters of a controller $\{CSi\}$. Adaptability of each chromosome will be evaluated by function fitness gives the value fit_i . The individual CSi is considered the most adaptable if fit_i is the smallest. When convergence conditions warrant, we will find the chromosome containing the most relevant parameters of the controller. Here, adaptive function is calculated as the followings:

$$fit_i(k) = \sqrt{\sum_{j=1}^M (e_j(k))^2} \tag{1}$$

Where: $e(k)$ is the discrepancy between the theoretical output and actual output; M is the number of samples to examine.

4. Classic PI controller for the problem DO

Classic PI controller is described as follows:

$$u(t) = K_p e(t) + \frac{K_p}{T_i} \int_0^t e(t) dt \tag{2}$$

Where: $e(t)$ is the deviation of the control signal and $u(t)$ is the control signal at the output of the controller.

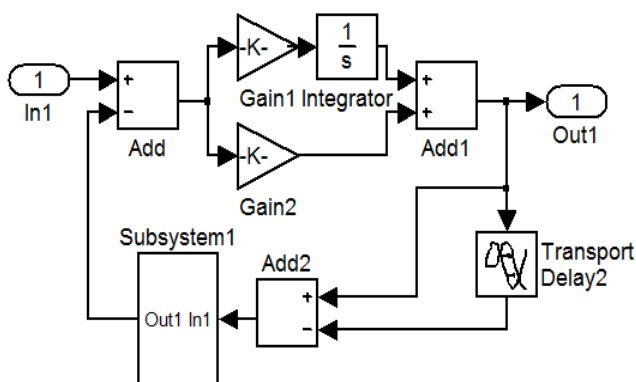

Fig -4: Simulating diagram of PI controller

It can be seen from the figure 4, simulating diagram of PI controller is illustrated. This controller gives the control value $u(t)$ at the output which makes control deviation $e(t)$ decrease to 0. According to (2), the coefficients (KI and TI) are scale factor and time constant of the controller. These parameters can be calculated and optimized. In this paper,

the parameters are determined by GA algorithm as described in Part 3.

5. The hybrid controller HAC-PI

The hybrid PI controller is built by combining the output of the controller HA and a conventional PI controller. This structure is shown in Figure 5.

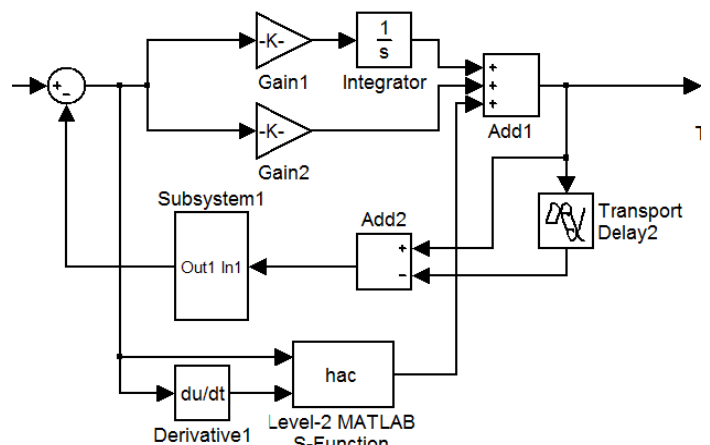

Fig -5: Simulating map of the hybrid controller HAC-PI

According hedge algebras approach, the controller HAC described in Figure 5 is designed according to the following steps [1], [2]:

Step 1: Identify the components of the hedge algebras for input and output variables.

Hedge algebras for linguistic variables Le, Lce, Lu of the variables e, ce, u include:

- 1) The set of generating element $G = \{S, B\}$, with $c^- = S$ (Small) and $c^+ = B$ (Big).
- 2) The elements 0, W and 1 are the smallest elements, the neutral element and the greatest element respectively.
- 3) The set of selected hedges: $H^- = \{L \text{ (Little)}\}$ and $H^+ = \{V \text{ (Very)}\}$.
- 4) The fuzzy parameters of hedge algebras is determined by genetic algorithm according to Table 1.

Table -1: Fuzzy parameters of hedge algebras for the variables Le, Lce and Lu

	Le	Lce	Lu
$\theta = fm(S)$	0.5	0.5	0.5
$\alpha = \mu(L)$	0.2	0.3889	0.8

Sign relationship of the hedges to other ones and the generating elements are identified as the sign table (Table 2) as follows:

Table -2: Sign relationship of the hedges and the generating elements

	V	L	S	B
V	+	+	-	+
L	-	-	+	-

Step 2: Set up the rule set with linguistic label of hedge algebras

The linguistic labels in hedge algebras is shown in Table 3. Rule set deduced according to hedge algebras is qualitatively constructed by the control rules shown in Table 4.

Table -3: The linguistic labels of the linguistic variable

Le, Lce	VS	-	LS	W	LB	-	VB
Lu	VS	S	LS	W	LB	B	VB

Table -4: Table of control rules HAC

Le \ Lce	VS	LS	W	LB	VB
VS	VS	VS	S	LS	W
LS	VS	S	LS	W	LB
W	S	LS	W	LB	B
LB	LS	W	LB	B	VB
VB	W	LB	B	VB	VB

It can be interpreted for the approximation inference rule applied to the controller using hedge algebras in Table 4 as follows:

- If $Le = VS$ and $Lce = VS$ then $Lu = VS$
- If $Le = VS$ and $Lce = LS$ then $Lu = VS$
- If $Le = LB$ and $Lce = LB$ then $Lu = B$
- If $Le = VB$ and $Lce = VB$ then $Lu = VB$

Step 3: Computing the semantically quantifying values from language terms in rule table (Table 5) and build input and output relationship surface to the S_{real} :

With an identifying set of fuzzy parameter, semantically quantifying values is recursively determined by the Semantically Quantifying Mapping function (SQM - Semantically Quantifying Mapping) ν as follows [1]:

$$\begin{aligned}
 \nu_{fm}(W) &= \theta = fm(c^-), \nu_{fm}(c^-) = \theta - \alpha fm(c^-) = \beta fm(c^-) \\
 \nu_{fm}(c^+) &= \theta + \alpha fm(c^+) \\
 \nu_{fm}(h_j c) &= \nu_{fm}(c) + \\
 &+ sgn(h_j c) \left\{ fm(h_j c) - \frac{1}{2} [1 + sgn(h_1, h_j)(\beta - \alpha)] fm(h_j c) \right\}
 \end{aligned}
 \tag{3}$$

Where:

- $fm: X \rightarrow [0, 1]$ is called the fuzzy measurement:
 $fm(h_j c) = \mu(h_j) fm(c), c \in G, j \in \{-1, 1\}$
 (4)
- $sgn: X \rightarrow \{-1, 1\}$ is the sign function which is recursively defined as follows:
 If $h \in H, c \in \{c^-, c^+\}$ then $sgn(c^+) = +1$ and $sgn(c^-) = -1$
 $\{h \in H^+ | sgn(h) = +1\}$ and $\{h \in H^- | sgn(h) = -1\}$
 $sgn(hc) = sgn(h) \times sgn(c)$
- $sgn(h_1, h_j)$ is determined through sign table (Table 2)

Basing on (3) and the parameters in Table 1, we can compute the semantically quantifying values of the language terms in rule table (Table 5) as follows:

$$\begin{aligned}
 \nu(VS) &= \theta(1-\alpha)(1-\alpha); \nu(S) = \theta(1-\alpha); \\
 \nu(LS) &= \theta(1-\alpha+\alpha^2); \nu(W) = \theta; \\
 \nu(LB) &= \theta+\alpha(1-\theta)(1-\alpha); \nu(B) = \theta+(1-\theta)\alpha; \\
 \nu(VB) &= \theta+\alpha(1-\theta)(2-\alpha)
 \end{aligned}$$

Table -5: Semantically quantifying values of variables

Le \ Lce	VS (0.32)	LS (0.48)	W (0.50)	LB (0.52)	VB (0.68)
VS (0.1867)	VS (0.02)	VS (0.02)	S (0.10)	LS (0.18)	W (0.50)
LS (0.4244)	VS (0.02)	S (0.10)	LS (0.18)	W (0.50)	LB (0.82)
W (0.5000)	S (0.10)	LS (0.18)	W (0.50)	LB (0.82)	B (0.90)
LB (0.5756)	LS (0.18)	W (0.50)	LB (0.82)	B (0.90)	VB (0.98)
VB (0.8133)	W (0.50)	LB (0.82)	B (0.90)	VB (0.98)	VB (0.98)

According to the points calculated in Table 5, we present the surface S_{real} corresponding as in Figure 6.

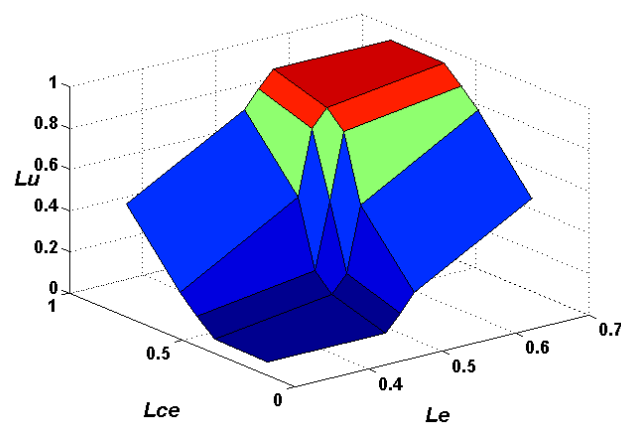

Fig -6: S_{real} of the controller HAC

6. Simulation results and comments

To evaluate the effectiveness of the hybrid controller HAC-PI, we design and compare it with classic PI controller.

Transfer function DO for the verifiable simulation referred by [9]:

$$G(s) = \frac{K}{(T_1s + 1)(T_2s + 1)} e^{-\tau s} \tag{5}$$

where $K=0.8, T1=12, T2=100, \tau=60$.

As can be shown in Table 6, the expected value of DO is set up. The purpose of this change is to verify the response of the control method when the order quantity changes.

Table 6. Expected values of DO change in time

t [s]	0 – 200	200– 400	400 – 600	600 – 900
u_{dc}^* [mg/l]	1	3	-1	2

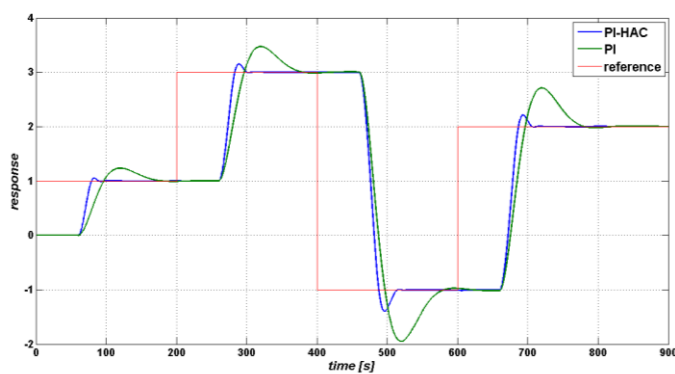

Fig -7: The simulation results of the PI controller and hybrid controller PI-HAC

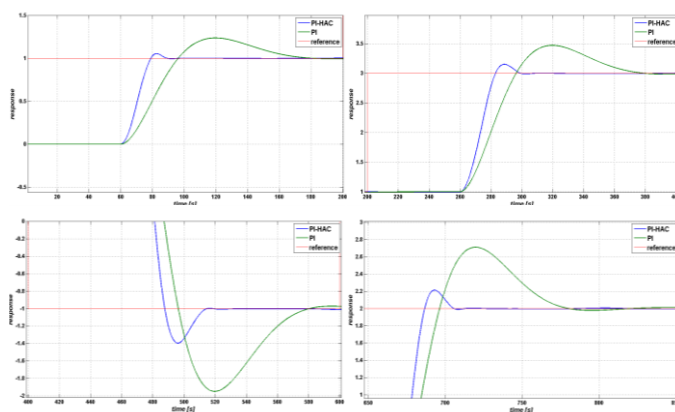

Fig -8: Extracting control characteristics with the different assigned values DO

The parameters of the PI controller for the DO obtained after using the algorithm GA is $K_P = 5,2, T_I = 0,1$. For the hybrid controller, besides components PI, there is also one more controller that uses hedge algebras and the

parameters as described in part 5. The results are shown in Figure 7 and Figure 8.

The simulation results shown in Figure 7, Figure 8 and Table 6 illustrate the response of the controllers to change the reference line DO in time. With the classic controller PI, the response shows the largest overshoot and settling time. These values are much lower than the time the hybrid control HAC-PI is used and it gives the results for the terms of the overshoot and the settling time.

Table -7: Operating parameters of the controllers

Time [s]		PI	HAC-PI
		0-200	
	The time delay	60	60
	The rise time	53.55	20.43
	The settling time	133.5	34.56
	% overshoot	0.64%	0.1%
200-400			
	The time delay	60	60
	The rise time	53.82	25.65
	The settling time	135.6	41.85
	% overshoot	1.4%	0.1%
400-600			
	The time delay	60	60
	The rise time	54.2	32.4
	The settling time	135.2	59.5
	% overshoot	2.7%	0.8%
600-900			
	The time delay	60	60
	The rise time	53.91	29.7
	The settling time	134.9	52.3
	% overshoot	2%	0.5%

7. Conclusion

This paper proposes a hybrid controller based on the combination of the controller used algebras and classic PI one applied for dissolved oxygen in the process of activated sludge wastewater treatment the provincial. As far as we are concerned, this is the first time a hybrid controller using algebras has been successfully applied in this field. The effectiveness of the proposed method was evaluated through a comparison with classic PI controller. The simulations were performed and the results have been gathered in a large and reasonable scale of DO. Based on the above results, it can be seen that the HAC-PI hybrid controller has proven to be the best choice in terms of its superior performance for the time required for the establishment and the overshoot in process followed the reference order quantity DO. Besides, the computational efficiency of the hybrid controller has proven to be satisfactory and similar to the other controllers [8]. Hybrid controller HAC-PI is surely a promising alternative to existing solutions in the field of control.

REFERENCES

- [1] Binh Lam Hoang, Fei Luo, Duy Nguyen Tien, Phuong Huy Nguyen, "Dissolved Oxygen Control of the Activated Sludge Wastewater Treatment Process Using Hedge Algebraic Control", *Biomedical Engineering and Informatics (BMEI), 7th International Conference (BMEI 2014)*, pp 827 – 832, 2014
- [2] C.H. Nguyen, N. L. Vu, X. V. Le , "optimal hedge-algebra-based controller: Design and application", *Fuzzy Set. Syst.*, 159, pp. 968-989, 2008
- [3] Goldberg D.E, *Genetic Algorithms in Search, Optimization, and Machine Learning*, Addison-Wesley, 1989
- [4] Hamilton, R., Braun, B., Dare, R., Koopman, B., & Svoronos, S. A. , "Control issues and challenges in wastewater treatment plants", *IEEE Control Systems Magazine*, 26, pp. 63–69, 2006
- [5] Holanda, B., Domokos, E., R' edey, ' A., & Fazakas, J., "Dissolved oxygen control of the activated sludge wastewater treatment process using model predictive control", *Computers & Chemical Engineering*, 32, 1270–1278, 2008
- [6] Jain, L.C., and Jain R.K, *Hybrid Intelligent Engineering Systems*, World Scientific Publishing, 1997
- [7] L. Åmand, Control of aeration systems in activated sludge processes - a review, IVL Swedish Environmental Research Institute/Department of Information Technology, Uppsala University. (E-mail: linda.amand@ivl.se), 2013
- [8] Vukadinović, Dinko, Mateo Bašić, Cat Ho Nguyen, Nhu Lan Vu, and Tien Duy Nguyen , "Hedge-algebra-based voltage controller for a self-excited induction generator", *Control Engineering Practice*, pp. 78-90, 2014
- [9] YE Hong-tao, LI Zhen-qiang, LUO Wen-guang , "Dissolved Oxygen Control of the Activated Sludge Wastewater Treatment Process Using Adaptive Fuzzy PID Control", *Proceedings of the 32nd Chinese Control Conference*, pp 7510-7513, 2013

BIOGRAPHIES



Fei Luo: Professor in South China University of Technology. Publications: more than 100 papers have been published, in which: International journals (SCI, EI, ISTEP): 23
Research interests: Automation, Computer network control, model identification, system control



Binh Lam Hoang: PhD student at College of Automation Science and engineering south China university of technology.
Research interests: Engineering controls, Fuzzy logics, Fuzzy control.



Nguyen Tien Duy: PhD student at Institute of Information Technology, Vietnam Academy of Science and Technology, Hanoi, Vietnam. Research interests: Engineering controls, Fuzzy logics, Fuzzy control and Computing.



Phuong Huy Nguyen: PhD in Telecommunication Engineering at Hanoi University of Technology, Vietnam.
Research interests: Soft computing, Fuzzy control.