

Role of DCF technique for enhancing optical fiber communication System utility

Ranjita Rout¹ Subhrajit Pradhan² Srikanta Patnaik³

Assistant Professor, Department of Applied Electronics & Instrumentation, GIET, Gunupur, Odisha, India

Assistant Professor, Department of Applied Electronics & Instrumentation, GIET, Gunupur, Odisha, India

Assistant Professor, Department of Electronics & Communication, GIET, Gunupur, Odisha, India

Abstract-Dispersion compensation is the most important feature required in optical fiber communication system because absence of it leads to pulse spreading that causes the output pulses to overlap. If an input pulse is caused to spread such that the rate of change of the input exceeds the dispersion limit of the fiber, the output data will become indiscernible. The most commonly used dispersion compensation are Dispersion compensation fiber (DCF) which compensates dispersion at 1310nm and 1550 nm and Fiber Bragg gratings (FBG) which compensate dispersion at wavelength around 1550nm. DCF techniques increase the total losses non-linear effects and costs of optical transmission system. FBG helps in decreasing the cost of the system and also have low insertion loss.

In this paper we briefly review the work on dispersion compensating fibers (DCFs) in the last few years. Starting with the basic principle behind DCF, its need for upgrading the 1310 nm optical fiber links is discussed. The latest trend in optical communication has been to use dense wavelength division multiplexed (DWDM) systems in the gain window of an optical fiber amplifier. However, nonlinear effects like four wave mixing (FWM) impose serious limitations. To overcome this difficulty use of fibers with non-zero dispersion has been suggested. For long distance repeater less transmission this dispersion will go on accumulating and will limit the number of bits one can send at each wavelength. Properly designed dispersion compensating fibers can overcome this difficulty.

Key word:*-optical fibers, Dispersion in optical fiber, Dispersion compensating fibers (DCF),DCF model*

I.INTRODUCTION

The optimal design and application of optical fiber are very important to the transmission quality of optical fiber transmission system. Therefore, it is very necessary to investigate the transmission characteristics of optical fiber. And the main goal of communication systems is to increase the transmission distance. Loss and dispersion are the major factor that affect fiber-optical communication being the high-capacity develops. The EDFA is the gigantic change happened in the fiber-optical communication system, the loss is no longer the major factor to restrict the fiber optical transmission. Since EDFA works in 1550 nm wave band, the average Single Mode Fiber (SMF) dispersion value in that wave band is very big, about 15-20ps / (40 nm.km-1). It is easy to see that the dispersion become the major factor that restricts long distance fiber-optic communication. Dispersion is defined as because of the different frequency or mode of light pulse in fiber transmits at different rates, so that these frequency components or modes receive the fiber terminals at different time. It can cause in tolerable amounts of distortions that ultimately lead to errors. In single-mode fiber performance is primarily limited by chromatic dispersion (also called group velocity dispersion), which occurs because the index of the glass varies slightly depending on the wavelength of the light, and light from real optical transmitters necessarily has nonzero spectral width (due to modulation). Polarization mode dispersion, another source of limitation, occurs because although the single-mode fiber can sustain only one transverse mode, it can carry this mode with two different polarizations, and slight imperfections or distortions in a fiber can alter the propagation velocities for the two polarizations. This phenomenon is called birefringence.

If the incident light has two polarization components, due to refractive difference between the fast axis and slow axis, the transmit rate of two polarization components will be different. Because the randomness of fiber birefringence changes, the group velocity of different polarization direction is also random, this will result in the output pulse broadening. The influence of dispersion on system performance is also reflected in the optical fiber nonlinear effects. Dispersion increased the pulse shape distortion caused by the self-phase modulation dispersion (SPM); the other hand, dispersion in WDM systems can also increase the cross-phase modulation, four-wave mixing (FWM) and other nonlinear effects.

II. DISPERSION

Dispersion is defined as pulse spreading in an optical fiber. As a pulse of light propagates through a fiber, elements such as numerical aperture, core diameter, refractive index profile, wavelength, and laser line width cause the pulse to broaden. Dispersion increases along the fiber length. The overall effect of dispersion on the performance of a fiber optic system is known as Inter symbol Interference (ISI). Inter symbol interference occurs when the pulse spreading caused by dispersion causes the output pulses of a system to overlap, rendering them undetectable.

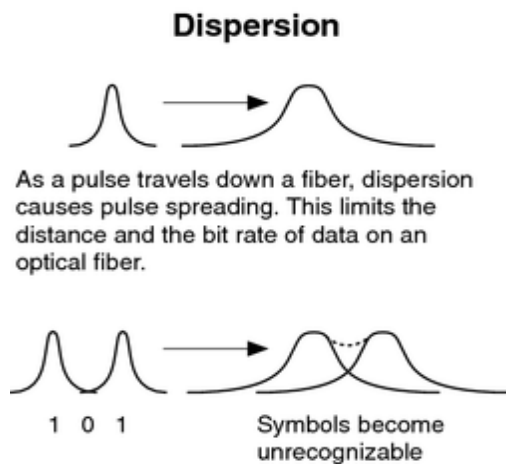

Figure 1: Dispersion or pulse spreading in optical fiber

(a) Types of Dispersion

Dispersion is generally divided into three categories: modal dispersion, chromatic dispersion and Polarization mode dispersion

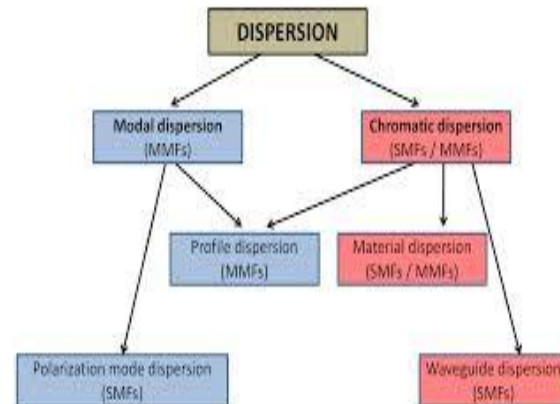

Figure 2: Types of Dispersion

Modal dispersion is defined as pulse spreading caused by the time delay between lower-order modes and higher-order modes. Modal dispersion is problematic in multimode fiber, causing bandwidth limitation.

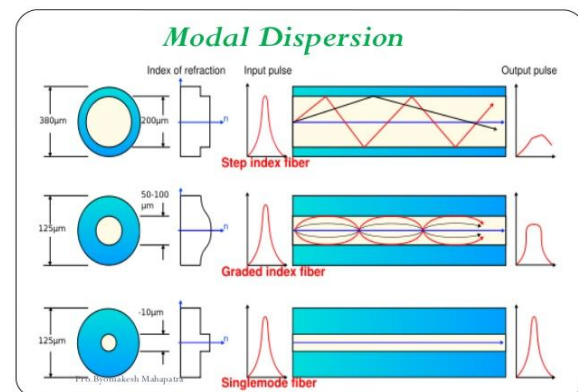

Figure 3: Modal Dispersion in different fibers

Chromatic Dispersion (CD) is pulse spreading due to the fact that different wavelengths of light propagate at slightly different velocities through the fiber because the index of refraction of glass fiber is a wavelength-dependent quantity; different wavelengths propagate at different velocities.

Chromatic dispersion consists of two parts: material dispersion and waveguide dispersion.

Material dispersion

It is due to the wavelength dependency on the index of refraction of glass i.e. refractive index of the core varies as a function of wavelength.

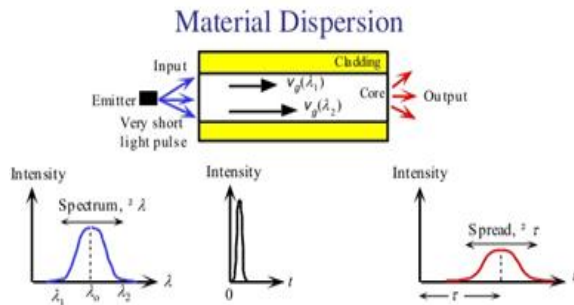

Figure 4: Material Dispersion

Waveguide dispersion

It is due to the physical structure of the waveguide. In a simple step-index profile fiber, waveguide dispersion is not a major factor, but in fibers with more complex index profiles, waveguide dispersion can be more significant.

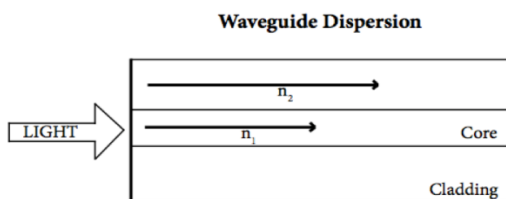

Figure 5: Waveguide Dispersion

Polarization Mode Dispersion (PMD) occurs due to birefringence along the length of the fiber that causes different polarization modes to travel at different speeds which will lead to rotation of polarization orientation along the fiber.

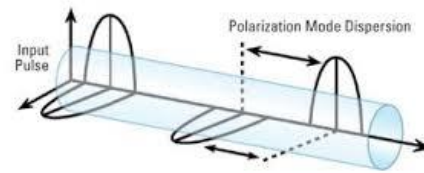

Figure 6: Polarization Mode Dispersion

In order to remove the spreading of the optical or light pulses, the dispersion compensation is the most important feature required in optical fiber communication system.

III. DISPERSION COMPENSATION SCHEME

The most commonly employed techniques for dispersion compensation are as follows:

DCF is a loop of fiber having negative dispersion equal to the dispersion of the transmitting fiber. It can be inserted at either beginning (pre-compensation techniques) or end (post-compensation techniques) between two optical amplifiers or mix compensation. But it gives large footprint and insertion losses.

Electronic equalization techniques are used in this method. Since there is direct detection at the receiver, linear distortions in the optical domain, e.g. chromatic dispersion, are translated into non linear distortions after optical-to-electrical conversion. It is due to this reason that the concept of nonlinear cancellation and nonlinear channel modeling is implemented. For this mainly feed forward equalizer (FFE) and decision feedback equalizers (DFE) structures are used. EDC slows down the speed of communication since it slows down the digital to analog conversion.

Optical Fiber Bragg Grating (FBG) has recently found a practical application in compensation of Dispersion-broadening in long-haul communication. In this, Chirped Fiber Grating (CFG) is preferred. CFG is a small all-fiber passive device with low insertion loss that is compatible with the transmission system and CFG's dispersion can be easily adjusted. CFG should be located in-line for optimum results.

This is a preferred technique because of its advantages including small footprint, low insertion loss, dispersion slope compensation and negligible non-

linear effects. But the architectures using FBG is complex.

Digital filters using Digital Signal Processing (DSP) can be used for compensating the chromatic dispersion. They provide fixed as well as tunable dispersion compensation for wavelength division multiplexed system. Popularly used filter is lossless all-pass optical filters for fiber dispersion compensation, which can approximate any desired phase response while maintaining a constant, unity amplitude response.

Other filters used for dispersion compensation are band pass filter, Gaussian filters, Super-Gaussian filters, Butterworth filters and microwave photonic filter .

The dispersion compensation system in the WDM: The dispersion compensation system in the WDM is studied in this paper. Based on optical transmission equation, considering the various types of nonlinear effects and the impact of EDF A(Erbium-doped Fiber Amplifiers) , system simulation models are established. According to relative position of DCF and single-mode fiber, post-compensation, pre-compensation, mix compensation is proposed. DCF Pre-compensation scheme achieve dispersion compensation by place the DCF before a certain conventional single-mode fiber, or after the optical transmitter. Post -compensation scheme achieve dispersion compensation by place the DCF after a certain conventional single-mode fiber, or before the optical transmitter. Mix compensation scheme is consist of post compensation and pre-compensation .Different location on the system will generate different nonlinear effects. In order to improve overall system performance and reduced as much as possible the transmission performance influenced by the dispersion, several dispersion compensation scheme were proposed . The Simulation of three dispersion compensation system is shown in Figure 7.

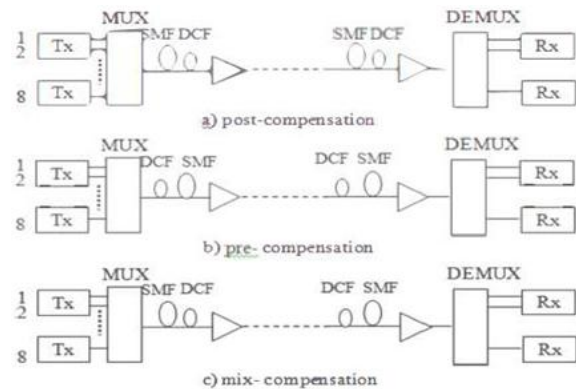

Figure 7: Three dispersion compensation techniques

IV.OBSERVATION

In optical fiber communication systems, only optical signal to noise ratio (OSNR) could not accurately measure the system performance, especially in WDM systems. Typically, as a quality factor, Q is a one of the important indicators to measure the optical performance by which to characterize the BER. Figure 9 display the influence of input optical power on the performance of transmission system.

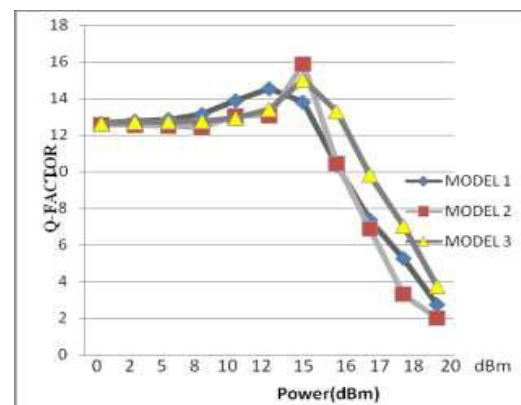

Figure 8: Comparison of transmission power vs. Q factor influence of three compensation system

From the figure 8 we can find that with the input optical power increased to about 9dB, the Q factor increases. When the input optical power approaches 16dB, the Q factor becomes the maximum. When the input optical power is greater than 16dB the quality factor decreased gradually and the error performance is gradually degraded.

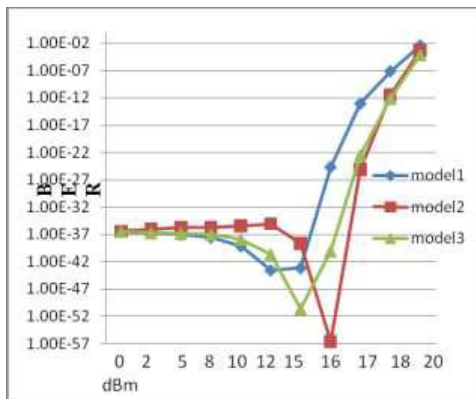

Figure 9: Comparison of transmission power vs. BER of three compensation system

In fig 9 when the input optical power is greater than 16dB, the nonlinear effect increases rapidly, making the system BER performance is degraded rapidly. From Figure 8 & 9 in the case of the fiber optical power equal, the quality factor of mix compensation is greater than the two other kinds of dispersion compensation. Through the whole system study found that the performance of mix compensation system is best in the long-distance high-speed WDM systems.

V.CONCLUSION

In conclusion it is found that dispersion compensation is necessary to reduce losses and cost of the system. Dispersion compensation can be done through two different methods i.e dispersion compensation fiber and fiber Bragg gratings. By comparing the two methods we can see that Using DCF techniques increase the total losses nonlinear effects and costs of optical transmission system. FBG helps in decreasing the cost of the system and also have low insertion loss. Using DCF for dispersion compensation in 40 GB/s WDM system is an effective solution. The attenuation of DCF fiber is not null. Thus, the attenuation of DCF fiber will produce impairment to the signal quality as well as that of SMF & attenuation can be compensated with optical fiber amplifier such as EDF A. Mix-compensation scheme can greatly reduce the fiber nonlinear effects, this program better than the pre compensation and post compensation program. For this compensation scheme, the effect of laser average power is just contrary to the previous

situations. A moderate bigger value of laser average power is favorable to the performance of the transmission system the input fiber power is taken dB, the about 16 corresponding BER performance is better.

REFERENCES:

- [1] G. Keiser, Optical fiber communications. Wiley India, 2011.
- [2] G. Keiser, Signal Degradation in Optical Fiber, pp. 113–115. McGraw-Hill, 2000.
- [3] G. K. S. Devra, "Different compensation techniques to compensate chromatic dispersion in fiber optics," International Journal of Engineering and Information Technology, vol. 3, no. 1, pp. 1–4, 2011.
- [4] J. Toulouse, "Optical nonlinearities in fibers: review, recent examples, and systems applications," Light wave Technology, Journal of, vol. 23, no. 11, pp. 3625–3641, 2005.
- [5] P. Nouchi, B. Dany, J.-F. Campion, L.-A. de Montmorillon, P. Sillard, and A. Bertaina, "Optical communication and fiber design," in Annales des t'el'ecomunications, vol. 58, pp. 1586–1602, Springer, 2003.
- [6] Mochida Y, Yamaguchi N, Ishikawa G, "Technology-oriented review and vision of 40Gb/s-based optical transport Networks", Journal of light-wave technology. PP. 2272-228,12002,20(12)
- [7] Zhang Hongb in, Q iu Kun, "Emulation of characteristics of optical fiber transmission for a 10Gb/s single channel situation," acta photonica sinica 2001 vol.30 No.6 715-720
- [8] Omae T, "Universal conditions for estimating the nonlinear refractive index n2 of dispersion compensating fibers by the CW- 43 SPM method", IEEE Photon. Technol. Lett., Vol 13. No.6, pp. 571-573, Nov, 2001.
- [9] Mohammad. Amin. Dallaali, "Malin Premaratne Power and dispersion constrained optimization of optical links with unequally spaced repeater modules", Optical Fiber Technology, Vol 13, No 4, pp.309-317, October. 2007.
- [10] Raman kashyap. "Fiber Bragg gratings". 3th edition. Academic press.(1999).
- [11] Othonos.a and kyriacos k . "Fiber Bragg gratings: fundamentals and applications in telecommunications

and sensing". *Artech house, Boston* pp. 189-269. (1999).

[12] R.S. Kaler, Ajay K.Sharma and T.S. Kamal "Comparison of pre-, post- and symmetrical-dispersion compensation schemes for 10 Gb/sNRZ links using standard and dispersion compensated fibers". *Optics Communications* 209 (2002) 107-123