

Rapid Therapeutic Imaging in 3D Ultrasound Mainframe Tomography

***¹Mrs. Akila S., *² Ms. Siva sankari A., *³ Mrs. Lakshmi R.,**

**¹ M.Phil Research Scholar, Department of Computer Science D.K.M. College for Women (Autonomous), Vellore, TamilNadu, India.*

**²Head of the Department Computer Science, D.K.M. College for Women (Autonomous), Vellore, TamilNadu, India.*

**³ Assistant Professor, Department of Computer Science, D.K.M. College for Women (Autonomous), Vellore, TamilNadu, India.*

Abstract - *As today's standard screening methods frequently fail to detect breast cancer before metastases have developed, early diagnosis is still a major challenge. With the promise of high-quality volume images, three-dimensional ultrasound computer tomography is likely to improve this situation, but has high computational needs. In this work, we investigate the acceleration of the ray-based transmission reconstruction by a GPU-based implementation of the iterative numerical optimization algorithm TVAL3. We identified the regular and transposed sparse-matrix-vector multiply as the performance limiting operations. For accelerated reconstruction we propose two different concepts and devise a hybrid scheme as optimal configuration. In addition we investigate multi-GPU scalability and derive the optimal number of devices for our two primary use-cases: a fast preview mode and a high-resolution mode. In order to achieve a fair estimation of the speedup, we compare our implementation to an optimized CPU version of the algorithm. Using our accelerated implementation we reconstructed a preview 3D volume with 24,576 unknowns, a voxel size of (8 mm)³ and approximately 200,000 equations in 0.5 s. A high-resolution volume with 1,572,864 unknowns, a voxel size of (2mm)³ and approximately 1.6 million equations was reconstructed in 23 s. This constitutes an acceleration of over one order of magnitude in comparison to the optimized CPU version.*

Key Words: *Medical Transcription system, Medical Care, Topology control system, GPU, High Quality Image*

I. INTRODUCTION

This century will pass away, but the birth of medical computing and its rewards to advances in medicine will usher in a new plate of technological innovations with a focus on ideal and convenient delivery of medical services. Both medicine and computers are growing at a rapid rate. Undoubtedly the growth in medicine has benefited much from the growth in computers. Precise diagnosis, fast data and voice communication, instant generation of patient data, invention of biomedical equipment and medical laser technology are a few of these lifesaving rewards from computers to medicine. Even then, the challenges and potentials remain plentiful as both medical and computer scientists plan to cope with the waves of new computer technology for the future. This paper discusses the prospective of future medical computing by citing new computer innovations that will have impact on medical delivery system.

Early cancer diagnosis is still a major challenge. The standard screening methods often detect cancer in a state when metastases have already developed. The presence of metastases decreases the probability of survival significantly. A more sensitive tool for breast cancer diagnosis could lead to diagnoses in an earlier state, i.e. before metastases are generated.

The standard method for breast cancer diagnosis is X-ray mammography assisted by sonography and sometimes Magnetic Resonance Imaging (MRI) for further investigation. X-ray mammography produces images with high spatial resolution, but has the drawback of being a 2D projection. Thus, the lesions appear embedded in a highly heterogeneous background, which makes the detection of small lesions difficult. Additionally, X-ray mammography is not feasible for younger women with predominant glandular tissue. Conventional ultrasound imaging produces images of anisotropic resolution, which are hard to read due to the high noise level. MRI is expensive and has low specificity. In conclusion, a low-cost 3D ultrasound imaging with approximately the resolution of X-ray mammography would be the instrument of first choice, because it avoids radiation doses and breast compression.

At the Forschungszentrum Karlsruhe, in the Institute for Data Processing and Electronics, we are developing a new low-cost ultrasound computer tomography (USCT) in order to support reproducible 3D imaging with sub-wavelength resolution. Additionally, from the same data the local distribution of speed of sound and attenuation can be derived, which are known to be different in cancer tissues. In this paper, a short introduction into the principles of USCT is given, the configurations and the results of a 2D and a 3D demonstration system are presented.

1.1 PROBLEM DEFINITION

1. A large number of ultrasound sensors are needed to obtain the necessary resolution. These sensors have to be low cost to restrict the overall price of the system. Additionally, they have to be very similar in their characteristics (resonance frequency and bandwidth) to ensure homogenous insonification and recording of the object. To submit a spherical wave, the emitters have to be small, ideally smaller than the submitted wavelength. Thus, the amplitude of the emitted pressure is low, resulting in a low signal-to-noise ratio.

2. For sub-millimeter resolution in 3D, the data acquisition time has to be as short as possible to correct for patient movement. Though post-beam-forming enables fast recording.

3. The image reconstruction, i.e. the post-beam forming, has a high computational complexity, i.e. the number of A-scans (pressure over time at one receiver) to be recorded is given by the number of receivers times the number of senders and each of these A-scans has to be processed for each 3D image point (voxel).

4. The dynamic range of the received signals is large. The transmission signals may be attenuated by the breast or only go through water; the attenuation of the pressure signal in the breast may be as large as 58 dB for 20 cm at 3 MHz. On the other hand, the changes in impedance between normal and cancerous tissue are only small leading to a reflected wave of the order of approximately 0.03%.

II. MEDICAL TECHNOLOGY

(1) ANIMAL CLONING AND THE HUMAN GENOME PROJECT

Another advancement in technology occurred alongside the controversial achievement of cloning a mammal. Dolly, the sheep, was the first animal to be cloned through a process of nuclear transfer from an adult cell. Following the success, great efforts have been made to crack the human genome code, which could be used to find

permanent solutions to a variety of hereditary medical problems like diabetes and Alzheimer's disease.

(2) NANO MEDICAL TECHNOLOGY

In 1959, when Richard Feynman, a renowned physicist, gave his famous, "There's Plenty of Room at the Bottom," speech at the American Physical Society meeting in Caltech, he could have never fathomed the implications his speech would have on the future of medical technology. Feynman spoke about the strength, as well as the potential ability, of nanotechnology in a variety of fields. Nanotechnology is based on the premise that all known elements change physically at the atomic and molecular level.

(3) USE OF GENETICS IN HEALTHCARE AND MEDICINE

Genetics revolves around the study of genes. The term 'genetics' is derived from the Greek word 'geneticos,' which translates to 'origin.' Genetics is of extreme value for the diagnosis and treatment of hereditary disorders. In fact, medical genetics' primary ambition is to develop technology that can identify and treat hereditary disorders.

We have summarized the current state of biomedical informatics in a variety of application areas and have reflected on the development of the field during the past 50 years. To provide a background for our discussions, we opened the book with a glimpse into the future a vision of medical practice when individual physicians routinely and conveniently use computers and electronic health records to help with information management, communication, and clinical decision making.

(4) PROGRESS IN BIOMEDICAL COMPUTING

We begin by looking back at the changes in biomedical computing since the first edition of this book was published in 1990. Then we look ahead to the not-too-distant future—presenting a few scenarios that we can extrapolate from the current trends in the field. These scenarios provide perspective on the ways that computers may pervade clinical practice and the biological science laboratory. A key aspect of the clinical scenarios is the extent to which, unlike most specialized medical paraphernalia of today, medical computing applications are integrated into routine medical practice rather than used on an occasional basis. In much the same way, computers are becoming a crucial part of the analysis of data in the research laboratory, especially in the areas of genomics and proteomics, where the amount of incoming data is very large. The realization of a highly integrated environment depends on the solution of technological challenges, such as integrating information from multiple data sources and making the integrated information accessible to professionals when, where, and in the form

that it is needed. Integration of medical and biological information also encompasses social issues, such as defining the appropriate role of computers in the workplace, resolving questions of legal liability and ethics related to biomedical computing, and assessing the effects of computer-based technology on health care costs.

2.1 LOW-COST, HIGH-QUALITY TELEMEDICINE:

The telemedicine experiments of the mid-1990s were dependent on specialized equipment and expensive special-use communications lines. This has evolved such that the Internet is a common vehicle for linking medical experts with other clinicians and patients at a distance (National Research Council, 2000; Shortliffe, 2000). In the future, the Internet will be able to support clear video images routinely, with high-fidelity audio links to support listening to the heart and lungs, and common computing platforms at both ends of the links to make telemedicine a cost-effective form of medical practice. Patients will avoid unnecessary travel from rural settings to major medical centers, primary care clinicians will have expert consultation delivered to them in their offices in a highly personalized fashion, and patients will accomplish in single office visits what now often requires multiple visits and major inconvenience.

2.2 REMOTE CONSULTATION:

Quick and easy electronic access between clinical providers to discuss patient cases will improve access to expert patient care and enhance patient satisfaction.

For example, an attending physician, residents, and medical students in a community clinic who treat a patient with an unusual skin lesion will obtain immediate teleconsultation with a dermatologist at a regional medical center. The remote medical team will learn from the dermatologist, the expert will receive clear, diagnostic-quality images of the lesion, and the patient will promptly receive a specialist's assessment. All too often today, patients, when referred to major centers, experience significant delays or fail to keep their appointments due to travel problems.

2.2.1 INTEGRATED HEALTH RECORDS:

We envision the day when citizens no longer will have multiple records of their health care encounters scattered throughout the offices of numerous physicians and the medical record rooms of multiple hospitals. Instead, their records will be linked electronically over the Internet so that each person has a single "virtual health record"—the distributed, but unified, summary of all the

health care they have received in their lives. Furthermore, this record will be secure, treated with respect and confidentiality, and released to providers only with the patient's permission or during times of medical emergency according to strictly defined and enforced criteria (National Research Council, 1997). Important steps have been taken recently to make this scenario more likely to happen.

The development of a National Health Information Infrastructure and adoption of nomenclature standards such as SNOMED-CT, and privacy rules such as Health Insurance Portability and Accountability Act (HIPAA) are contributing toward this goal. In 2004, President Bush announced a federal goal to implement ubiquitous electronic health records for all citizens within a decade.

2.3 COMPUTER-BASED LEARNING:

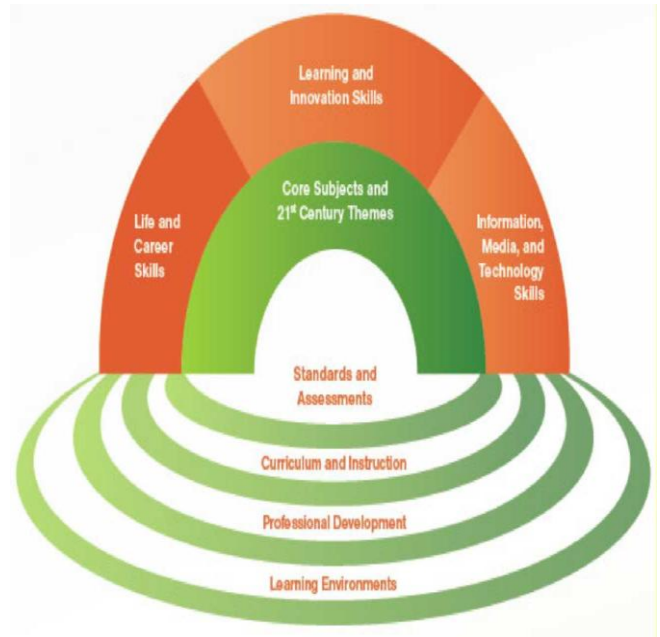

Fig1: COMPUTER BASED LEARNING

Soon, medical students on their orthopedics rotation, preparing to observe their first arthroscopic knee surgery, will be able to go the school's electronic learning center and use the Internet to access and manipulate a three-dimensional "virtual reality" model of the knee on a computer at the National Institutes of Health. They will use new immersive technologies to "enter" the model knee, to look from side to side to view and learn the anatomic structures and their spatial relationships, and to manipulate the model with a simulated arthroscopic, thus getting a surgeon's-eye view of the procedure before experiencing the real thing.

2.4 FRAMEWORK FOR CENTURY LEARNING

The Partnership for 21st Century Skills has created a way of looking at teaching and learning today. The elements include focusing on the core subjects, the areas identified in NCLB legislation; 21st century content, the emerging content areas such as: global awareness; financial, economic, business, and entrepreneurial literacy; civic literacy; and health/wellness awareness. They specifically address learning and thinking skills, including: critical thinking and problem-solving skills; communication; creativity and innovation; collaboration; contextual learning; and information and media literacy.

In addition, students and educators today must have ICT (Information and Communications Technology) literacy and use technology in the context of teaching and learning. The skills they need include such life skills as leadership, ethics, accountability, personal responsibility, self-direction, and more..

The Partnership's Framework is a unified, collective vision for 21st century learning. Among its elements are the standards, curriculum, environment, and assessments that districts must implement.

III. PATIENTS AND PROVIDER EDUCATION:

Health science schools are starting to provide distance-learning experiences via the Internet for postgraduate education, refresher courses, and home study by health science students. Eventually, clinicians will be able to prescribe specially selected video educational programs for patients that will be delivered to home television sets by a direct Internet connection. Our hospitals and clinics will use video servers over the Internet not only to deliver such materials to patients but also to provide continuing medical and nursing education to their staffs.

3.1 DISEASE MANAGEMENT:

High-speed Internet access via Digital Subscriber Line (DSL), cable, or satellite is now being offered to most families in the United States and more than 50 million households now have broadband connectivity. Soon, clinicians will move beyond the simple use of telephones for managing patient problems at a distance to using their visual senses as well via two-way video links. The infirm will receive "home visits" via video links, thus avoiding unnecessary office or emergency room visits, and care managers will have important new tools for monitoring patients that emphasize prevention rather than crisis management.

Over these last 5 years since these goals were elucidated, we have made significant progress toward meeting these long-term objectives for computer-assisted

learning, provider and patient communication, and medical care utilizing high-speed networks and fast, commodity computers. Similar changes have been taking place in the collection, interpretation, and dissemination of biological information. For example with the advent of very fast, multiprocessor supercomputers, researchers can begin to model biological processes such as the folding of a protein or the binding of a drug to a receptor site.

3.2 A COMPUTATIONAL MODEL OF PHYSIOLOGY:

It Can we create a simulation of the human body and estimate of the effects of medications on the diseased and no diseased portions of the body with sufficient fidelity to avoid most animal and early human testing of drugs? Having this simulation model would bring a tremendous benefit by reducing the number of years of testing that occurs for most drugs. However, the complexity of the task is daunting. Much of the path physiology needed to build this model is unknown, and even the parts that are known would create such a complex set of relationships that the computers models may be intractable given near-term computational capabilities. Furthermore, the genetic variation between individuals that is being studied in pharmacokinetics experiments greatly increases the complexity of the modeling process.

3.3 DESIGN OF NEW COMPOUNDS FOR MEDICAL AND INDUSTRIAL USE:

Can we design a protein or nucleic acid to have a specified function? The determination that a particular drug can be used to treat a medical condition has traditionally been done by testing a large collection of substances in the laboratory to see if any show in vitro activity. This step is then followed by extensive animal testing.

3.4 ENGINEERING NEW BIOLOGICAL PATHWAYS:

Can we devise methods for designing and implementing new metabolic capabilities for treating disease? The biological metabolic pathways of various species are being mapped out quite rapidly. It is interesting to observe the variation from species to species in pathways that perform similar metabolic functions for the animals. This suggests the possibility of building new metabolic pathways in areas such as inborn metabolic diseases. Some diseases, such as sickle cell anemia, have a single flaw that must be overcome.

3.5 DATA MINING FOR NEW KNOWLEDGE:

It Can we ask computer programs to examine data (in the context of our models) and create new knowledge? As we create large databases of measurements taken during clinical care, the question arises about finding new

patterns in those data. Exactly what effects does a drug have on various laboratory tests and measurements? If we have enough data collected across different patients but in similar situations, will we have enough statistical power to recognize unknown relationships? A large number of statistical approaches are being employed to perform a structured analysis of large data sets to learn new relationships.

These biological challenges are still likely to be unanswered as we approach the 10th edition of this textbook. Because they require the development of considerable biological knowledge, computational techniques, and new methodologies for analysis, they likely represent distant goals of biomedical computation.

IV. INTEGRATION OF COMPUTER-BASED TECHNOLOGIES

Most of the individual capabilities described in the preceding scenarios exist today in prototype form. What does not exist is an environment that brings together a large variety of computer-based support tools. The removal of barriers to integration requires both technological advances, such as the development of standards for data sharing and communication, and a better understanding of sociological issues, such as when computer use may be inappropriate or how the need for coordinated planning can overcome logistical barriers to connecting heterogeneous resources in a seamless fashion.

We can begin to assess the degree of connectivity in a medical center by asking simple questions. Can the laboratory computer communicate results to the computer that provides decision support, without a person having to reenter the data? Do the programs that provide decision support use the same terms to describe symptoms as do those that professionals use to perform electronic searches of citation databases?

Computer systems must be integrated into the medical setting in three ways. First, applications must fit the existing information flow in the settings where they are to be used. If the machine sits in a corner of the clinic, out of the normal traffic flow, and if there is another way to accomplish the specific task, then the computer system is likely to be ignored. User interfaces should be flexible and intuitive; just as the fields of a paper medical form can be completed in an arbitrary order, data-entry programs should allow users to enter information in any order.

Surgeons attempting so-called telepresence surgery over the Internet, bringing specialized expertise to an operating room possibly hundreds of miles away, will be unable to assist in the procedure if the movements they make with hand devices at one end are not instantly reflected in what they see happening with the actual instruments at the other end of the link. Can we guarantee

adequate response time for the telesurgery application not only on the major backbone networks but also on the last segments of wire, cable, or wireless network that come into offices and other remote settings?

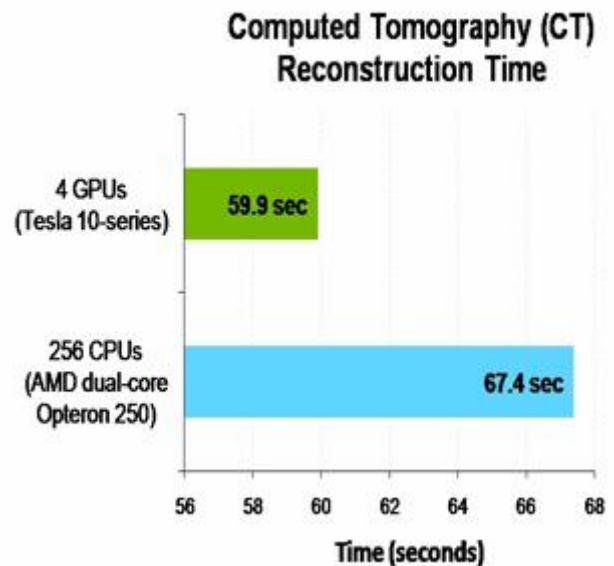

Fig2: COMPUTED TOMOGRAPHY

Second, computer systems should provide common access to all computer-based resources, so a user cannot tell where one program ends and another starts. Many of these systems have been developed independently, and most are completely incompatible. Ideally, users should not have to switch between computers, to stop one program and to start another, or even to use different sets of commands to obtain all the information they need. That the desired information resources may exist on multiple machines in different parts of the medical center or the country should be invisible to the user.

Third, the user interface must be both consistent across applications and easy to use, which may require multiple interface modalities, such as pointing, flexible spoken natural-language interfaces, and text input. Both at the user interface and internally, programs should use a common terminology to refer to frequently used concepts, such as a diagnosis, a symptom, or a laboratory test value.

We are seeing increasing amounts of medical information packed into smaller, more powerful computers, such as hand-sized personal digital assistants (PDAs). The configuration of computers is starting to change.

It shows a computer system that is worn attached to the body. Using spoken input or a keypad mounted on

the arm along with a heads-up display, the computer is inherently as mobile as the person using the system. Although this device may seem far in the future for medical care, a less sophisticated version of this equipment is used every day in the rental car business to check-in returning cars and print receipts. This is a fanciful figure from Wired Magazine that hints at the future effects of nanotechnology. Technology is not quite at the Fantastic Voyage level where miniature robots flow through the body repairing problems,

Mechanical devices. In the figure, the illustrator imagines miniature devices being used as an intervention to remove "smart dust" household sensors that might have been accidentally inhaled. Certainly, the ability to build sensors and treatment devices at such a small scale will influence future medical care, especially in the management of chronic diseases such as diabetes.

4.1 PREDICTIONS FOR THE FUTURE

Despite the profound changes already under way in the nation's health care system, advances in science and technology will ensure that laboratory investigation dominates the practice of medicine in the 21st century. Less clear is how the 2 traditions academic laboratory medicine, with its emphasis on teaching and research, and clinical pathology, with strengths in test strategy and interpretation of results will fare in an environment dominated by cost containment and a public increasingly concerned with avoidance of error and the assurance of quality.

The survival of both in such an environment depends on the ability to add value. That ability depends in turn on how effectively academic laboratory medicine and clinical pathology exploit advances in science and technology particularly advances in computer-based electronic communications and information technology to add value to the care of patients.

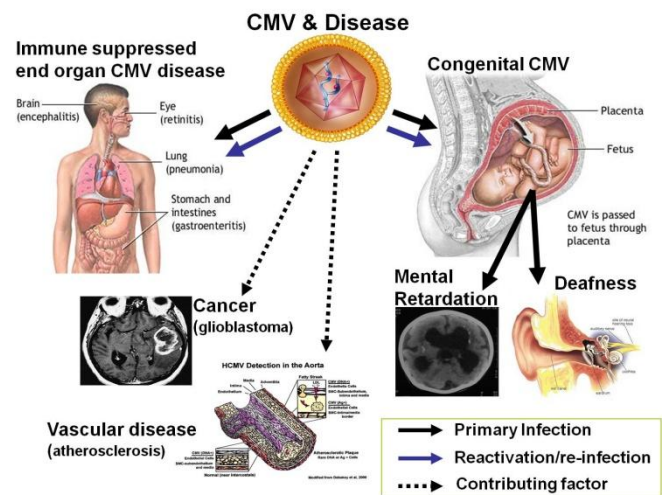

Fig 3: PREDICTIONS FOR THE FUTURE

4.2 TECHNOLOGY

Molecular techniques will dominate. At present, molecular testing is manual, labor-intensive, and expensive. In the future, molecular testing will be automated including specimen preparation, amplification, and detection using microarray probe technology. Microarray or biological chip (biochip) technology will allow thousands of biologic reactions to take place at once, analogous to computer chips simultaneously performing thousands of mathematical calculations. Applications will include screening for genetic indicators of disease, infectious disease detection, and the determination of cellular gene and protein expression profiles for the diagnosis and management of malignant neoplasm's.

Integrated testing platforms suitable for core or satellite facilities with the capability of performing hundreds of assays will be developed. Building on the pioneering work of Masahide Sasaki at the Kochi Medical School, Kochi, Japan,²¹ full scale automation of regional core laboratories will be further refined. The next century will see further development of more versatile point-of-care instrumentation with emphasis on modular robotic automation.

Dust takes place on a colony of the same name established on a harsh, unforgiving world many light-years from Earth. The single biggest hurdle that has to be overcome is how the heck do we get there? For any story set against a backdrop of galactic exploration, the author has to decide how the human race figures out how to travel beyond the bounds of the solar system.

Here are three well-known mechanisms for this: generation ships, faster than light travel, or wormholes. Generation ships are well within the realm of possibility but are not conducive to my futuristic galactic Republic, so I'll explore that topic another time. Meanwhile the

plausibility of faster-than-light travel took a blow this week, but at the moment, wormholes remain a theoretical possibility. Do a search for wormhole experiments and you'll find plenty of discussions on the topic from all corners of the academic spectrum.

V. THE EVOLUTION OF MEDICAL DEVICES

Another area of advancement in biomedical science covers cochlear implants. The primary goal of these implants is to use electrical stimulation safely to provide or restore functional hearing. The implants comprise a behind-the-ear processor in the external unit and a battery that uses a microphone to pick up sound, convert the sound to the digital realm, process and encode the digital signal into an RF signal, and then send it to the antenna in the headpiece (Figure 5). A magnet attracted to the internal receiver, which physicians surgically place just beneath the skin behind the ear, holds the headpiece in place. A hermetically sealed stimulator contains active electronic circuits that derive power from the RF signal, decode the signal, convert it into electric currents, and send them along wires threaded into the cochlea. The electrodes at the end of the wire stimulate the auditory nerve that connects to the central nervous system, which interprets electrical impulses as sound.

An external speech processor comprises a DSP, a power amplifier, and an RF transmitter. The DSP extracts features in the sound and converts them into a stream of data that the RF transmitter will transmit. The DSP also contains patient information in a memory map. An external-PC fitting program can set or modify the maps and other speech-processing parameters.

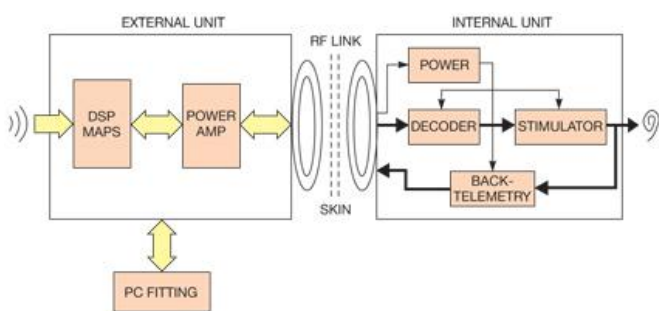

Fig4: a system monitors critical electrical and neural activities in the implants and transmits the activities back to the external unit

Advanced Bionics has developed an implantable electronics platform that benefits patients by offering more channels and the ability to generate virtual channels through current steering. According to Lee Hartley, vice president of R&D at the company, one of the biggest

challenges in developing sophisticated sound-processing sensors is improving the ability to hear in noisy listening environments. "Cochlear-implant recipients have a reduced ability to discriminate loudness levels and distinct frequency channels," he says.

"This [reduced ability] heightens the challenge of improving speech understanding and music appreciation; we need to intelligently separate information from noise."

The next major areas for significantly improving cochlear-implant systems and performance, says Hartley, include ubiquitous wireless connectivity to commercial devices, increasingly intelligent scene-analysis algorithms running at low power, and technologies that enable patients to receive cochlear-implant services from clinicians regardless of the patients' or clinicians' location. "Technology trends in the industry are moving toward system architectures and service models that will minimize the visibility of the entire cochlear-implant system," he explains. Hartley expects advances in IC technology to afford the delivery of wireless features and system-power reductions: "I see system design continuing to be modular in that recipients will customize their experience based on their changing needs."

Signal processing has greatly improved the performance of cochlear implants. Sound can be modeled either as a periodical source for voice sounds or as a noise source for unvoiced sounds. The resonance properties in the vocal tract filter the sounds' frequency spectrum. Alternatively, the source can be modeled as a carrier while the vocal tract acts as a modulator, reflecting the opening and closing of the mouth or the nose. The source typically varies rapidly, whereas the filters react more slowly.

The internal unit in all modern cochlear implants connects to the external unit by a transcutaneous RF link for the safety and convenience of the user. The RF link uses a pair of inductively coupled coils to transmit not only data but also power. The RF-transmission unit has some challenging tasks, such as efficiently amplifying signals and power and maintaining immunity to EMI. Its secondary functions are to provide reliable communication protocols, including a signal-modulation method; bit coding; frame coding; synchronization; and back-telemetry detection.

The RF design of cochlear implants presents many conflicting challenges that require careful compromises. For example, to extend battery life, the power transmitter must be a high-power, efficient design. Thus, most modern implants use a highly efficient Class E amplifier. Class E amplifiers are nonlinear, however, and their distorted waveform limits the data-transmission rate. Another challenge is the need for power-efficient transmitting and receiving coils. Operating the RF system at its resonant frequency, or at a narrow bandwidth, maximizes power, but the RF system must have unlimited

bandwidth for data transmission. And, although these devices call for high transmission frequency, this requirement dictates a large coil. In a practical, usable design, however, the size of the transmitting and the receiving coils must be small and cosmetically acceptable.

The receiver and stimulator in the internal unit act as the engine of the cochlear implant. The ASIC (shown in dashed box) performs the critical function of ensuring safe and reliable electrical stimulation. It has a forward pathway with a data decoder that recovers the digital information from the RF signal, an error and safety check that ensures proper decoding, and a data distributor that sends the decoded electrical-stimulation parameters to the programmable current source by switching the multiplexers on and off. The backward pathway includes a back-telemetry voltage sampler that reads the voltage for a time on the recording electrode. The PGA (programmable-gain amplifier) then amplifies voltage, the ADC converts it to the digital domain and stores it in memory, and the back-telemetry technology sends it to the external unit. The ASIC also has many control units, which range from the RF signal generated from the clock to the command decoder. The ASIC cannot easily integrate some functions, such as the voltage regulator, the power generator, the coil and RF-tuning tank, and the back-telemetry data modulator, but advances are occurring in these areas.

The current-source circuit, comprising a DAC and current mirrors, generates the stimulating current according to the amplitude information from the data decoder. This current source must be accurate and involves challenges. For example, due to process variations, the relationship between the source and the drain of the MOSFET is not constant, yet the voltage difference between the gate and the source controls the amount of current in the drain. For this reason, the circuit requires a trimmer network to fine-tune the reference current. New designs combine multiple DACs to obtain the desired accurate current, thereby eliminating the need for a trimmer. An ideal current source also has infinite impedance, so some designers use cascaded current mirrors at the expense of reduced voltage compliance and increased power dissipation.

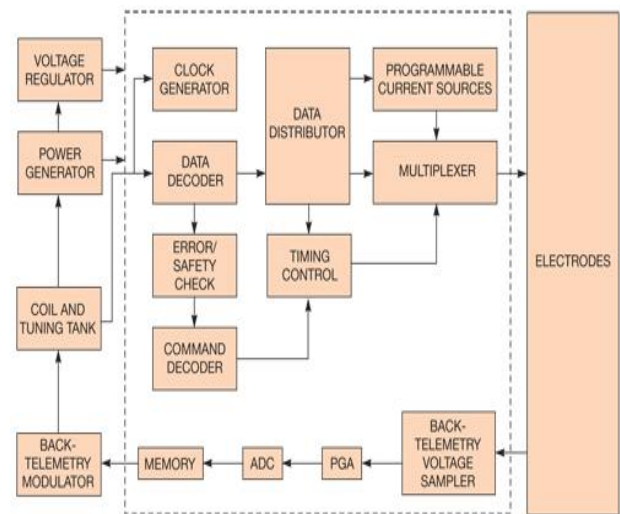

Fig5: A Receiver and a Simulator In An Internal Unit Act As The Engine Of A Cochlear Implant

You must carefully consider and implement these compromises. Some cochlear-implant products have multiple current sources, and older devices required a switching network to connect one current source to multiple electrodes. Recent designs use multiple current sources sequentially or simultaneously, however. In these designs, both the P- and the N-channel current sources generate positive and negative phases of stimulation. The challenge is to match the P- and the N-channel current sources to ensure balancing of the positive and the negative charges. Adaptive compliance voltages can reduce power consumption and maintain high impedance.

Engineers prefer ASK (amplitude-shift-keying) modulation over FSK (frequency-shift-keying) modulation because of ASK's simple implementation scheme and low power consumption with the high-frequency RF signal. Thanks to persistent and collaborative work by teams of engineers, scientists, physicians, and entrepreneurs, safe and charge-balanced stimulation has restored hearing to more than 120,000 people worldwide. These prostheses serve as models to guide development of other neural prostheses to improve the quality of life for millions of people.

VI. SIMULATION RESULT ANALYSIS

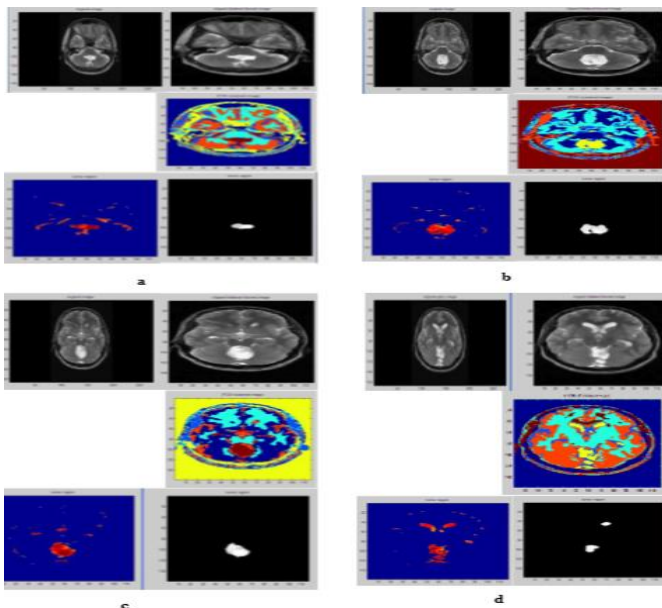

Fig6: C-MEANS CLUSTERING LEFT TO RIGHT

1st line original image & original image after cutting background and smoothing ; 2nd line , K-means clustering based on intensity and position of the background cutting and smoothing image & tumor cluster image ; 3rd line ,extracted tumor image after applying morphological operation on the tumor cluster image . a ,b , c & d for 5T2 ,6T2 ,7T2 & 8T2 images respectively.

1st line, original image & original image after cutting background and smoothing; 2nd line , mat-to-gray of the background cutting and smoothed image & contrast adjusted image; 3rd line, extracted tumor image & contour of tumor region. a ,b , c & d for 5T2, 6T2, 7T2 & 8T2 images respectively.

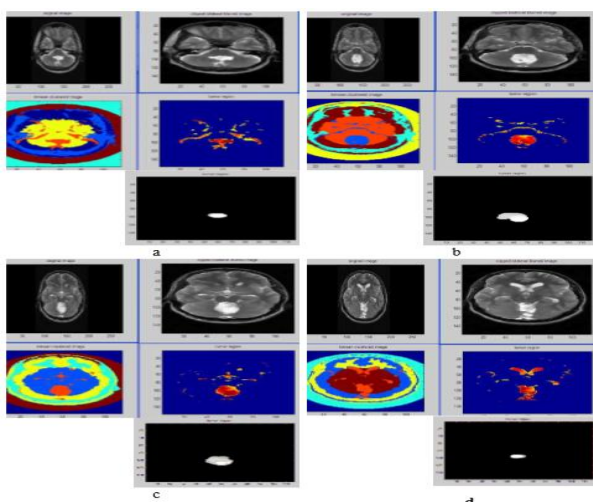

Fig7: CLUSTERING BASED ON INTENSITY AND LOCATION, LEFT TO RIGHT

VII. CONCLUSION

Despite the growing significance of technologies in the healthcare supply chains, little systematic understanding exists on the integration of technologies, the selection or performance implications of technology integration. Managers are keen on learning what technologies to invest in, how to select the appropriate level of integration, and what performance implications may be expected of the technology selection and integration. This study makes an effort towards addressing these issues. It makes a three-fold contribution in this area.

First, we conceptualize technology integration by way of a classification scheme of levels of technology integration comprising of various clinical technological applications employed in healthcare supply chains. While focused on healthcare supply chains, the proposed conceptualization may be extended, more generally, to services supply chains. **Second**, we account for self-selection of organizations into different levels of technology integration. In our research, we show that there is systematic self-selection into technology integration levels: while the conventional wisdom is that higher levels of technology integration translate into superior performance, we find that managers choose the level of technology integration based on observable and unobservable factors. **Third**, we demonstrate the link between levels of technology integration and operational performance based on an econometric analysis of data from approximately 1011 healthcare providers. From the standpoint of managerial practice, the paper sheds light into how technology integration affects operational performance and highlights the role of selection into technology integration levels. Also, this study which investigates technology integration in healthcare supply chains can provide new explanations on the inconsistencies in the extant literature of the actual benefits of IT investments, referred to as the 'productivity paradox.'

REFERENCES

[1] J. Ferlay, H. Shin, F. Bray, D. Forman, C. Mathers, and D. Parkin, "GLOBOCAN 2008, cancer incidence and mortality worldwide: IARC Cancer Base no. 10," International Agency for Research on Cancer,2010.

[2] J. Greenleaf and R. Bahn, "Clinical imaging with transmissive ultrasonic computerized tomography," Biomedical Engineering, IEEE Transactionson, vol. BME-28, no. 2, pp. 177-185, 1981.

[3] T. Hopp, A. Stromboni, N. Duric, and N. Ruiters, "Evaluation of breast tissue characterization by ultrasound computer tomography using 2D/3D image registration with mammograms," Proc. IEEE International Ultrasonics Symposium, 2013.

[4] N. Duric, P. Littrup, P. Chandiwala-Mody, C. Li, S. Schmidt, L. Myc, O. Rama, L. Bey-Knight, J. Lupinacci, B. Ranger, A. Szczepanski, and E. West, "In-vivo imaging results with ultrasound tomography: Report on an ongoing study at the Karmanos Cancer Institute," in Proc. SPIE, vol. 7629, 2010, pp. 76 290M–76 290M–9.

[5] J. Wiskin, D. Borup, S. Johnson, M. Berggren, D. Robinson, J. Smith, J. Chen, Y. Parisky, and J. Klock, "Inverse scattering and refraction corrected reflection for breast cancer imaging," in Proc. SPIE, vol. 7629, 2010, pp. 76 290K–76 290K–12.

[6] S. J. Norton and M. Linzer, "Ultrasonic reflectivity imaging in three dimensions: Reconstruction with spherical transducer arrays," Ultrasonic Imaging, vol. 1, no. 3, pp. 210 – 231, 1979.

[7] N. V. Ruiters, G. Gbel, L. Berger, M. Zapf, and H. Gemmeke, "Realization of an optimized 3D USCT," in Proc. SPIE, vol. 7968, 2011, pp. 796 805–796 805–8.

[8] M. Birk, M. Balzer, N. V. Ruiters, and J. Becker, "Evaluation of performance and architectural efficiency of FPGAs and GPUs in the 40 and 28 nm generations for algorithms in 3D ultrasound computer tomography," Computers and Electrical Engineering, no. 0, pp. –, 2013.

[9] M. Birk, M. Zapf, M. Balzer, N. Ruiters, and J. Becker, "A comprehensive comparison of GPU- and FPGA-based acceleration of reflection image reconstruction for 3D ultrasound computer tomography," Journal of Real-Time Image Processing, pp. 1–12, 2012.

[10] G. Schwarzenberg, M. Zapf, and N. Ruiters, "P3D-5 aperture optimization for 3D ultrasound computer tomography," in Ultrasonics Symposium, 2007. IEEE, 2007, pp. 1820–1823.

[11] H. Gemmeke, M. Kleifges, A. Kopmann, N. Kunka, A. Menchikov, and D. Tcherniakhovski, "First measurements with the AUGER fluorescence detector data acquisition system," International Cosmic Ray Conference, vol. 2, p. 769, 2001.

BIOGRAPHIES



1. Mrs. Akila S., M.Sc., M.Phil Research Scholar, Department of Computer Science, D.K.M. College for Women (Autonomous), Vellore. TamilNadu. India.

2. Ms. Siva sankari A., HOD, Department of Computer Science, D.K.M. College for Women (Autonomous), Vellore, TamilNadu, India.

3. Mrs. Lakshmi R., Asst. Prof Department of Computer Science, D.K.M. College for Women (Autonomous), Vellore, TamilNadu, India.