

DIESEL AND BLAST FURNACE GAS FIRED BOILER OPERATION AND MAINTENANCE

Mr. Shakti Prasad Dash¹, Mr. Soumya Ranjan Mohanty²

¹Executive Engineer (O & M), Blast Furnace Blower Section, Jindal Saw Ltd., Samaghogha, Kucchh, Gujarat - 370415

²Executive Engineer (O & M), Blast Furnace Blower Section, Jindal Saw Ltd., Samaghogha, Kucchh, Gujarat - 370415,

Abstract: The changes of flow rate and heating value of blast furnace gas (BFG) make the boiler operation more like art than science. In this paper the importance of operation and maintenance and the effect on the efficiency of boiler is discussed. For this we are considering a case study of a 16 TPH boiler capable of generating steam of 42Kg/Cm² and temperature 420±5°C. A system for automatic closed-loop control of drum boiler heat load for combined joint and separate combustion of blast-furnace gas and diesel oil under the conditions of randomly changed flow rates of blast-furnace and diesel is considered.

Key Words: Blast Furnace Gas, Boiler, efficiency, etc.

1. INTRODUCTION:

Steam generation system or boiler is used for changing the state of water i.e. from water to steam using thermal energy produced from various methods. For producing thermal energy a combustion system with a fuel and firing system is required. Firing system varies depending upon the fuel availability. From requirement point of view, both kinds of steam can be generated from boilers; saturated steam required for process heating purpose and superheated steam for the generation of shaft power. For both purpose in an industry a PRDS (Pressure Reduced De-Super heater) system is installed to generate a low pressure and low temp steam. It can also fulfilled by installing a back pressure turbine to generate power. Here in this case study Diesel Oil & CO gas is used as fuel to the boiler. For Blast Furnace, CO gas is the major by-product. In such cases dual fuel fired boiler is more effective from economic and environment point of view.

2. WORKING PRINCIPLE OF OIL & BF GAS FIRED WATER TUBE BOILER:

The working principle of water tube boiler is very interesting and simple. It consists of mainly two drums, one is upper drum called steam drum other is lower drum called mud drum. These upper drum and lower drum are connected with two tubes namely down-comer and riser tubes as shown

in the picture. Water in the lower drum and in the riser connected to it, is heated and steam is produced in them which comes to the upper drums naturally. In the upper drum the steam is separated from water naturally and stored above the water surface. The colder water is fed from feed water inlet at upper drum and as this water is heavier than the hotter water of lower drum and that in the riser, the colder water push the hotter water upwards through the riser. So there is one convectional flow of water in the boiler system.

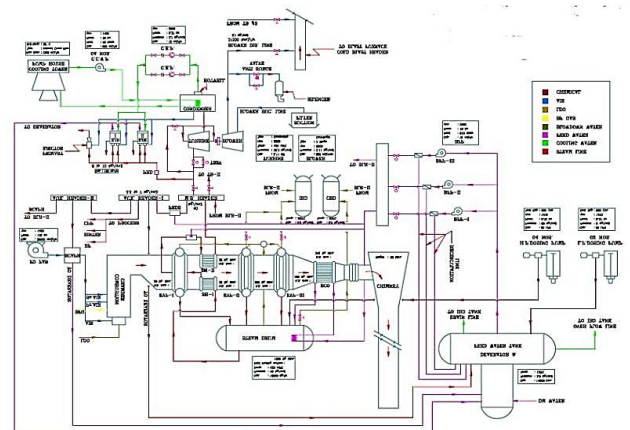

Fig No. 01 Boiler Process Layout

3. SEQUENTIAL FLOW OF WATER AND STEAM INSIDE BOILER EQUIPMENT:

3.1 Feed Water System before Boiler

Water from DM water Transfer Pump Outlet Header is taken to Feed Water storage tank, which is located near the boiler over the boiler control room. The feed water tank is provided with a level control system by which the level is maintained constant. The level control system comprises a level transmitter, Control valve, and its isolation & bypass valves. The status on % opening of the feed control valve is available in DCS through the position transmitter. The bypass valves of the feed control valve are normally in closed condition. The feed water tank is provided with a level switch, for raising alarm on low water level in the feed water tank. The signal is also used for tripping the boiler feed pumps on

low water level in the feed water tank. The feed water tank is provided with two level gauges for indication of water level in the tank. The feed water tank is complete with a drain valve & overflow line.

An LP Dosing system is provided to boost pH of DM water from 7 to 8.5 before feeding the water to the feed water tank. Further any other chemical required for sludge promotion in boiler is also dosed through the LP dosing system. The LP dosing system has 2×100% reciprocating dosing pumps. The LP dosing system is provided with a motorized stirrer for dissolving the chemical thoroughly before dosing the same in the boiler. The dosing tank is provided with a level switch, wired suitably to raise an alarm on exhaustion of chemical in the tank.

3.2 Feed water system from within the boiler:

From feed water storage Tank, feed water is feed to drum by 2×100% boiler feed water pump (1 working+1 stand by). A three element drum level control system comprising feed flow transmitter, pneumatically operated control valve, steam drum level transmitter, steam flow transmitter, is provided for maintaining a constant water level in the steam drum. The control logic is incorporated in DCS. The status on % opening of the feed control valve is indicated in the DCS. The feed control valve is provided with necessary isolation valves and bypass valves. The feed line pressure is displayed in the DCS through the signal generated from pressure transmitter located in the feed line. Each feed pump is provided with pressure gauges for local indication of feed pump discharge pressure.



Fig No. 2 Feed Water Pump



Fig No. 3 De-aerator & FW Storage

A minimum bypass arrangement is provided in the feed pump discharge line to bypass the minimum quantity of water from the feed pump. The arrangement includes a solenoid energized pneumatically operated bypass valve. In the event of raise of pump discharge pressure, which is due to partial or full closure of the feed control valve, or the closure of the feed pump delivery valves, the bypass valve opens. The command for open/close is generated by the DDCMIS in the event the feed water flow drops below the minimum flow permitted.

3.3 Boiler Evaporation System

The feed water is fed into the steam drum to the down comer section by means of feed water distributor. The water passes to the bottom drum through a section of convection bank tubes, acting as down comers. The water rises through the furnace side tubes & Boiler bank tubes to the steam drum. The heat transferred from the flue gas exchanges the heat to the water inside the tubes. The circulation is established through the furnace tubes and convection bank tubes on siphon principle.

The boiler steam drum is provided with two nos. safety valves, One nr Pressure gauge, One air vent valve, two no's direct water level gauges. An auto water level controller is provided to generate signal in the event of low water level. This signal is used for alarm as well as tripping of the boiler. The steam drum is provided with a continuous blow down arrangement, which is manually set depending on the recommended boiler water quality.

The mud drum is provided with provided with a motorized blow down valve and necessary bypass valves. This is operable from DCS or the local control panel through the use of push buttons for open/close. The motorized blow down valve is provided with position switches for feedback on 100% open and 100% close positions & torque limit switches for motor protection. The blow down lines from motorized blow down valve & continuous blow down valve are connected to neutralizing pit. The boiler is provided with suitable casing to prevent leakage of flue gas. The casings are adequately insulated to prevent heat loss and for human safety. The steam drum is provided with two stage chevron separators for separating the moisture from steam. The dry steam passes through the super heater coils to be heated to necessary degree of superheat.

3.4 Super heater system

The saturated steam from drum is passed through the super heater to obtain necessary degree of super heater. The super heater coils are arranged horizontally so that the super heater is completely drainable. The super heater assembly is provided with necessary vents and drains. The boiler is provided with a spray type de-super heater for the steam temp control, comprising spray control valve, Temperature element. The temp control

action is carried out by control system. The steam line is provided with a pneumatically operated vent valve to vent the steam in the event of steam demand variation. The valve is operated through manual loader in local panel or through the remote panel.

A safety valve is provided for restricting the boiler pressure to normal operating pressure. Pressure gauge, vent valve, steam trap as required for regular operation of the boiler is provided.

A steam flow orifice meter along with flow transmitter is provided in the steam line for measurement of steam flow and for three element drum level control. Sample coolers are provided for sampling the feed water, boiler water, saturated steam, superheated steam. All the sampling lines are laid to a sample cooler station for taking samples.

4. FUEL OIL HANDLING SYSTEM

Oil for main oil storage tank is taken in oil header by two nos. LDO pressurizing pumps LOP 15172 & LOP15173 (1 working + 1 standby). Two nos. oil filters LOF01 & LOF 02 are provided on the suction side of the pumps.

The oil pressure in the oil header is regulated by the back pressure regulating valves. A pressure transmitter is provided for generating 4-20 ma signals for indication the pressure in the boiler control & control panel. In the event of low oil pressure the alarm signal is generated for raising alarms in local boiler control panel. Each of the pumps is provided with pressure gauges for local indication. At the discharge of the oil transfer pumps pressure switches are provided for generating open/close contacts in the event of low pressure. These signals are used for starting the standby LDO pressurizing pump instantaneously, when the oil discharge pressure in the working pump drops due to any reason.

An oil flow element along with flow transmitter is provided for indicating the oil flow rate. The same is also used in control panel for indicating, recording and controlling the oil flow rate according to steam demand.

4.1 Fuel oil pumping system

The LDO is pumped to the burner nozzle by means of (2×100%) two fuel oil flow rate pumps LOP 15172 & LOP 15173. Fine filter are provided in the oil line for filter foreign material which are likely to choke the fuel oil spray nozzle.

The LDO line is provided with high pressure switch, low oil pressure switch, pressure transmitter for indicating the oil pressure & for implementing burner safety interlocks as explained in burner startup & control philosophy. Alarm signals are generated from control panel in the event of low/high oil pressure.

The oil flow to burner is controlled using oil flow control valve, the % opening of which is done by the combustion control logic programmed in the control panel.

Return oil piping with a back pressure regulating valve, is provided in the oil line for recirculating the oil during the idling of oil pump. The SSOV15181 is oil shut off valve designed to close the oil flow to the burner nozzle during the burner tripping SSOV12184 is an air-purging valve provided to keep the burner nozzles clean during the burner tripping/shutting down. This ensures no oil is left over in burner oil piping or burner nozzle.

4.2 Burner atomizing system

The oil spraying from the burner nozzle is assisted by the force provided by the pressure of atomizing air. The atomizing air is drawn from the air receiver through the pressure regulating valve. The pressure switch is provided in the atomizing line to generate signal in the event the air pressure falls below the required minimum pressure. The burner is tripped in the event of low pressure of the atomizing air. Atomizing air is shut off to the burner when the burner is tripped. For this purpose, SSOV12184 is provided. SSOV12184, 12185 & 15181 are all solenoid energized pneumatically operated valves. Strainers are provided both in oil line and airline to prevent any dirt blockage in the nozzle.

4.3 Flue gas system

The flue gas produced travels through the furnace enclosure formed by the sidewall tubes on the left side & tangent bank tubes on the right side. The gas takes a 'U' turn to Super heater bank & then pass through the convection bank tubes. The gas leaving the bank tubes is discharged through the chimney to atmosphere.

The furnace chamber is provided with a draft gauge, Draft transmitter for furnace draft indication in local panel and remote panel respectively. Thermocouples are provided to measure the temperatures before super heater, after super heater and after boiler. These temperature indications are available in control panel.

5. COMBUSTION AIR SYSTEM

The FD fan CAF24122 Is provided to supply the combustion air required for combustion. In addition part of the CA system is used for cooling the scanners. The combustion air to the burner is regulated by the discharge damper operated by a servomotor. Two nos. position limit switches are provided to generate signals for damper 100% close condition and for 30% open condition. The signal to operate the servomotor is generated by the main stream pressure controller. A draft gauge and a draft transmitter are provided in the air line for local indication & remote indication of combustion air pressure. A pressure switch is provided in the air line for generating signal in the event of low air

pressure. In the event of low air pressure alarm & trips are initiated. Similarly if the pressure is low the burner would not start at all.

5.1 Scanner & scanner cooling system

Two no. of scanners are available for sensing the flame. The signals from the scanners are processed in signal processors and the signals from signal processors are used for necessary safety interlocks in the burner management system. The cooling air for the scanner is taken from atomizing air receiver. Hence the scanner cooling air is tapped before the discharge damper. To protect the scanner against damage in the absence of non-availability of cooling air, pressure switch generates signal. This signal is used for tripping the burner.

6. BOILER OPERATION AND LOAD CONTROL

The burner management logics put the burner on minimum firing position as explained above. Further firing rate has to be manually raised as per the permissible boiler pressurizing rate. The pressure building in the boiler can be done either from the local panel or from the remote panel. The pressure is raised from the local panel through manual loader.

6.1 Boiler drum water level Control

The boiler water level control can be done from local panel by means of manual loader provided for feed control valve. The local/remote option will be selected from boiler control panel. The water level indication is available in the local control panel. The feed regulation can be done from the control panel in the remote manual mode. While on auto, three-element loop control, would take over the feed water regulation. Auto mode selection is to be done only after the plant running is stabilized. The reason is that the steam flow signal is being used for three element level control. The three-element control responds to variation in steam demand immediately.

Under any circumstance, if the feed water flow comes below the preset value. The minimum flow (solenoid energized pneumatically actuated) valve LV31003 is actuated. This safeguards the boiler feed pump against failures due to no flow.



Fig. No.4 Boiler Steam Drum

6.2 Super heater temperature control

The boiler Feed water tank level control can be done from local panel by means of manual loader provided for feed water tank control valve. The local/remote option will be decided from boiler control panel. The water level indication is available in the boiler control panel. The water flow regulation can be done from the remote panel in the remote manual mode. While on auto, single-element loop control would take over the feed water tank level regulation through the level controller.

The level signal transmitted by level transmitter LT31001 located on Feed Water Tank is used for Level Control.

6.3 LP dosing control

The Boiler feed water is transferred by the transfer pump to the feed water tank. The pH of the water is the range of 6.5 to 7. The pH is to be boosted to 8.5 to 9.5 in the feed water tank. Morpholine shall be used for raising the pH. The dosing rate is set by testing the water for pH. Dosing chemical such as tri-sodium phosphate/Hexa met-phosphate is to be fed in the boiler for removal of residual hardness. The required residual PO₄ level shall be maintained in the boiler water. The dosing rate is established by trial adjustment.

6.4 Blow down control

The TDS in the boiler water is to set below the recommended limit. This can be established by adjusting the continuous blow down valve CBD1286. The intermittent motorized blow down valve IBV, is operated only for draining/ emergency draining of the water from the boiler.

6.5 Vent Control

The vent control valve can be operated locally by rotating the hand wheel or electrically by keeping the selector switch in manual mode. Also can be operated from remote area through DCS by keeping the selector switch in remote mode. This selector switch is available on the valve actuator. It can be operated as necessary, at the time of starting the boiler and also at the time of running for controlling the steam pressure.

7. CONCLUSION: The energy contained in the Blast furnace Gas (CO majority) having a calorific value 670 Kcal/Kg can be utilized by burning it in a dual fuel fired boiler to produce steam for Power generation as well as process heating purpose. Proper operation of the boiler increases the efficiency of the steam generation system. As the CO gas contain some fly ash after filtration, so it is very much necessary to maintain the boiler along with its components and accessories in proper condition, so that it will give its maximum output.

REFERENCES:

- [1] R. B. Akhmedov and L. M. Tsirul'nikov, *Combustible Gas and Liquid Fuel Combustion Technology* (Leningrad, Nedra, 1984) [in Russian].
- [2] V. Sh. Magadeev, *Corrosion of the Boiler Unit Gas Path* (Energoatomizdat, Moscow, 1986) [in Russian].
- [3] S. V. Altyn and S. I. Vinogradov, "About achieving more accurate control of fuel flow rate in gas-and-oil-fired boilers," *Energetik*, No. 7, 4-5 (1984).
- [4] R. A. Aliev, *Industrial Invariant Automatic Control Systems* (Energiya, Moscow, 1971) [in Russian].
- [5] S. K. Ismatkhodzhaev and M. Takhirdzhanov, "Automatic closed-loop control of boiler unit heat load during joint combustion of blast-furnace, coke, and natural gases," *Prom. Energ.*, No. 9, 40-42 (1979).
25-30 (1970).
- [6] V. D. Mironov, "About the dynamic properties of drum boilers in terms of steam pressures and flow rates," *Teploenergetika*, No. 4, 14-22 (1955).
- [7] G. M. Rublev and G. D. Garnits, "Automatic closedloop heat load control in a boiler simultaneously firing a few kinds of fuel," *Prom. Energ.*, No. 6, 30-31 (1975).
- [8] V. V. Volgin, "Selecting the structure and parameters of compensation devices used in industrial combined control systems operating under the conditions of low-frequency disturbances," *Prom. Energ.*, No. 1, 5-7 (1966).
- [9] V. S. Balakirev, E. G. Dudnikov, and A. M. Tsirlin, *Experimental Determination of the Dynamic Characteristics of Industrial Controlled Plants* (Energiya, Moscow, 1967) [in Russian].
- [10] V. V. Volgin, R. I. Karimov, and A. S. Koretskii, "Consideration of real disturbing effects and selection of quality criteria in comparative assessments of thermal process control quality," *Teploenergetika*,

BIOGRAPHIES:



Mr. Shakti Prasad Dash, currently working as an Executive Engineer in Boiler O&M section of Blast Furnace in Jindal SAW Ltd., Gujarat. He has completed his B. Tech in Mechanical Engineering from Gandhi Institute of Engineering & Technology, Gunupur. He also have published many papers in different International Journals and Conferences.



Mr. Soumya Ranjan Mohanty, currently working as an Executive Engineer in Boiler O&M section of Blast Furnace in Jindal SAW Ltd., Gujarat having 4 years of experience in Boiler Operation and Control. He has completed his B. Tech in Mechanical Engineering from Gandhi Institute of Engineering & Technology, Gunupur