

## Influence of Fibres on Crack Arrest Mechanism and Shear-Friction Behavior of Different Concrete Using Push-Off Specimen

Harish Kumar N R<sup>1</sup>, Pavankumar<sup>2</sup>, Dr. K P Nagaraja<sup>3</sup>, Dr. Prabhakara R<sup>4</sup>

<sup>1</sup> Research Scholar, Civil Engineering, M.S.Ramaiah Institute of Technology, Karnataka, India

<sup>2</sup> Research Scholar, Civil Engineering, M.S.Ramaiah Institute of Technology, Karnataka, India

<sup>3</sup> Professor, Civil Engineering, M.S.Ramaiah Institute of Technology, Karnataka, India

<sup>4</sup> Professor and Head, Civil Engineering, M.S.Ramaiah Institute of Technology, Karnataka, India

\*\*\*

**Abstract** - This paper demonstrates the results of an experimental investigation conducted to study the direct shear transfer capacity of Normal Strength Concrete (NSC), Self-Compacting Concrete (SCC) and High Strength Concrete (HSC) by conducting a recently developed push off specimen. Generally shear is critical in reinforced concrete elements such as corbels, bearing shoes, ledger beam and host of connection between precast concrete elements. Therefore shear transfer across a specific plane needs special consideration. All these elements may fail in direct shear, which may be sudden or brittle (without any warning). An experimental investigation on the influence of addition of fibre on crack arrest mechanism and shear friction behavior is considered in the present studies. Size of the Push-off Specimen chosen was 150mm × 150mm × 260mm, notches of 10mm thick and 150mm length were cut perpendicular to the loading axis on the specimen. The end blocks of the Push Off specimens were strengthened with a mesh of 5mm diameter TORKARI bars of grade Fe 550. Total of 90 push-off specimens were prepared using normal strength concrete (NSC-30), high strength concrete (HSC-70), and self-compacting concrete (SCC-30). The crack width and ultimate shear stresses in the above concrete are determined under laboratory conditions. The steel fibres are added at 0.5%, 1% and 1.5% of volume of push-off specimens, Glass and polypropylene fibres are added on weight basis at 1%, 1.5% and 2% in case of glass fibres where as 0.15%, 0.3% and 0.45% were used for polypropylene fibres. The formation of cracks under the applied loads and the corresponding shear stresses are evaluated and presented in the report. An attempt is made to predict the shear stresses by developing a mathematical model using the experimental data.

**Key Words:** Shear stress, Shear transfer, fibres, NSC, SCC, HSC.

### 1. Introduction

Concrete is a multiphase granular material consisting of aggregate particles of various sizes and shape, embedded in hardened cement paste. Engineering properties like compression, flexure, and torsion are considered to be important. Shear failure in reinforced concrete structures is one of the most undesirable modes of failure due to its rapid progression. This sudden type of failure made it necessary to explore more effective ways to design shear keys, web flange stress transfer, brackets in column, corbel, ledger beams, punching resistance, coupled shear walls, wall to foundation connections and cast-in-place concrete toppings for shear [4]. Shear is a force that tends to produce sliding failure of concrete along the plane that is parallel to the direction of applied force. In the precast concrete structures in-plane shear is also an important criterion to be considered. Changes in different grades of concrete changes the mechanical and fracture properties, therefore fundamental knowledge of in-plane shear strength which is essential for ductility or toughness parameter in structural design. However from literatures it is well known that shear failure of concrete is brittle, for introduction of ductility or toughness parameter in relevant structural design knowledge of shear failure is essential. The shear strength in depends on the factors like concrete strength, aggregate interlock[2].

Fibre reinforced concrete (FRC) is Portland cement concrete reinforced with randomly distributed fibres. In FRC, thousands of small fibres are dispersed randomly in the concrete during mixing, in order to improve concrete properties.

FRC is cement-based composite material that has been developed in recent years. It has been successfully used in construction with its excellent flexural-tensile strength, resistance to splitting, impact resistance and excellent permeability and frost resistance. It is an effective way to increase toughness, shock resistance and resistance to plastic shrinkage cracking of the mortar. Fibre are a small piece of reinforcing material possessing certain characteristics properties. They can be circular, triangular

or flat in cross-section. The addition of steel fibers to the concrete mixture improves the tensile behavior and ductility, in addition to good crack control. Also, steel fibers improve the shear behavior of structural elements increasing their shear load capacity, and ductility. Therefore, with the use of fibres it is possible to reduce deformation, increase ductility and the ultimate capacity of connections.

**2. objects of present investigation:**

- To arrive at the mix proportion for M30 NSC, M30 SCC and M70 HSC.
- To compare the in plane shear stress developed in different grades of concrete under consideration.
- To study the variation in shear stress and crack width for different concrete used.
- Shear stresses are computed analytically by using Regression analysis model. comparison between experimental and calculated values are made and presented.

**3. Materials and Mix Proportions:**

The following materials were used in the present investigation.

**Cement:** 53 Grade OPC as per IS 12269- 1989 with specific gravity 3.15. **Fly Ash:** Fly Ash conforming to ClassF IS 3812:2003. **Coarse Aggregates:** 20mm downsize Aggregates with specific gravity 2.65 for NSC. 12.5mm down size aggregates with specific gravity 2.62 for SCC & HSC. Coarse aggregates were conforming IS 383:1970. **Fine Aggregates:** Manufactured Sand with specific gravity 2.57 and Fineness Modulus 3.05 conforming to zone II of IS 383:1970. **Super Plasticizers:** Naphthalene based polymer (Conplast SP 430) complying with IS: 9103:1999 for HSC. Glenium B233 Modified poly-carboxylic ether for SCC. **Viscosity Modifying Agent:** Glenium Stream 2 for SCC. **Steel:** 5mm diameter TORKARI bars for strengthening of end blocks of Push Off Specimen. **Water:** Potable water conforming to IS 456:2000.

**Mix Proportions:**

Mix design adopted during the present investigations are as follows: **NSC** M-30 as per IS 10262:2009; **SCC** M-30 NAN-SU (Chinese) method. **HSC** M-70 design procedure given by R. Prabhkara et al. The final mix proportion are presented in table 1

Table 1. Mix proportions of NSC, SCC and HSC

	NSC	SCC	HSC
Cement (kg/m <sup>3</sup> )	348.33	214.28	500
Fly Ash (kg/m <sup>3</sup> )	-	248.43	-
Fine Aggregates (kg/m <sup>3</sup> )	681.66	925.63	666.01
Coarse Aggregates (kg/m <sup>3</sup> )	1146.8	743.69	1000
Water (lit/m <sup>3</sup> )	191.58	148.07	150
Super Plasticizer	-	1.3%	2.5%
VMA	-	0.18%	

**4. Experimental Investigation:**

Based on the literature review three types of push-off specimens were prepared with different types fibres i.e, polypropylene fibres, Glass fibres and Steel fibres with different dosages. The dosage of fibres varied are 0.15%, 0.3% and 0.45% by weight of cement for polypropylene fibres, 1%, 1.5% and 2% by weight of cement for Glass fibres and 0.5%, 1%, 1.5% by volume of concrete for Steel fibres.

The specimens were prepared using moulds of 150x150x260mm. The end block of the specimens were reinforced with cage reinforcement of 5mmφ bars (TORKARI) of **Fe500** as shown in the figure 1

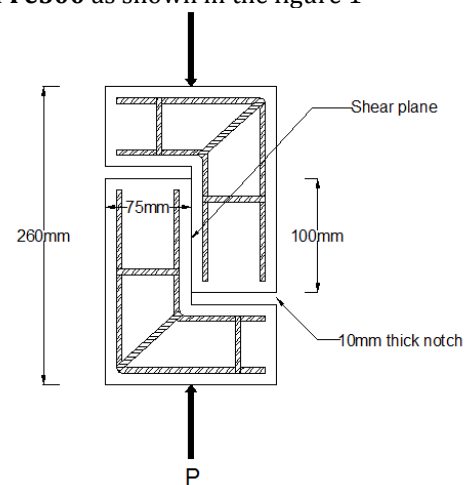

Figure 1 schematic diagram of push-off specimen with cage reinforcement

A total of 90 push-off specimens were casted using different category of concretes such as NSC (M30), SCC (M30) and HSC (M70) that is 27 push-off specimens in each type of concrete and 9 control specimens.

**5. Results and Discussions:**

The results of cube compressive strength of different grades of concretes after trail mixes used to caste push-off specimens is as given in Table 6.1.

**Table 2:** Cube Compressive Strength for trial mixes.

Concrete type	Grade of concrete	Cube size,mm <sup>2</sup>	Cube compressive strength, $f_{ck}$ (MPa)	
			7days	28days
NSC	M30	150×150	24.12	38.73
SCC	M30	150×150	25	44.47
HSC	M70	100×100	54.93	71.16

Concrete strength, percentage of fibre reinforcement and width of crack are the important variables considered in the present investigation. In case of the plane push-off specimens the fractured surface was found to be transgranular (passing through aggregate) in HSC and cracks were found to be surface-granular (passing over the surface of the aggregates) in case of NSC and SCC. Fractured surface of failed push-off specimens are shown in Figure 2

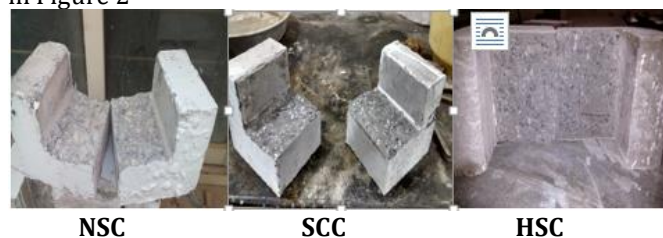

**Figure 5.1:** Cracked surfaces of failed push-off specimens

The cracks were observed along the shear plane of the push-off specimen. Cracks were initiated from one of the notch tip and propagated towards the other notch tip. Few specimen failed within the endblocks. In case of fibre reinforced push-off specimen, the crack width were observed to be less compared to plane push-off specimen. Fibres reinforced push-off specimen are observed failing in ductile manner. The failure pattern in fibre reinforced push-off specimen is shown in the Figure 3(a), (3b) and 3(c) respectively for steel, Glass and polypropylene fibres.



**Figure 3(a):** Failure pattern in Steel fibres reinforced push-off specimens



**Figure 3(b):** Failure pattern in Glass fibres reinforced push-off specimens



**Figure 3(c)** Failure pattern in Polypropylene fibres reinforced push-off specimens

The push-off specimens which have steel fibres failed after the formation of vertical cracks and specimens did not split, because of the dowel action of steel fibres which tend to hold the specimens together showing Ductile failure (gradual failure) in NSC, SCC and HSC. In case of Glass and polypropylene fibres after the initial crack was observed the specimens failed in a brittle manner which results in splitting up of the specimen in NSC, SCC and HSC in Glass fibres and SCC and HSC in polypropylene fibres as observed in the above images.

The calculated and observed values from the experimental results are systematically presented in the form of table 3. **Table 3:** Test results of the Push Off Specimen

Concrete specimen type	$f_{ck}$ (Mpa)	$f'_c$ ( $0.8f_{ck}$ ) (MPa)	$\tau$ (Mpa)	Crack width (mm)
NSC/0	40	32	5.01	1.12
NSC/SF/0.5	42.95	34.36	5.99	0.35
NSC/SF/1.0	42.07	33.65	7.14	0.23
NSC/SF/1.0	44.04	35.23	7.19	0.15

5				
NSC/GF/1.0	43.6	34.88	6.43	0.5
NSC/GF/1.5	48.39	38.71	6.92	0.33
NSC/GF/2.0	46.65	37.32	6.16	0.47
NSC/PF/0.15	47.08	37.66	5.02	1.05
NSC/PF/0.30	47.96	38.36	5.29	0.25
NSC/PF/0.45	50.14	40.11	5.06	0.9
SCC/0	48.84	39.072	7.7	0.96
SCC/SF/0.5	42.42	33.93	8.72	0.97
SCC/SF/1.0	44.03	35.22	9.26	0.6
SCC/SF/1.5	44.47	35.57	9.59	0.53
SCC/GF/1.0	46.21	36.96	8.99	0.83
SCC/GF/1.5	45.78	36.62	8.88	0.71
SCC/GF/2.0	47.08	37.66	8.12	0.47
SCC/PF/0.15	48.83	39.06	8.22	1.16
SCC/PF/0.30	47.96	39.36	8.83	0.56
SCC/PF/0.45	46.65	37.32	8.88	0.73
HSC/0	68.24	54.59	8.55	0.74
HSC/SF/0.5	77.5	62	13.98	0.42
HSC/SF/1.0	78.48	62.78	16.02	0.26
HSC/SF/1.5	76.51	61.2	15.85	0.26
HSC/GF/1.0	81.52	65.21	13.4	1.03
HSC/GF/1.5	79.56	63.56	14.38	0.73
HSC/GF/2.0	82.4	65.92	13.98	1.56
HSC/PF/0.15	84.36	67.48	13.73	0.83
HSC/PF/0.30	82.4	65.92	14.24	0.56

HSC /PF/0.45	87.3	69.84	13.65	0.6
--------------	------	-------	-------	-----

From the above experimental results the plot of shear stress Vs percentage of Steel, Glass and polypropylene and crack width Vs percentage of fibres in the NSC, SCC and HSC are plotted as shown in the figure 5.3 and 5.4.

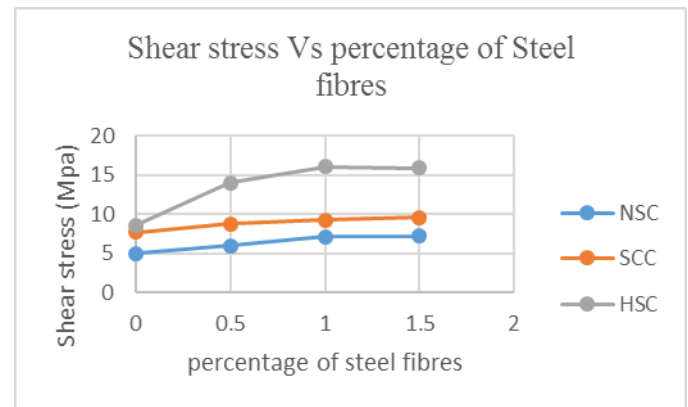

Fig 4(a) Shear stress Vs percentage of Steel fibres

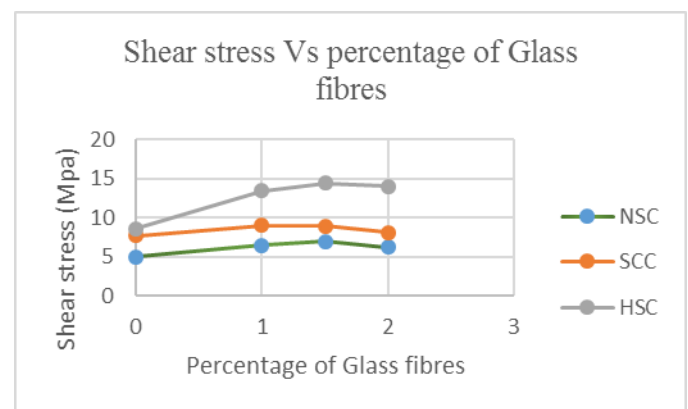

Fig 4(b) Shear stress VS percentage of Glass fibres

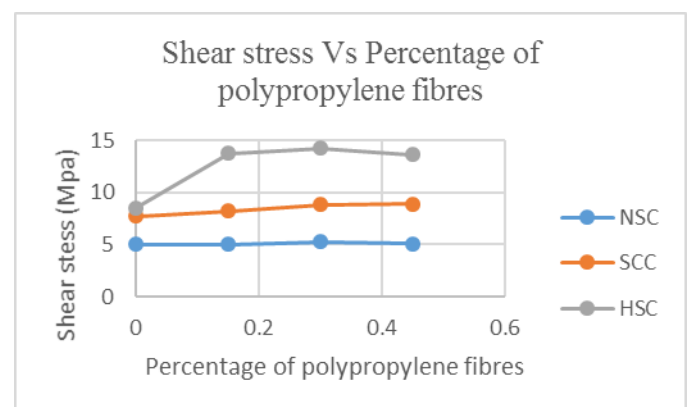

Fig 4(c) Shear stress Vs percentage of polypropylene fibres



The figures shows the shear stress Vs varying percentage of Steel, Glass and polypropylene fibres in Normal strength concrete, Self-compacting concrete and High strength concrete. From the fig 4(a) it can be seen that increasing the percentage of steel fibres increases the shear stress. In case of Glass and polypropylene fibres the shear stress increases with increase in the fibres content and this true upto 0.3% in polypropylene fibres and 1.5% in case of Glass fibres, further increase in the percentage of fibres decreases the shear stress as shown in the figure 4(b) and 4(c).

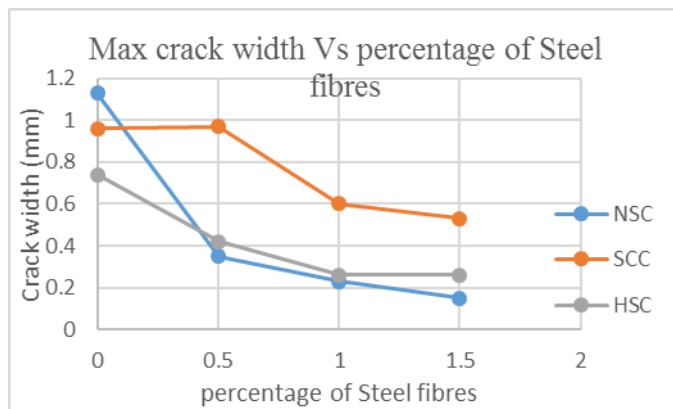

Fig 5(a) percentage of steel fibres Vs Crack width

In this case it can be observed that as percentage of steel fibres increases the crack width is decreasing. This shows that steel fibres have good crack arresting capacity. It can also be seen that steel fibres have better crack control in NSC and HSC over SCC.

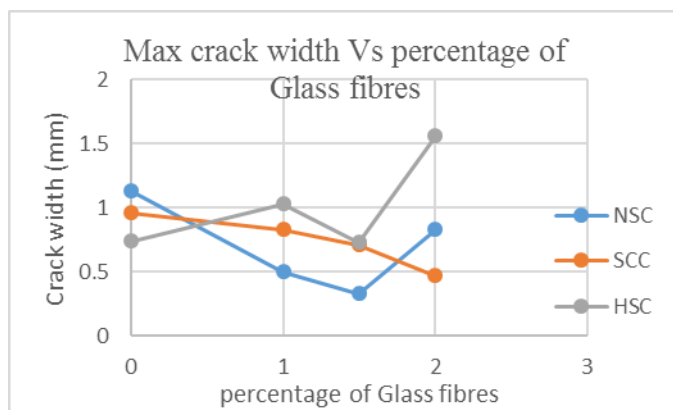

Fig 5(b) percentage of Glass fibres Vs Crack width

Here it can be seen that as the percentage of Glass fibres increased the crack width is decreased and this true upto 1.5% beyond that the control of Glass fibres over the crack arresting capacity is decreased.

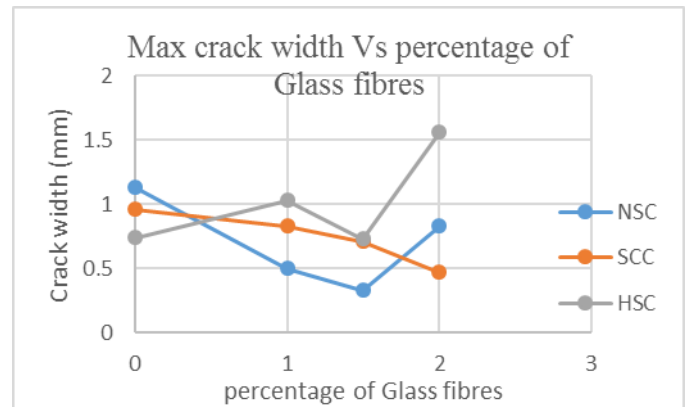

Fig 5(c) percentage of polypropylene fibres Vs Crack width

In this case it is similar to that of Glass fibres i.e, the crack arresting capacity of polypropylene fibres decreases beyond 0.3%.

The shear stress  $\tau_{cr}$  (at which first crack appear) Vs percentage of Steel, Glass and polypropylene in NSC, SCC and HSC are plotted as shown in the figure 5(a), 5(b) and 5(c).

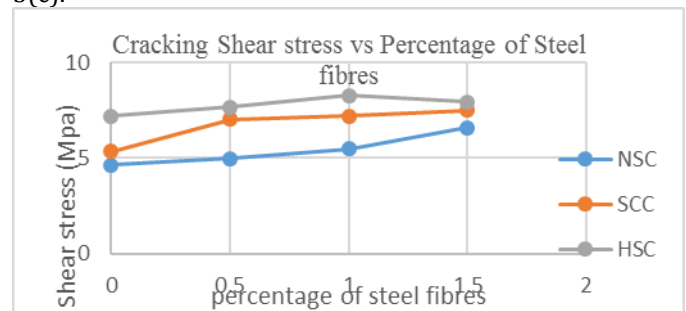

Fig 6(a) shear stress  $\tau_{cr}$  Vs percentage of Steel fibres

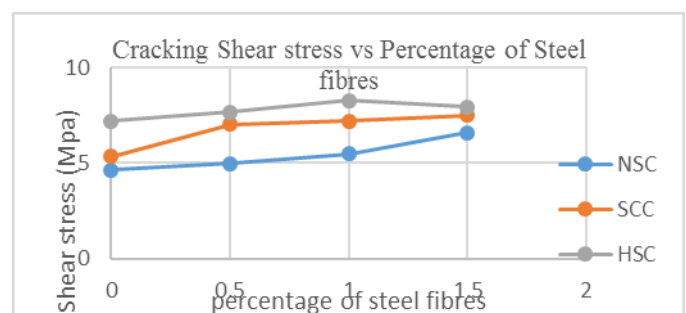
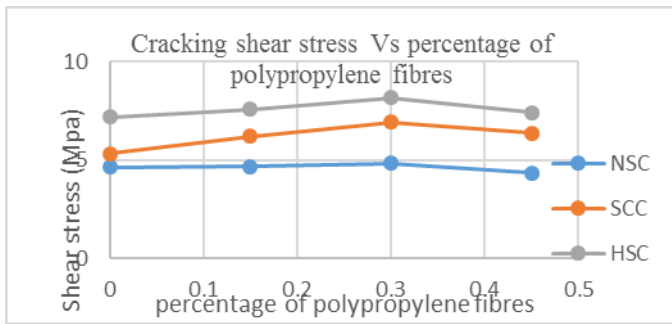

Fig 6(b) shear stress  $\tau_{cr}$  Vs percentage of Glass fibres



**Fig 6(c) shear stress  $\tau_{cr}$  Vs percentage of polypropylene fibres**

From the above plots it can be seen that increasing the dosage of fibres increases the cracking shear stress (shear stress at which first cracks appears), this true for Steel fibres but in case of glass and polypropylene fibres increasing the percentage of fibres beyond 1.5% and 0.3% cracking shear stress decreases.

An attempt is made to develop a regression equation of the type  $\tau = c x_1^a * x_2^b * x_3^c$  where a, b, c are coefficients,  $x_1, x_2, x_3$

Are independent variables (fibres content, compressive strength and crack width) and  $\tau$  is the shear stress.

The regression equation obtained are given below.

$$\tau_u = 0.123 * SF^{0.2608} * f_c^{1.248} * W_{cr}^{0.259} \text{ for steel fibres}$$

$$\tau_u = 0.44356 * GF^{-0.04547} * f_c^{0.827} * W_{cr}^{0.223} \text{ for Glass fibres}$$

$$\tau_u = 0.06348 * PF^{0.03983} * f_c^{1.2953} * W_{cr}^{0.07216} \text{ for Polypropylene fibres}$$

The calculated shear stresses from the above equations and the experimental shear stress are plotted as shown in the figure 7(a), 7(b) and 7(c)

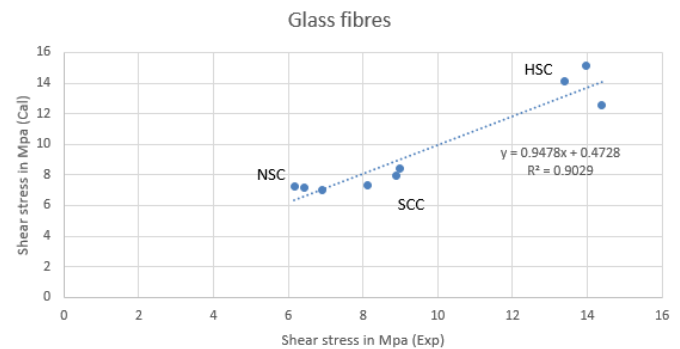

**Fig 7(b): Plot of calculated shear stress Vs Experimental shear stress for Glass fibres**

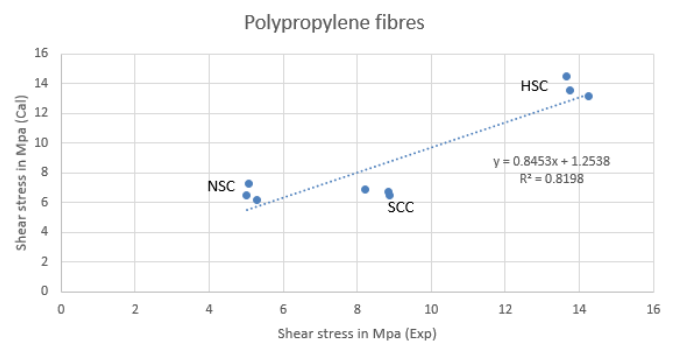

**Fig 7(c): Plot of calculated shear stress Vs Experimental shear stress for polypropylene fibres**

### ACKNOWLEDGEMENT

We acknowledge the support rendered by the Management of MSRIT, Principal, HOD, Faculty and staff of Civil Dept. In particular we express our deep sense of gratitude to Hiranyiah, Chief Engineer Bhagirath constructions for extending his help throughout the investigations.

### Conclusion:

- From the experiment it was clear that the shear stress was more and crack width was decreased when the fibres are added and this is because the pullout resistance and dowel action of fibres has led to considerable residual load carrying capacity in shear dominated failure. And all the specimen have failed in the shear dominated zone.
- Significant improvement in the ductility (gradual failure) of concrete during shear failure and increase in the shear strength were achieved through the incorporation of steel fibres in normal strength concrete, self-compacting concrete and high strength concrete.
- In case of glass fibres there was no improvement in the ductility, however the shear load carrying capacity of the push-off specimen was increased.
- Significant improvement in ductility (because the failure is gradual) of concrete during failure and increase in the shear strength were observed

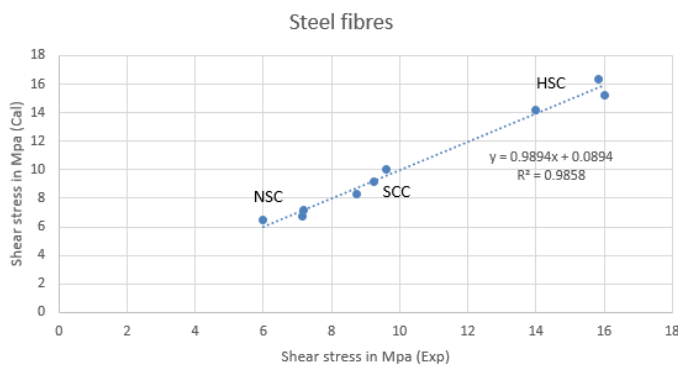

**Fig 7(a): Plot of calculated shear stress Vs Experimental shear stress for Steel fibres**

through addition of polypropylene fibres was seen only in NSC, whereas in case of HSC and SCC failure was in brittle (sudden failure) manner.

- However in the case polypropylene fibres load carrying capacity increases with addition of fibres this is true up to 0.3%. Beyond this shear stress decreases with increase in the fibres. Therefore optimum dosage of polypropylene fibres is 0.3% and case similar in Glass fibres Except that the load carrying capacity is more than the polypropylene fibres and in this case the optimum dosage can be taken as 1.5% considering the shear carrying capacity and crack arresting capacity.
- It was observed that crack arrest mechanism of steel fibre was better than glass fibres and polypropylene fibres. During the test it was found that steel fibres has greater crack control as demonstrated by crack width.
- The failure pattern was found to be trans-granular (passing through aggregate) in HSC and cracks were found to be surface-granular (passing over the surface of the aggregates) in case of NSC and SCC.
- The Predicted Equation from regression analysis is used to estimate shear stress values and these values are compared with experimental values. In case of Steel fibres Coefficient of Variation is 4.60%. The graph showed that COR ( $R^2$ ) was found to be 0.9852, showing linearly varying graph.
- In case of Glass fibres Coefficient of Variation is 10.77%. The graph showed that COR ( $R^2$ ) was found to be 0.9029, showing linearly varying graph.
- In case of polypropylene fibres Coefficient of Variation is 23.23%. The graph showed that COR ( $R^2$ ) was found to be 0.8198, showing linearly varying graph.

## REFERENCES

- [1] REFS.A.Saeed, S.R.Sarhat "Strength of Fiber Reinforced High-Strength Concrete With Stirrups Under Direct Shear" Journal of Zankoy Suloinani, 1999.
- [2] Javier Echegaray-Oviedo, Juan Navarro-Gregori, Estefania Cuenca And Pedro Serna "Upgrading The Push-Off Test To Study The Mechanisms Of Shear Transfer In Frc Elements" VIII International Conference on Fracture Mechanics of Concrete and Concrete Structures. pp 1-10
- [3] Tim James Ibell and Chris John Burgoyne " The shear strength of concrete containing fibre reinforced plastic (FRP) reinforcement".
- [4] Nicolas Saenz and Chris P.Pantelides, M.ASCE " Shear friction capacity of concrete with external corban FRP strips" Journal of structural engineering ASCE/DECEMBER 2015.
- [5] Bryan Barragan, RavindraGettu, Luis Agullo and Raul Zerbino "Shear failure of steel fibre reinforced concrete based on push-off tests" ACI material journal/july-August 2006.
- [6] Constantinescu horia, magureanu cornelia (2011). "Study of shear behaviour of high performance concrete using push-off tests".
- [7] Dr. Maha M.S. Ridha, Nagham T. Hamad and Dr. Kaiss F. Sarsam (2012). "Predicting the Strength of Fiber Reinforced High Performance Concrete Based on Push-Off Tests", Eng and Tech Journal.
- [8] BensaidBoulekbatche, MostefaHamrat, Mohamed Chemrouk, SofianeAmziane "Influence of yield stress and compressive strength on direct shear behavior of steel fibre-reinforced concrete" journal of ELSEVIER September 2011.
- [9] Nadar nissar shaikh et al "inplane shear strength of Normal, High strength and self compacting concrete using Push-off specimen" International conference on Architecture and civil Engineering 2012.
- [10] Oh Byung Hwon, Kim Kwang Soo, Lee Jong Hoon, Han Seung Hwan " Shear transfer in Normal and High strength concrete". 2001
- [11] K.N. Rahal and A.L. Al-Khaleefi. "Behaviour of Shear Friction Push-off Specimens Made Using Normal and Recycled Aggregates" 6<sup>th</sup> International symposium on advances in science and technology, malaysia (2012).
- [12] K.N. Rahal and A.L. Al-Khaleefi "push-off shear tests of self consolidating concrete". 2013 taylor and Francis group, London.
- [13] Harish Kumar, Snehal K and Dr Prabhakara R "investigation of In-plane shear strength on Aggregate Size Variation using Push-off Specimen" journal of Civil Engineering Technology and Research Vol-2, November 1 (2014) pp.215-224.
- [14] Rahele Naserian et al " Assessment of shear transfer capacity of non-cracked concrete strengthened with external GFRP strips" journal of ELSEVIER 2013.
- [15] Benny Joseph, George Mathew "Interface Shear Strength Of Fly Ash Based Geopolymer Concrete" Annals of the Faculty of Engineering Hunedoara - International J;2013, Vol. 11 Issue 3, p105.
- [16] Estefania Cuenca et al "Shear Behavior of Self-Compacting Concrete and Fiber-Reinforced Concrete Push-Off Specimens" Design and Placement of Self-Consolidating Concrete RILEM Bookseries Volume 1, 2010, pp 429-438.
- [17] Indian Standard, "PLAIN AND REINFOCED CONCRETE CODE OF PRACTICE (fourth revision)", IS 456:2000.
- [18] Indian standard, "CONCRETE MIX PROPORTIONING (First Revision)", IS 10262: 2009