

# DESIGN OF PLEATED BAG FILTER SYSTEM FOR PARTICULATE EMISSION CONTROL IN CEMENT INDUSTRY

Abhishek P S<sup>1</sup>, Dr. P N Ramachandran<sup>2</sup>,

<sup>1</sup> M.Tech student, Energy System, Nehru College of Engineering and Research Centre, Kerala, India

<sup>2</sup> Director (Research & Development) & HOD at Nehru College of Engineering and Research Centre, Kerala, India

\*\*\*

**Abstract:** The cement industry handles billion tonnes of dust each year and does a good job in keeping dust out of the atmosphere. Over the years, the allowable dust emissions from cement plants have become lower and lower. Particulate Matter (PM) has impacts on climate and it also adversely affects the human health. Currently using process emission control device in cement plant include Electro Static Precipitator (ESP) and various types of baghouses. But this can limit the PM pollution only to 50-150mg/Nm<sup>3</sup>. According to Central Pollution Control Board (CPCB), process emission need to limit fewer than 50mg/Nm<sup>3</sup> in 2015 and it need to limit fewer than 30mg/Nm<sup>3</sup> in 2016. Replacing ESP with pleated bag house can limit the process emission to 30mg/Nm<sup>3</sup>. My paper involves designing of pulse jet pleated bag house system.

**Key Words:** Particulate Matter, Pulse Jet Baghouse, Pleated Bag

## 1. INTRODUCTION

Cement manufacturing industries are one of the important sectors of the Indian economy. The sector has experienced phenomenal growth especially after the control regime from 1999 and due to greater thrust by Government on infrastructure development and spurt in housing construction sector, which has led to increased demand for cement. The cement sector has been rapidly growing at a rate over 8% and it is expected to grow further. In view of the growth rate it is expected that more & more cement plants would come up and the existing plants may expand their capacities through upgradation or modernization. Usage of more fly ash, slag is also increasing to create additional production capacity. In order to meet the increasing demand, most cement plants are making efforts to achieve higher production levels, at times by stretching the existing production facilities and by adding additional capacities. On the other hand, the environmental concerns in terms of emissions to atmosphere are also growing. Most cement plants have made considerable efforts in controlling the stack emissions using most efficient control systems like bag

filter and ESP, and these plants generally meet the environmental regulations for stack emissions. However, fugitive emissions from various sources in cement plants still remain an area of concern. There have been environmental regulations/guidelines in terms of preventing/controlling fugitive emissions. Many cement plants though have taken initiatives in controlling fugitive emissions with varying degree of effectiveness. However in general more efforts are required in this area to satisfactorily control the fugitive emissions on sustainable basis.

### 1.1 Particulate Pollution and its Consequences

Atmospheric particulate matter also known as particulate matter (PM) or particulates is microscopic solid or liquid matter suspended in the Earth's atmosphere. The term aerosol commonly refers to the particulate/air mixture, as opposed to the particulate matter alone. Sources of particulate matter can be man-made or natural. They have impacts on climate and precipitation that adversely affect human health. Subtypes of atmospheric particle matter include suspended particulate matter (SPM), irrespirable suspended particle, respirable suspended particle (RSP) that is particles with diameter of 10 micrometres or less), fine particles (diameter of 2.5 micrometres or less), ultrafine particles, and soot. Common chemical constituents of PM include sulphates, nitrates, ammonium, other inorganic ions such as ions of sodium, potassium, calcium, magnesium and chloride, organic and elemental carbon, crustal material, particle-bound water, metals (including cadmium, copper, nickel, vanadium and zinc) and polycyclic aromatic hydrocarbons (PAH). In addition, biological components such as allergens and microbial compounds are found in PM.

The size of the particle is a main determinant of where in the respiratory tract the particle will come to rest when inhaled. Larger particles are generally filtered in the nose and throat via cilia and mucus, but particulate matter smaller than about 10 micrometers, referred to as PM<sub>10</sub>, can settle in the bronchi and lungs and cause health problems. Because of their small size, particles on the order of ~10 micrometers or less (PM<sub>10</sub>) can penetrate the deepest part of the lungs such as the bronchioles or alveoli. Similarly, so called fine PM, particles smaller than

2.5 micrometers,  $PM_{2.5}$ , tend to penetrate into the gas exchange regions of the lung (alveolus). Penetration of particles is not wholly dependent on their size; shape and chemical composition also play a major role in penetration of particulate matter. The major health effects caused by the particulate matters are lung cancer, cardiovascular disease, respiratory diseases, premature delivery, birth defects, and premature death. It has been suggested that particulate matter can cause similar brain damage as that found in Alzheimer patients. The particulate matter emission also results in reduced visibility. Particulate matter can clog on stomatal openings of plants and interfere with photosynthesis functions. Particulate matter can also cause severe climatic changes.

### 1.2 Motivation

Gas cleaning in the cement industry is an enormous task. The modern process of cement production involves crushing and grinding of carbonaceous and clayey raw materials under dry conditions, thermal processing of finely ground raw meal, i.e. preheating, precalcining and sintering in rotary kiln, cooling of the clinker (sintered material) on a reciprocating grate cooler and further grinding and packaging of the product cement. Besides this, a great amount of mechanical conveying is also involved. All these operations generate a huge quantity of gas and particulates of varying characteristics such as temperature, moisture content, particle size distribution, chemical composition, abrasiveness etc. The selection of gas cleaning equipment depends upon these characteristics. The commonly used equipment are settling chambers, conventional and high efficiency cyclones/multi-cyclones, fabric filters (FF) and electrostatic precipitators (ESP). According to the Central Pollution Control Board, the dust emission need to be limited to  $50mg/Nm^3$  in 2014 and it should be limited to  $30mg/Nm^3$  in 2016. Existing technologies such as cyclones/multi-cyclones and electrostatic precipitators (ESP) can't limit the emission levels in proposed values. Currently ESP and fabric filters are most widely used and it can only limit the emission values under  $150 mg/Nm^3$ . This two method can't limit the dust emission to  $50mg/Nm^3$ . Pleated bag filters can provide almost twice as much filtration area in existing equipment such as fabric filters, due to the increased media in the pleat pack design. Increasing filter area causes the air to cloth ratio to decrease when the airflow stays the same. The pressure drop also decreases. Advanced media is more efficient in capturing submicron dust particles. With the help of pleated bags emission can brought down to  $30mg/Nm^3$

### 2. BAGHOUSE

Baghouse use filtration to separate dust particulates from dusty gases. They are one of the most efficient and cost effective types of dust collectors available and can achieve a collection efficiency of more than 99% for very fine

particulates. Dust-laden gases enter the baghouse and pass through fabric bags that act as filters. The bags can be of woven or felted cotton, synthetic, or glass fiber material in either a tube or envelope shape. To ensure the filter bags have a long usage life they are commonly coated with a filter enhancer, that is pre-coat. The use of Polytetrafluoroethylene is most common as it maximizes efficiency of dust collection (including fly ash) via formation of what is called a dust cake or coating on the surface of the filter media. This not only traps fine particulates but also provides protection for the bag itself from moisture, and oily or sticky particulates which can bind the filter media. Without a pre-coat the filter bag allows fine particulates to bleed through the bag filter system, especially during start-up, as the bag can only do part of the filtration leaving the finer parts to the filter enhancer dustcake.

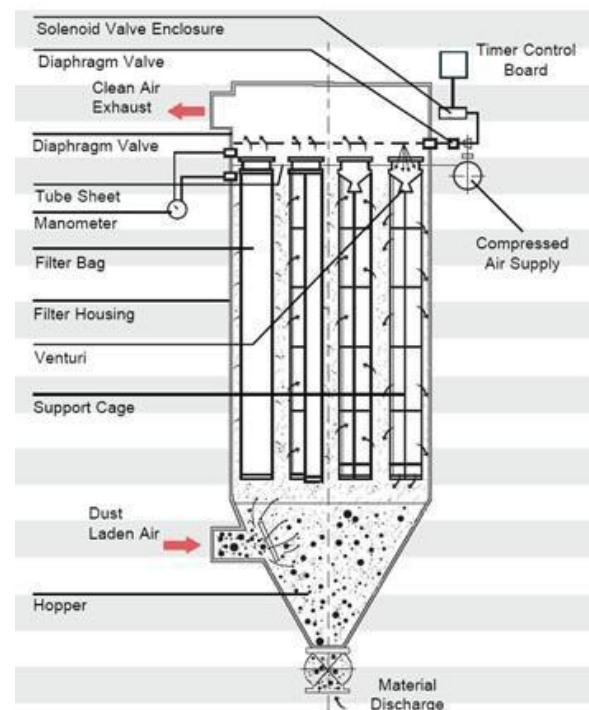

Fig-1: Pulse Jet Baghouse

#### 2.1 Working of Pulse Jet Baghouse

This type of baghouse cleaning (also known as pressure-jet cleaning) is the most common. A high pressure blast of air is used to remove dust from the bag. The blast enters the top of the bag tube, temporarily ceasing the flow of dirty air. The shock of air causes a wave of expansion to travel down the fabric. The flexing of the bag shatters and discharges the dust cake. The air burst is about 0.1 second and it takes about 0.5 seconds for the shock wave to travel down the length of the bag. Due to its rapid release, the blast of air does not interfere with contaminated gas flow. Therefore, pulse-jet baghouses can operate continuously and are not usually compartmentalized. The blast of compressed air must be powerful enough to ensure that

the shock wave will travel the entire length of the bag and fracture the dust cake.

## 2.2 Design of Pulse Jet Baghouse

### 2.2.1 Air to Cloth Ratio (G/C)

The air to cloth ratio (gas to cloth ratio) is equal to total actual volumetric flow rate in cubic feet per minute divided by the net cloth area in square feet. This ratio affects pressure drop and bag life. The net cloth area is determined by dividing the gas flow rate in actual cubic feet per minute (acfm) entering into the baghouse by the design gas-to-cloth ratio. Typical gas to cloth ratio for pulse jet fabric is 8ft/min. Also we can find the air to cloth ratio by manufacturers method [3], i.e.

$$G/C = \frac{\text{volume of air inlet (m}^3/\text{s)}}{\text{Total area of cloth required (m}^2\text{)}}$$

$$G/C = 2.878 \times A \times B \times T^{-0.2335} \times L^{0.06021} (0.7471 + 0.0853 \times \ln D)$$

A=Material factor; for cement A=10

B=Application factor Shown in table 2) [3]

C=temperature in Fahrenheit

L=Dust loading factor in g/ft<sup>3</sup>

D=mass mean diameter of particle in μm

Cement Industry Process	Application Factor
Nuisance Venting, Relief of transfer points, conveyors, packing stations, etc.	1
Product Collection ,Air conveying-venting, mills, flash driers, classifiers, etc.	0.9
Process Gas Filtration ,Spray driers, kilns, reactors, etc.	0.8

**Table-2:** Application factor

Total cloth area can be found by dividing volumetric air inlet divided by gas to cloth ratio.

### 2.2.2 Finding number of bags

Number of bags required=total cloth area/area of single bag

Area of single pleated bag= 2nhd [1]; where

h= Bag height

n= Number of pleat

d= Depth of pleat



**Fig-2;** Pleated bag

### 2.2.3 Pleated bag

The filter media is usually a felted material composed of cellulose, polypropylene, or other flex-resistant material. The unique feature of a pleated filter is the design of the filter element. Essentially all pleated filters are shorter than pulse jet bags. Some pleated filters have simple cylindrical designs. Others can have a large number of pleats in order to increase the filtering surface area. Due to the shortness of the pleated filter elements, they are usually less vulnerable to abrasion caused by the inlet gas stream. The shorter length also facilitates cleaning by a conventional compressed air pulsing system identical to those used on pulse jet collectors. Pleated filter elements are used in a wide variety of industrial applications. Due to their inherently compact design, they can be used in small collectors located close to the point of particulate matter generation. There are pleated bags of variable size and materials are available in market.

### 2.2.4 Mirror plate

The mirror plate should hold the all pleated bags. The material should be mild steel. The area of mirror plate should include space in which it will hold all the filter bags. Also equal space between the filter bags is preferred. Usually preferred thickness is 2".

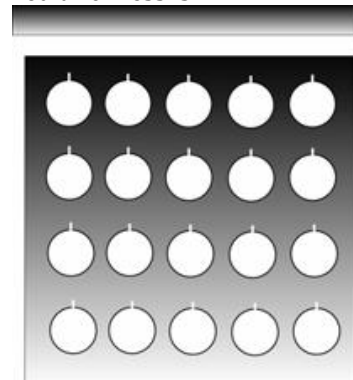

**Fig-3;** Mirror Plate

### 2.2.5 Venturi

venturis in pulse-jet units claim that the venturis can help increase in cleaning pressure, and thereby improve bag cleaning. It optimizes energy use resulting in more efficient cleaning. Venturi's sealed at the top of each bag or just inside the top of each bag is used to create a large enough pulse to travel down and up the bag. Preferred length of venture is 3" and inner diameter is 3"-1" -2". But venturis of various types are available in market.

### 2.2.6 Compressor System

The compressed air system needs to be operated with an effective pressure ranging from 90psi to 110psi (normally 100). Attach the compressed air reservoir and connect the valves and the blowing tubes as shown in the Figure (4 and 5). The performance of the blowing tubes needs to be rigorously aligned with the holes in the mirror. This is required to ensure that all types of leakage are removed from the connections. It is preferred to clean the bag alternatively than consequently. Utilization of cleaning and

collection of dust particle in hopper is high in this type of methods [9]. Blow pipe of 2" diameter is usually preferred.

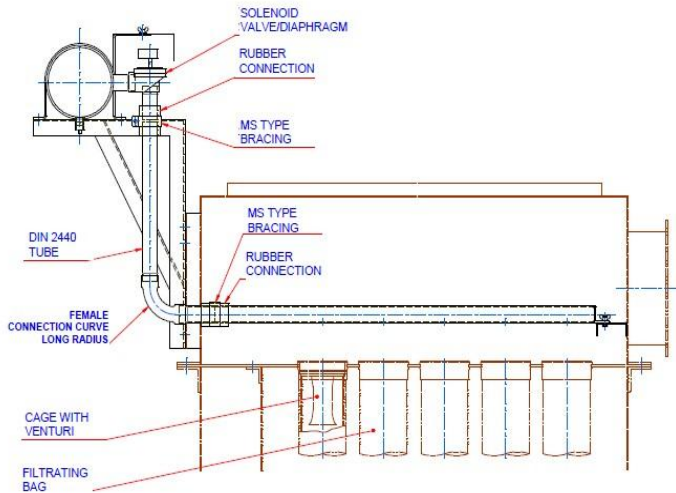

Fig-4: Compressor System Assembly (side view)

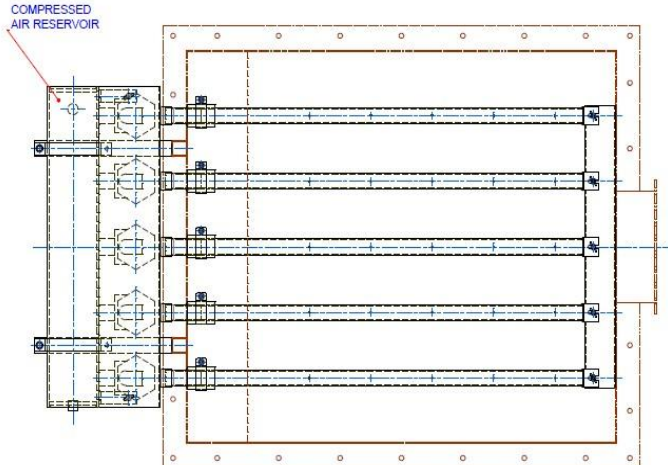

Fig-5: Compressor System Assembly (Top view)

### 2.2.7 Electronic Sequential Programmer

Electronic sequential timer will give electric pulses to the solenoid valve which initialize the opening of diaphragm valve hence the passage of the compressed air to the bag filter. Pulse time is 100 millisecond. Pulse duration time is of 1 minute for each row of filters.

### 2.2.8 Solenoid and 2.2.8 Diaphragm valve

With the help of pneumatic pulses from the electronic sequential meter solenoid initializes the opening of diaphragm valve. There are so many types of solenoids and diaphragms valves are available in market. Preferred material for pulse jet baghouse is stainless steel. Valve description for diaphragm valve is 2/2

### 2.2.9 Area of Inlet Plenum

It can be found by the equation

$$Q = A \times V$$

Q = Volume of air inlet

A = Area of plenum  
V = Velocity of air inlet  
**2.2.10 ID fan design**

Backward curved centrifugal fan is preferred because of its high efficiency. Fans having 75% is available in market. Direct driven fan is preferred. Power input to the fan shaft =  $\frac{\text{volume in } \frac{\text{m}^3}{\text{s}} \times \text{total pressure in mmwg}}{102 \times \text{static efficiency of fan}}$

With the required volumetric inlet flow, power and size; rpm can be found.

### 2.2.11 Hopper Design

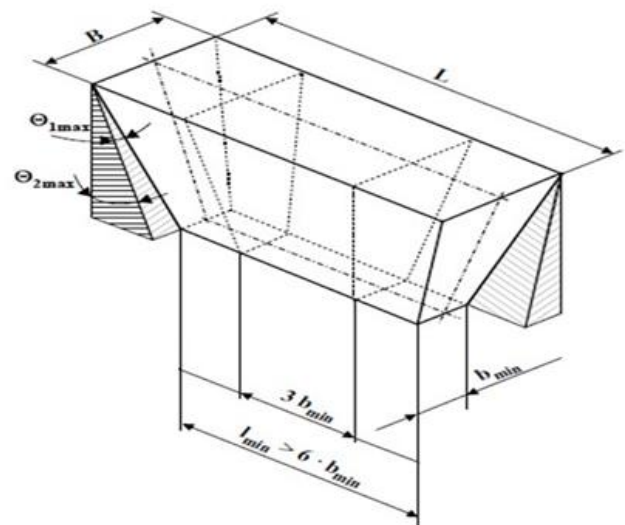

Fig-5: Hopper

Since cement particles are free flowing; inclination angle for side equal and greater than 30° greater can be used. The length and breadth can be designed according to the size of mirror plate. Breadth of bottom part of hopper can be designed according to space left for the screw conveyer and from all these values height can be found. [18]

### 2.2.12 Baghouse Body

Baghouse is usually made of mild steel with 2" thickness and 10mm insulation of glass fibre and aluminium coating around glass fibre. Also height of baghouse body can be designed according to height of pleated bag and space left for passage of air in bottom and top of pleated filter.

### 2.2.13 Baffle Plate

It helps the heavy dust particles to fall directly to hopper. 2" thickness of mild steel is preferred for the baffle plate. Length of the baffle plate will be equal to breadth of baghouse. Height of the baffle plate will be sum of height of pleated bag filter and sometimes the space left above the pleated bag. This will vary according to various types of design.

### 2.2.14 Screw Conveyor

A screw conveyor or auger conveyor is a mechanism that uses a rotating helical screw blade, called a "flighting", usually within a tube, to move liquid or granular materials.

Since port land cement is very fine, free flowing and moderately abrasive 30% loading can be made [12]. After that loading at one rpm in ft<sup>3</sup>/hr for required diameter and coupling size can be found from table 3.

Diameter	Ribbon width in inches	Cubic feet per hour at one RPM
4	1	.44
6	1.5	1.50
9	1.5	5.40
	2	
10	1.5	7.60
	2	
12	2	13
	2.0625	
	3	
14	2.0625	21
	3	
16	3	31.4
18	3	45.5
20	3	62
	3.0625	
24	3.0625	108

**Table-3** Capacity chart for 30% loading

For standard full pitch screw conveyer, diameter of screw conveyer is equal to length between the ribbons. Required capacity to be swept by screw conveyer can be found from multiplying dust loading and inlet volume. [12]

Required capacity to be swept by screw conveyer (ft<sup>3</sup>/hr) = Dust loading x volume of inlet in hour

Next is to find the design capacity

Design capacity = required capacity x capacity factor

Capacity factor for 30% loading is given in table 4.

Next is to find the speed of screw conveyer.

Speed of screw conveyer, N (rpm) = Design Capacity

(ft<sup>3</sup>/hr) ÷ Capacity swept at one revolution (ft<sup>3</sup>/hr) [12]

Screw conveyer H.P can be found by equation

Conveyer H.P= L (DS+QF)/1000000 [12]

Where L= Length of conveyer in feet; D=Friction factor; for cement hard iron is used given in table 5, S=Speed of revolution, Q=Quantity of material conveyed in lbs/hr, F=Horse power factor, for hard iron it is 1.4

Diameter	Ribbon width inches	Capacity factor for 30% loading
6	1	1.52
9	1.5	1.54
10	1.5	1.67
12	2	1.52
	2.5	
14	2.5	1.45
16	2.5	1.69
18	3	1.53
20	3	1.75
24	3	2.14

**Table-4** Capacity factor for 30% loading

Screw Diameter inches	Friction factor
4	50
6	80
9	130

10	160
12	250
14	350
16	480
18	600
20	700
24	950

**Table-5** Friction factor for hard iron

### 2.2.15 Rotary Airlock Valve

Rotary feeders are primarily used for discharge of bulk solid material from hoppers/bins, receivers, and cyclones into a pressure or vacuum-driven pneumatic conveying system. Rotors have large vanes cast or welded on and are typically driven by electric motors. The basic use of the rotary airlock feeder is as an airlock transition point, sealing pressurized systems against loss of air or gas while maintaining a flow of material between components with different pressure and suitable for air lock applications ranging from gravity discharge of filters, rotary valves, cyclone dust collectors, and rotary airlock storage devices to precision feeders for dilute phase and continuous dense phase pneumatic convey systems. Valves are sized on volumes. Throughput is usually expressed in lbs or tons / hour, but for valves selection it must be converted into cubic feet / hour.

To calculate valve throughput/hr(ft<sup>3</sup>/hr)=inlet material quantity(lbs/hr)/Bulk density(lbs/ft<sup>3</sup>)

To select valve size and speed refer figure 6 [14]

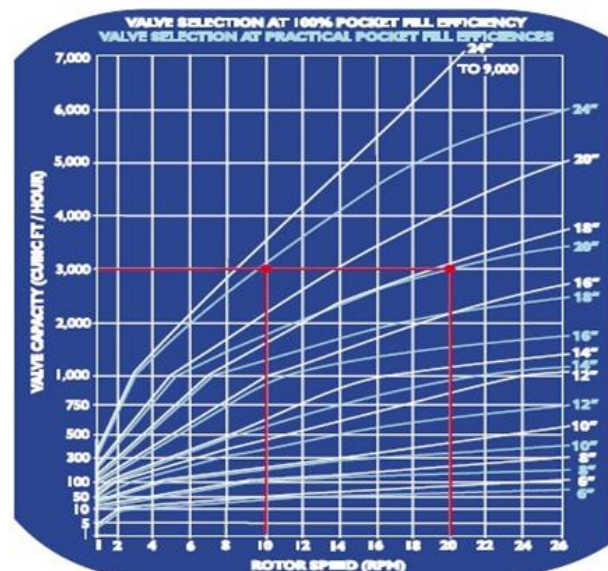

**Fig-6** valve size, speed and valve capacity chart

### 3. CONCLUSION

Pleated bag filters offer up to 2-3 times the filter life over conventional polyester felt bags. Particulate matter emission will reduce to 30mg/Nm<sup>3</sup>. Also size of the baghouse will be reduced compared to conventional baghouse (woven or felt) system. This pleated bag is more

efficient in capturing submicron dust particles .Longer filter life and better pulse cleaning due to surface loading technology is offered. This has lower energy consumption with better pulse cleaning and lowers operating pressure drop. Cleaner air, longer filters life, and greater cost savings.

## REFERENCE

- [1] John R. Richards, "Control of Particulate Matter Emissions", Air Pollution Training Institute and United States Environmental Protection Environmental Research Centre Agency Research Triangle Park, January 2000
- [2] Santosh Kumar Prajapati, "Ecological effect of airborne particulate matter on plants", Environmental Skeptics and Critics, 10 March 2012
- [3] James H. Turner, "Particulate Matter Controls", December 1998
- [4] Christopher J.Polizzi et.al"Optimizing Kiln Operations by Improving Baghouse Performance", W. L. Gore & Associates, Inc., 2001
- [5] D.Zimwara et.al, "Air Pollution Control Techniques for the Cement Manufacturing Industry: A Case Study for Zimbabwe", CIE42 Proceedings 16-18 July 2012, Cape Town, South Africa
- [6] Syed Sana Mehraj "Cement Factories, Air Pollution And Consequences", 2012
- [7] Michael Porter "Profiting From Better Air Flow in Baghouses", Cement Industry Technical Conference, 2010 IEEE-IAS/PCA 52nd, March 28 2010-April 1, 2010
- [8] C. Thorn Martin, "Fine Filtration Fabric Options Designed for Better Dust Control and to meet PM2.5 Standards", Cement Industry Technical Conference, 1999. Conference Record. 1999 IEEE-IAS/PCA, 1999
- [9] Technical Manual for Installation, Operation and Maintenance Bag Filter Ventec Ambiental, 28-11-2008
- [10] "Particulate Matter Expertise", GE energy, 2011
- [11] Backward Curved Centrifugal Fans, HARTZEL Fan, Inc. Piqua, Ohio may 2009
- [12] Screw Conveyor Catalogue and Engineering Manual, Continental Conveyer, Thetford Mines, Quebec, Canada, 1986
- [13] "Rotary Airlocks the Power in Powders", Carolina Conveying, Beaverdam Industrial Park, Great Oak Drive, Canton
- [14] "Screw Conveyors Engineering Guide & Parts Catalogue", WAM Inc., Texas, 2006
- [15] "Assessment of Fugitive Emissions & Development of Environmental Guidelines for Control of Fugitive Emissions in Cement Manufacturing Industries", Central Pollution Control Board, Parivesh Bhawan, East Arjun Nagar, Delhi, July 2007
- [16] Charles E .Billings et.al, "Handbook of Fabric Filter Technology, Volume 1, GCA Corporation, Massachusetts, December 1970
- [17] Pulse Jet Filter Operation and Maintenance Manual, South highway, Falls City, February 2009
- [18] MSA Bradley et.al, "Methods for Design of Hoppers. Silos, Bins and Bunkers for Reliable Gravity Flow, for Pharmaceutical, Food, Mineral and Other Applications", Chatham, UK
- [19] Lawrence K. Wang et.al,"Fabric Filtration", Springer Air pollution Control Engineering, 2004
- [20] A. Buekens, "Control of Particulate Matter in Gaseous Emissions", Pollution Control Technologies volume 1, vrije University Brussel, Belgium

## BIOGRAPHIES



ABHISHEK P S  
M.TECH, ENERGY SYSTEM  
NEHRU COLLEGE OF  
ENGINEERING & RESEARCH  
CENTRE PAMPADY, KERALA ,  
INDIA



DR. P N RAMACHANDRAN  
DIRECTOR (RESEARCH &  
DEVELOPMENT) AND HEAD OF  
ELECTRICAL AND ELECTRONICS  
DEPARTMENT AT NEHRU  
COLLEGE OF ENGINEERING AND  
RESEARCH CENTRE, PAMPADY,  
KERALA, INDIA