

# Soil Structure Interaction of Framed Structure Supported on Different Types of Foundation

Bhojegowda V T<sup>1</sup>, Mr. K GSubramanya<sup>2</sup>

<sup>1</sup>Post graduate student, Civil Engineering Department, GOVT. S.K.S.J.T.I, k.r circle, bengaluru, Karnataka, India

<sup>2</sup>Assistant Professor, Civil Engineering Department, GOVT. S.K.S.J.T.I, k.r circle, bengaluru, Karnataka, India

\*\*\*

**Abstract-** *In the analysis of framed structure the base is considered to be fixed neglecting the effect of soil and foundation flexibility. Flexibility of the soil causes the decrease in stiffness resulting increase in the natural period of the structure. Such increase in the natural periods, changes the seismic response of structure hence it may be an important issue for design considerations. The present study provides systematic guidelines for determining the natural periods of frame buildings due to the effect of soil-flexibility and identification of spring stiffness for different regular and irregular story buildings and various influential parameters have identified and the effect of the same on change in natural periods has to be studied. The study has carried out for building with Isolated, mat and pile foundations for different soil conditions like soft, medium and hard strata, and a comparison between the regular and irregular buildings and natures of change in the natural periods has to be present. And response spectrum analysis this study may useful for seismic design.*

**Key Words:** Soil Structure Interaction, Spring Stiffness, Soil Flexibility, Base Shear, Displacement, Period.

## 1. INTRODUCTION

The rapid development of urban population and the pressure on limited space significantly influence the residential development of the city. The price of the land is high, the desire to avoid uneven and uncontrolled developing of urban area and bear on the land for needs of important agricultural production activity have all led to route residential building upwards. The local topographical restrictions in the urban area only possible solutions for construction of multi-storey buildings to full fill the residential needs. The multi-storey buildings all initially a reaction to the demand by activity of business close to each other and in city center, the less availability of land in the area. The multi-storey buildings are frequently developed in the centre of the city is prestige symbols for commercial organizations. Further, the tourist and business community.

The soil structure interaction is a special field of analysis in earthquake engineering, this soil structure interaction is defined as "The dynamic interrelationship

between the response of the structure is influenced by the motion of the soil and the soil response is influenced by the motion of structure is called a soil structure interaction." However engineering community discussed about SSI only when the basement motion by interaction force as compared to the ground motion of free field. The stress and deformation in the supporting soil cause vibration of structure generates base shear, moment, displacement and alter the natural period, since in reality it is not fixed base structure, the deformation of soil further modify the response of the structure.

The structure with irregularity have to be designed at most care by understanding determinantal effects of irregularities to full fill the requirements. The research finding the effect of irregularities have discussed mainly on plan irregularities because of its mass distribution, non-uniform stiffness and strength in the horizontal direction. Even though the structures are of the same region, same configuration and same earthquake magnitude, but the damages that occur during the earthquake are not of the same pattern. This means that there are some factors that affects the damage pattern like earthquake characteristics, structural system of plan, mass, stiffness, and vertical irregularities

## 2. LITERATURE REVIEW

**Koushik Bhattacharya et.al (2006)**, Studied the effect of soil structure interaction which was ignored in the design of a low rise building resting on shallow foundation, ignoring such effects it may create an unsafe seismic design. Later the effect of soil structure interaction is considered for low rise building to conducted the investigation for formulating direct design guidelines, calculated the design spectrum based on code specified for the elastic domain. Dynamic characteristic of the building with various numbers of storeys, bays, etc..are computed to seismic vulnerability of low rise building with isolated footing and Mat foundation. The study attempts to identify the influence of various parameter effects to regulating the SSI of base shear and torsional to lateral period ratio for low rise building. A number of curves forming a variation of these two parameters, these curves help with evaluation of the effect of SSI and important to dynamic characteristic parameters for designers, at least

preliminary seismic design identify the expected vulnerability by ignoring the influenced SSI in the process of design.

**Ravikumar C M et.al (2012)**, Addressed many buildings have irregular configurations in both plan and elevation. This in a future earthquake subjected to devastating such type of buildings. In case, it identifies the necessary performance of the new and existing structure to withstand against disaster. This paper studied the two kinds of irregularities in the structure, namely plan irregularity with diaphragm and geometric discontinuity and vertical irregularity with sloping ground and setback. This irregularity is framed as per IS 1893 (part 1), class 7.1 code. The considered in identifying the most vulnerable buildings, in both linear and nonlinear seismic demands to identify the performed various analytical approaches. It is also tested by different lateral loads for various irregular buildings with the performance of pushover analysis. Finally, the result shows that the building capacity may be significant, but the seismic demand differs with respect to the configuration. The eccentricity between centre of rigidity and centre of mass is differ in the absence of dual system. This study generates the awareness of seismic vulnerability in practicing engineering.

**Dutta S C et.al (2010)**, Proposed study is considering SSI in soil pile structure system for investigating the seismic response. In general, Pile foundation and structure under seismic loads of base shear is designed and estimating for the fixed base condition. However, soil flexibility in the base of the structure changes the soil pile foundation structure response system. This system is considered an idealized one story system consisting of a mass in rigid deck supported by four columns and rests on raft foundation with pile. This type of pile is modelled by column, beam element and springs are distributed laterally by supporting pile. The flexibility variations are considered to the response is consistent for ground motion. A changes in the shear force transmitted columns of soil is observed as compared to the results in SSI effect to fixed base condition. Summarily the study indicated the total shear carrying capacity is underestimated for soil and the column is over estimated for shear for considered in fixed condition. The design shear force of a pile is closely transmitted for total shear. Hence, the fixed base assumption condition design of column over safe and design of pile unsafe. Finally, this study indicated the considering SSI in design.

### 3. MODLING AND ANALYSIS

#### 3.1 Details of Soil Parameters Considered

The soil-flexibility effects on frame building resting on different types of soils, viz, hard, medium, soft is also trying to be studied in the present work.

The value of the spring's stiffness of the varieties of soil, the shear modulus (G) is estimated to use the following expression.

$$G = Vs^2 \rho$$

The shear wave velocity is estimated to use the following expression.

$$Vs = \sqrt{E / (2\rho(1 + \nu))}$$

$\rho$  = mass density of soil in kN/m<sup>3</sup>

**Table 5.1 Details of soil parameters considered**

Type of Soil	N value Considered	Mass density ( $\rho$ ) kN/m <sup>3</sup>	Shear wave velocity (m/sec)	Poisson ratio ( $\nu$ )
Hard	40	21	111.2697	0.25
Medium	20	18.5	84.3349	0.33
Soft	9	17	54.5978	0.48

Where,

N = applied for Number of in Standard penetration test (SPT) on the soil.

Vs = Shear wave velocity, in m/sec.

$\rho$  = mass density of soil in kN/m<sup>3</sup>

( $\nu$ ) = Poisson ratio

Correlation between N-value,  $\phi$ , and the bearing capacity

**Table 5.2 N and  $\Phi$  value are used to get SBC and the width of footing the fig shown above**

Type of Soil	N value	Angle of internal friction $\phi$ in degree	Allowable SBC of soil kN/m <sup>2</sup>	Width of the footing m
Hard	40	38.5	500	1.5
Medium	20	33	220	2
Soft	9	29	140	2.6

**Table 5.3 Expressions for Static stiffness of equivalent soil springs along various degrees of freedom**

Degrees of freedom	Stiffness of equivalent soil spring
Horizontal (longitudinal dire) $K_{xx}$	$[2GL/(2-\nu)](2+2.50\chi^{0.85})-[0.2/(0.75-\nu)]GL[1-(B/L)]$
Vertical $K_{yy}$	$[2GL/(1-\nu)](0.73+1.54\chi^{0.75})$ with $\chi = Ab/4L^2$
Horizontal (lateral direction) $K_{zz}$	$[2GL/(2-\nu)](2+2.50\chi^{0.85})$ with $\chi = Ab/4L^2$
Rocking (about the longitudinal) $K_{rxx}$	$[G/(1-\nu)]I_x^{0.75}(L/B)^{0.25}[2.4+0.5(B/L)]$
Torsion $K_{xy}$	$3.5GI_x^{0.75}(B/L)^{0.4}(I_x/B^4)^{0.2}$
Rocking (about the lateral) $K_{rzz}$	$[3G/(1-\nu)]I_y^{0.75}(L/B)^{0.15}$

Degrees of freedom	Stiffness of foundation at surface
Translation along x-axis	$K_{xx,sur} = \{GB/(2-\nu) [3.4(L/B)^{0.65}+1.2]\}$
Translation along y-axis	$K_{yy,sur} = \{GB/(2-\nu) [3.4(L/B)^{0.65}+0.4(L/B)+0.8]\}$
Translation along z-axis	$K_{zz,sur} = \{GB/(1-\nu) [1.55(L/B)^{0.75}+0.8]\}$
Rocking about the x-axis	$K_{rx,sur} = \{GB^2/(1-\nu) [0.4(L/B)+0.1]\}$
Rocking about the y-axis	$K_{ry,sur} = \{GB^2/(1-\nu) [0.47(L/B)^{2.4}+0.034]\}$
Torsion about z-axis	$K_{rz,sur} = \{GB^3 [0.53(L/B)^{2.45}+0.51]\}$

Degrees of freedom	Correction Factor for Embedment
Translation along x-axis	$\beta_x = [1+0.21\sqrt{(D/B)}] [1+1.6(hd(B+L)/BL^2)^{0.4}]$
Translation along y-axis	$\beta_y = \beta_x$
Translation along z-axis	$\beta_z = [1+(D/21B) (2+2.6(B/L))] [1+0.32((d(B+L))/LB)^{(2.3)}]$
Rocking about the x-axis	$\beta_{rx} = [1+2.5(d/B)] [1+((2d/B)(d/D))^{-0.2}\sqrt{(B/L)}]$
Rocking about the y-axis	$\beta_{ry} = 1+1.4(d/L)^{0.6} [1.5+3.7(d/L)^{1.9}+(d/D)^{-0.6}]$
Torsion about z-axis	$\beta_{rz} = 1+2.6(1+(B/L))(d/B)^{0.9}$

Degrees of freedom	Spring stiffness of pile foundation
Translation along x-axis	$K_{xx} = ((8Gr/2-\nu) \times (1+(2d/3r)))$
Translation along y-axis	$K_{yy} = K_{xx}$
Translation along z-axis	$K_{zz} = ((4Gr/1-\nu) \times (1+0.4(d/r)))$
Rocking about the x-axis	$K_{rx} = K_{xx} (\sum_{i=1}^{np} d_{xi}^2)$
Rocking about the y-axis	$K_{ry} = K_{yy} (\sum_{i=1}^{np} d_{yi}^2)$
Torsion about z-axis	$K_{rz} = K_{zz} (\sum_{i=1}^{np} (d_{xi}^2 + d_{yi}^2))$

Note:  $d_i$  effective depth of embedment for  $i^{th}$  footing.

### 5.5 DESCRIPTION OF ANALYTICAL MODEL

Different building models are analysed in ETABS. The properties of the building configurations are considered in the present work are summarized below.

#### 5.5.1 SPECIFICATION OF THE BUILDING

Height of each floor: 3m

Plan dimension: 12x9m

Floor thickness: 0.15m

Wall thickness: 230mm

Parapet wall thickness: 230mm

Compressive strength of concrete  $f_{ck}=30$  N/mm<sup>2</sup>

The steel used Fe = 500 N/mm<sup>2</sup>

Density of concrete: 25 kN/m<sup>3</sup>

Density of concrete: 20 kN/m<sup>3</sup>

Poisson's Ratio: 0.15

Damping: 0.05

Size of column: 250mmx450mm

Size of beam: 250mmx450mm

Moderate seismic zone: (III)

Live load on top story: 2 kN/m<sup>2</sup>

Live load on remaining story: 4 kN/m<sup>2</sup>

The floor finish load is: 1.5 kN/m<sup>2</sup>

Wall load is: 11.73 kN/m<sup>2</sup>

The parapet wall load is: 6.9 kN/m<sup>2</sup>

Flexible footing details:

Depth of footing D = 1.5m

Depth to the centroid of effective side wall contact  $h = 1.25$ m (for isolated footing)

Height of effective side wall  $d = 0.5$ m (for isolated footing only)

Depth to the centroid of effective side wall contact  $h = 1.2$ m (for medium soil mat footing)

Thickness of mat slab  $d = 0.6$ m (for medium soil)

Depth to the centroid of effective side wall contact  $h = 1.175$ m (for soft soil mat footing)

Thickness of mat slab  $d = 0.65$ m (for soft soil)

Isolated footing is provided for 5 stories (hard, medium and soft soil) and 10 story hard soil

Mat foundation has provided for 10 stories (medium and soft soil) and 5 stories (hard, medium and soft soil)

Pile foundation is provided 15 stories (hard, medium and soft soil)

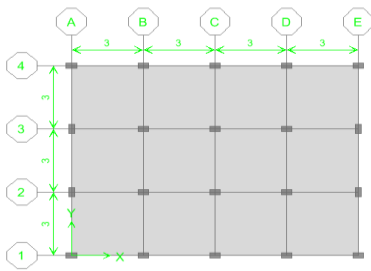

Fig.5.9 Plan of the regular building

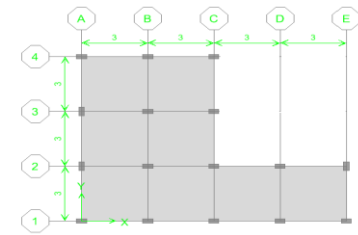
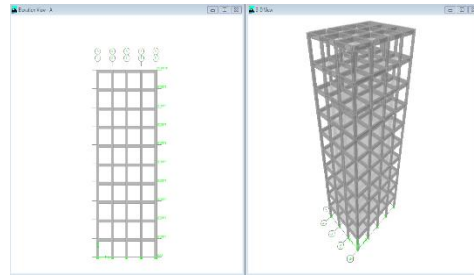
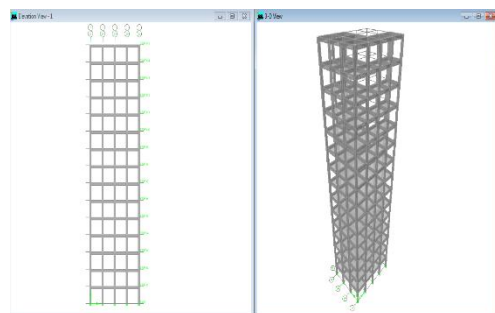
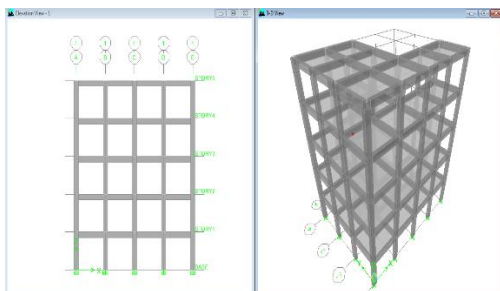
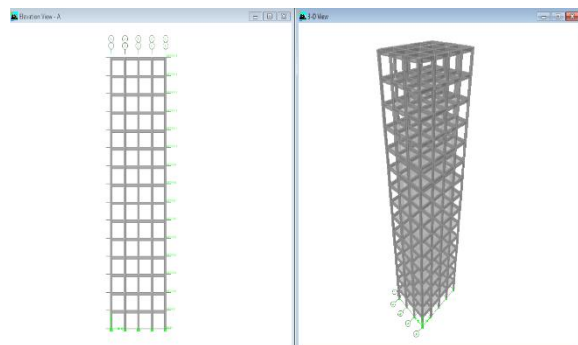
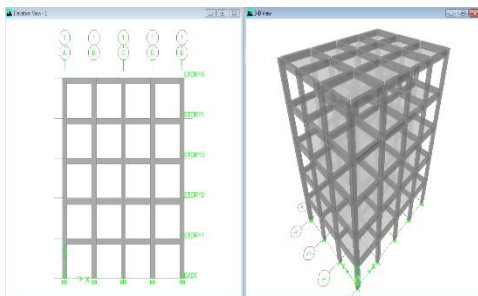
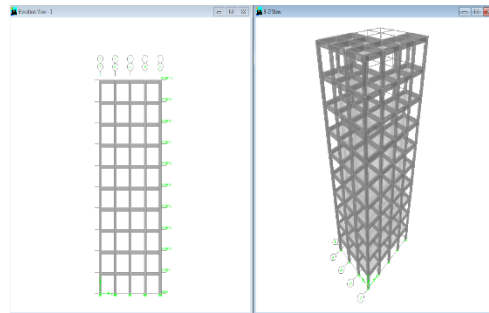

Fig.5.10 Plan of the irregular building



Soil type	L (m)	B (m)	$K_{ex}$ (kN/m)	$K_{ey}$ (kN/m)	$K_{ez}$ (kN/m)	$K_{exx}$ (kN-m/deg)	$K_{eyy}$ (kN-m/deg)	$K_{ezz}$ (kN-m/deg)
Hard	1.5	1.0	43545.98	87424.22	45009.56	11938.95	9779.03	7302.94
	1.5	1.2	46205.55	93875.66	47058.58	15931.94	15244.27	8245.576
	1.8	1.5	53670.59	110934.7	54481.7	25639.75	24845.51	11193.18
Medium	2.0	1.4	28965.48	64082.71	29881.34	14071.64	10290.82	7242.058
	2.0	1.9	32378.25	71986.53	32524.04	22558.36	21580.94	8943.39
	2.8	2.0	37872.5	83792.89	39000.6	30991.79	22210.34	19023.39
Soft	2.6	2.0	15455.81	40345.59	15885.57	14573.27	8790.86	7977.642
	2.6	2.2	16051.71	41735.67	16333.83	16901.5	11120.74	8518.2
	3.4	2.6	19156.7	48899.44	19696.77	26713.93	15444.36	17612.18

Soil Type	D (m)	d (m)	$K_{ex}$ (kN/m)	$K_{ey}$ (kN/m)	$K_{ez}$ (kN/m)	$K_{exx}$ (kN-m/deg)	$K_{eyy}$ (kN-m/deg)	$K_{ezz}$ (kN-m/deg)
Hard	0.6	8	669565.1	669565.1	485335.7	24740958.1	8454217.9	45795793.9
	0.5	8	663622.2	663622.2	478402.3	24387515.8	8333443.4	45389322.3
Medium	0.6	10	439121.7	439121.7	337784.7	17219253.2	5883980.6	30034311.3
	0.5	10	435970.2	435970.2	333857.0	5815562.3	5815562.3	29818754.0
Soft	0.6	13	239153.4	239153.4	214396.9	10929311.8	3734648.583	16357215.14
	0.6	10	185810.6	185810.6	167619.6	8544734.6	2919816.2	12708765.6

Soil type	L (m)	B (m)	$K_{ex}$ (kN/m)	$K_{ey}$ (kN/m)	$K_{ez}$ (kN/m)	$K_{exx}$ (kN-m/deg)	$K_{eyy}$ (kN-m/deg)	$K_{ezz}$ (kN-m/deg)
Hard	1.5	1.0	43545.98	87424.22	45009.56	11938.95	9779.038	7302.949
	1.5	1.2	46205.55	93875.66	47058.58	15934.94	15244.27	8245.576
	1.6	1.5	51282.65	105695.2	51555.93	23646.9	25462.27	9861.177
Medium	2	1.5	29661.33	65719.3	30416.37	15643.63	12211.13	7583.673
	2	1.9	32378.25	71986.53	32524.04	22558.36	21580.94	8943.39
	2.7	2.0	37283.96	82554.21	38273.62	30180.71	22523.89	17508.68
Soft	2.6	1.6	14231.13	37446.49	14974.83	10365.36	4966.876	6882.995
	2.6	2.3	16345.87	42418.62	16555.98	18124.2	12395.57	8788.55
	3.3	2.6	18919.3	48356.63	19392.76	26131.74	15615.25	16440.16

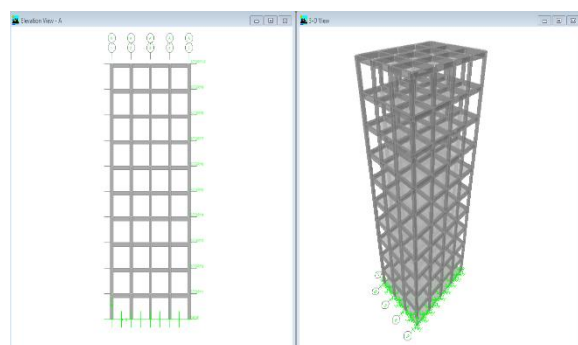
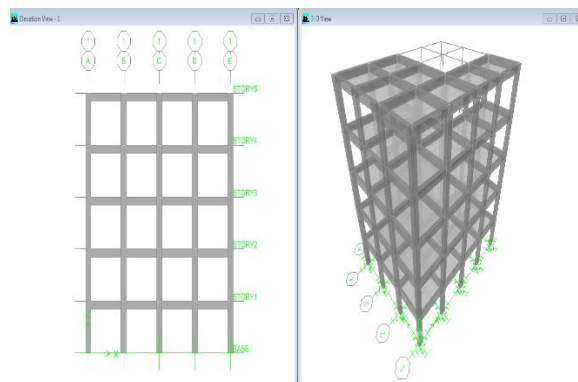
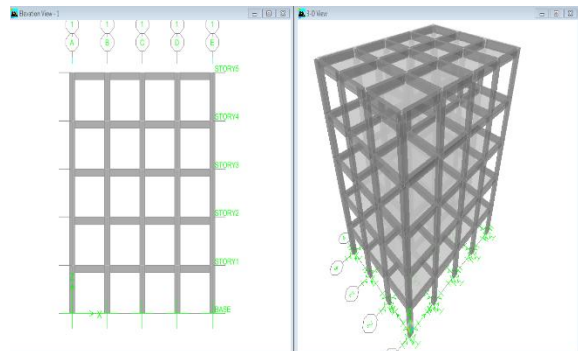

Soil type	L (m)	B (m)	$K_{ex}$ (kN/m)	$K_{ey}$ (kN/m)	$K_{ez}$ (kN/m)	$K_{exx}$ (kN-m/deg)	$K_{eyy}$ (kN-m/deg)	$K_{ezz}$ (kN-m/deg)
Hard regular stories	1.8	1.5	53670.59	110934.7	54481.7	25639.75	24845.51	11193.18
	2.4	1.5	60587.77	125781.3	62964.67	31517.45	22407.27	19602.35
	3.2	1.5	69332.21	144286.8	73733.7	39173.78	18598.19	38101.14
Hard irregular stories	1.8	1.5	53670.59	110934.7	54481.7	25639.75	24845.51	11193.18
	2.4	1.5	60587.77	125781.3	62964.67	31517.45	22407.27	19602.35
	3.0	1.5	67190.71	139761.8	71090.54	37275.72	19530.97	32736.48

Soil type	L (m)	B (m)	$K_{ex}$ (kN/m)	$K_{ey}$ (kN/m)	$K_{ez}$ (kN/m)	$K_{exx}$ (kN-m/deg)	$K_{eyy}$ (kN-m/deg)	$K_{ezz}$ (kN-m/deg)
Medium	12	9	26810.82	58735.18	26810.82	14531.36	13863.41	9097.835
Soft	12	9	11391.32	29235.56	11391.32	7601.439	5482.191	5914.376

Soil type	L (m)	B (m)	$K_{ex}$ (kN/m)	$K_{ey}$ (kN/m)	$K_{ez}$ (kN/m)	$K_{exx}$ (kN-m/deg)	$K_{eyy}$ (kN-m/deg)	$K_{ezz}$ (kN-m/deg)
Hard	12	9	48946.17	102252.2	48946.17	19352.9	23813.18	7213.643
Medium	12	9	25956.93	57925.84	25956.93	10963.41	12051.2	4086.525
Soft	12	9	10983.47	28744.65	10983.47	5440.393	4641.342	2027.864

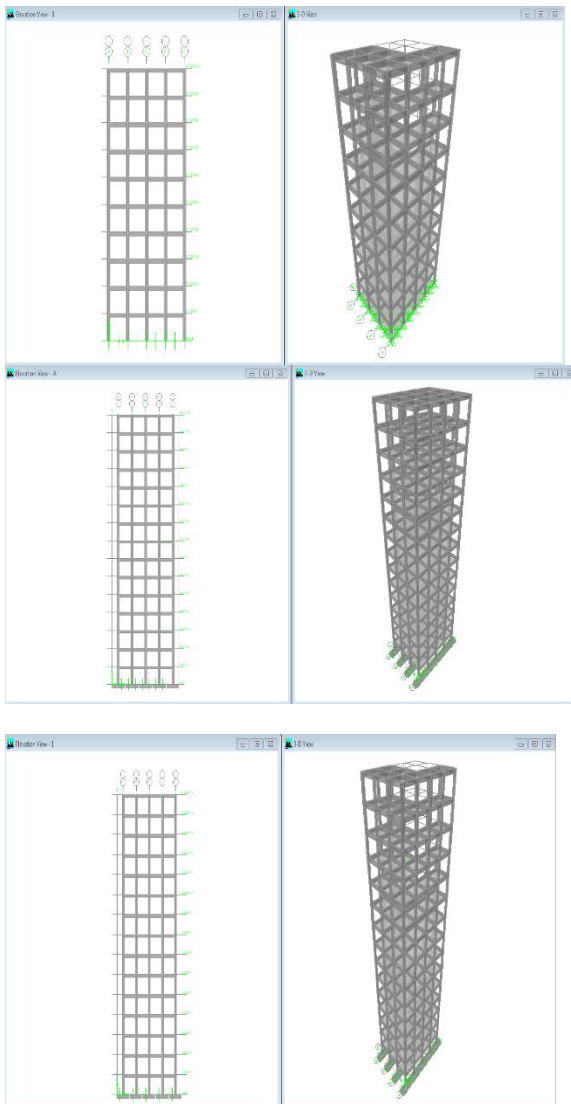

### RESULTS AND DISCUSSION

The present work attempts to study the behaviour of framed structures with rigid and flexible foundation.

Framed structure of different height with symmetrical and irregular plans have been considered with fixed and flexible foundation resting on three different types of soil and different types of foundation.

A framed structure of rectangular plan with 5, 10 and 15 storey is analysed for earthquake load consider in zone-III, importance factor of 1.5, with the different soil type like hard, medium and soft soil with fixed and flexible base condition. Response spectrum analysis is done and the parameters like time period, base shear, bending moment in column and top storey displacement are measured and are present below.

For 5 storeys framed structure the foundation are designed as isolated footing. For 10 storey framed structure the foundation for hard soil is isolated footing,

for medium and soft soil is design as mat foundation. For 15 storeys framed structure the foundation are designed as pile foundation.

5, 10 and 15 storeys frame is considered and is analysed for dead load, live load. and earthquake load with base as fixed and flexible, the response of the structure is measured with the different soil type. In the flexible base condition the soil and foundation is modelled as spring element. The stiffness of spring is calculated based on soil properties and foundation details using empirical formulae as presented in previous sections.

STOREY	REGULAR BUILDING		IRREGULAR BUILDING	
	FIXED	FLEXIBLE	FIXED	FLEXIBLE
5	356.46	273.59	261.84	190.04
10	351.78	292.54	254.18	204.25
15	337.72	329.38	240.13	232.73

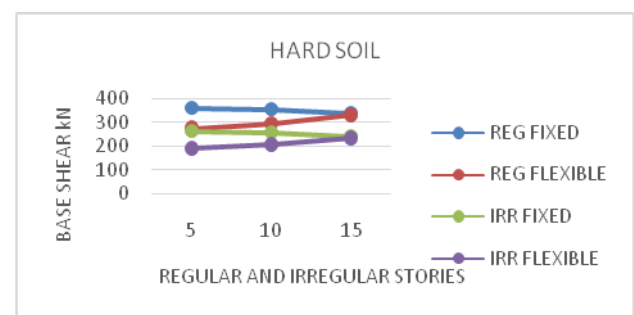

STOREY	REGULAR BUILDING		IRREGULAR BUILDING	
	FIXED	FLEXIBLE	FIXED	FIXED
5	484.78	355.04	5	484.78
10	478.78	354.22	10	478.78
15	459.3	443.3	15	459.3

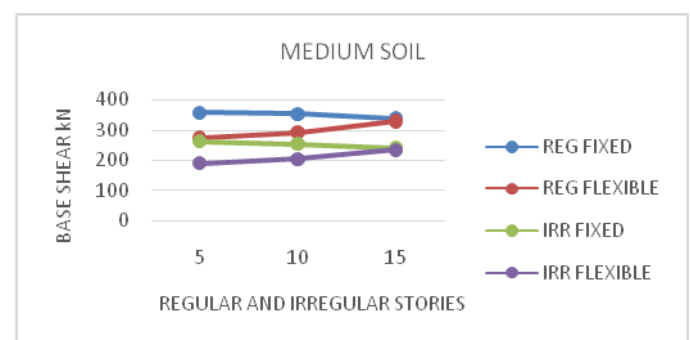

STOREY	REGULAR BUILDING		IRREGULAR BUILDING	
	FIXED	FLEXIBLE	FIXED	FIXED
5	595.28	405.48	437.27	285.72
10	587.47	474.51	424.48	326.61
15	563.71	529.08	401.02	370.92

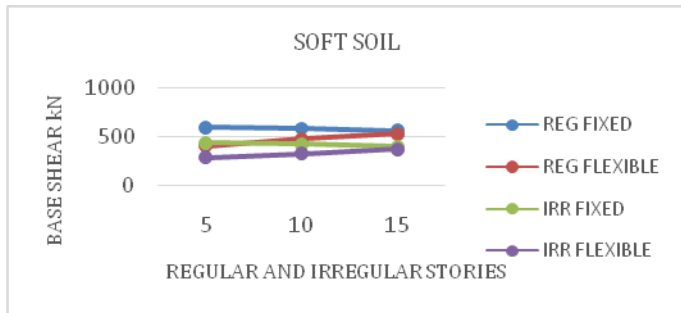
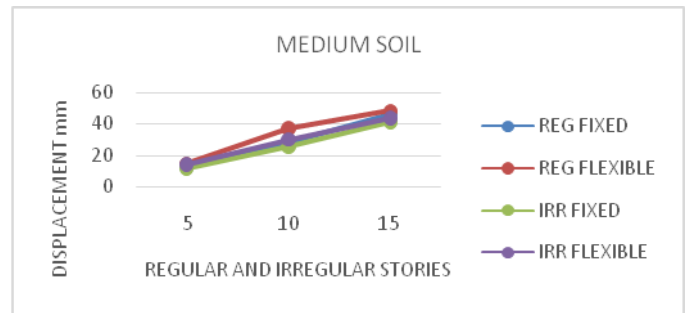

STOREY	REGULAR BUILDING		IRREGULAR BUILDING	
	FIXED	FLEXIBLE	FIXED	FIXED
5	19.9	19.9	14.4	18.8
10	34.2	44.1	31.7	41.5
15	57.2	61.9	50.7	56

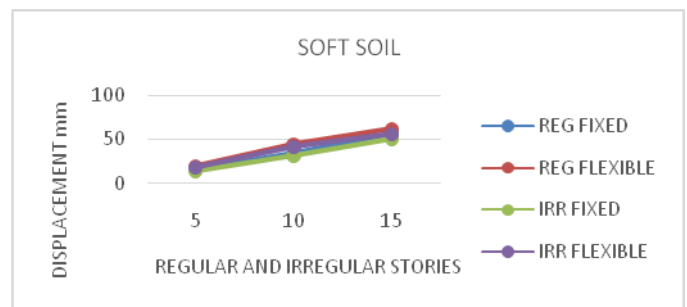

STOREY	REGULAR BUILDING		IRREGULAR BUILDING	
	FIXED	FLEXIBLE	FIXED	FIXED
5	9.1	11.2	8.6	10
10	20.5	24.2	19	22.4
15	34.1	35.1	30.4	31.8

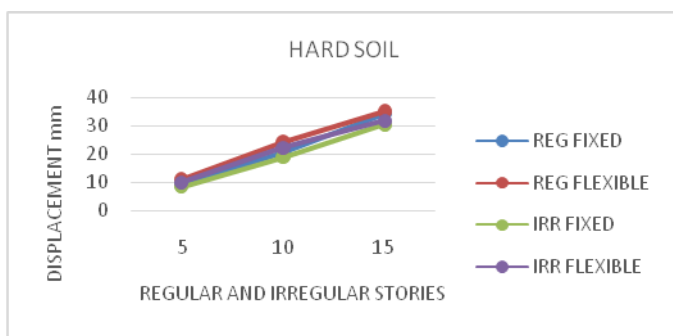

STOREY	REGULAR BUILDING		IRREGULAR BUILDING	
	FIXED	FLEXIBLE	FIXED	FIXED
5	0.8706	1.1196	0.8817	1.1257
10	1.8335	2.1496	1.8599	2.2514
15	2.9061	2.9779	2.9948	3.0931

STOREY	REGULAR BUILDING		IRREGULAR BUILDING	
	FIXED	FLEXIBLE	FIXED	FIXED
5	12.4	15	11.8	14
10	27.8	37.4	25.9	29.9
15	46.4	48.4	41.3	43.6

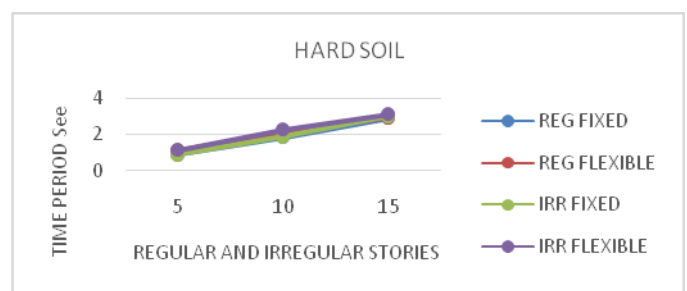

STOREY	REGULAR BUILDING	IRREGULAR BUILDING
--------	------------------	--------------------

	FIXED	FLEXIBLE	FIXED	FIXED
5	0.8706	1.087	0.8817	1.1397
10	1.8335	2.4068	1.8599	2.1959
15	2.9061	3.0104	2.9948	3.1314

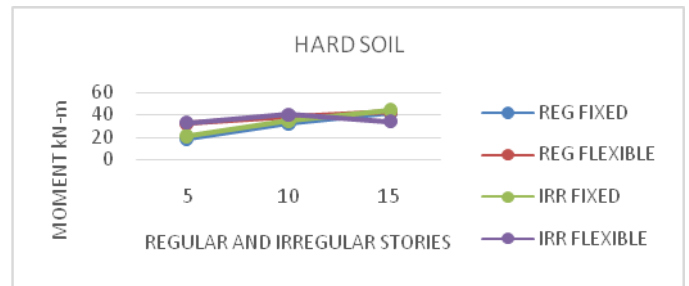

STOREY	REGULAR BUILDING		IRREGULAR BUILDING	
	FIXED	FLEXIBLE	FIXED	FIXED
5	18.95	29.92	21.03	33.64
10	32.17	46.06	34.69	39.6
15	41.59	43.45	44.31	34.27

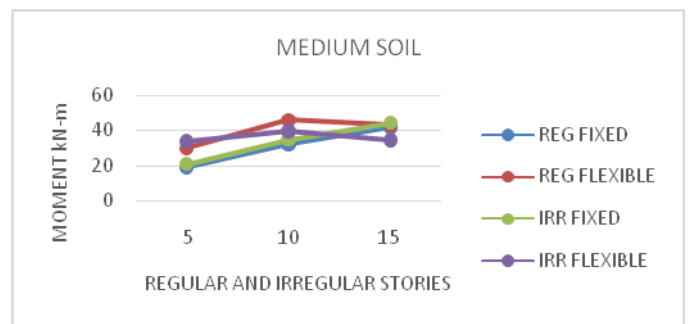
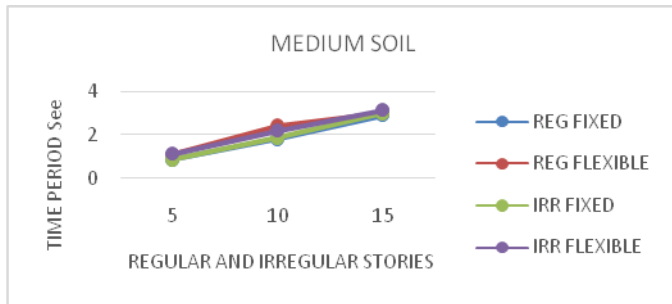

STOREY	REGULAR BUILDING		IRREGULAR BUILDING	
	FIXED	FLEXIBLE	FIXED	FIXED
5	0.8706	1.1758	0.8817	1.2508
10	1.8335	2.2765	1.8599	2.4315
15	2.9061	3.1162	2.9948	3.2466

STOREY	REGULAR BUILDING		IRREGULAR BUILDING	
	FIXED	FLEXIBLE	FIXED	FIXED
5	18.95	35.7	21.03	35.4
10	32.17	30.98	34.69	34.86
15	41.59	43.64	44.31	34.27

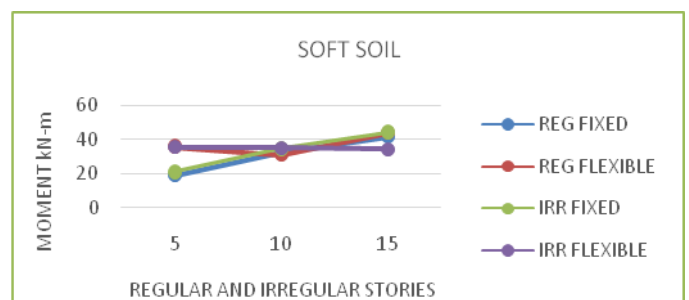
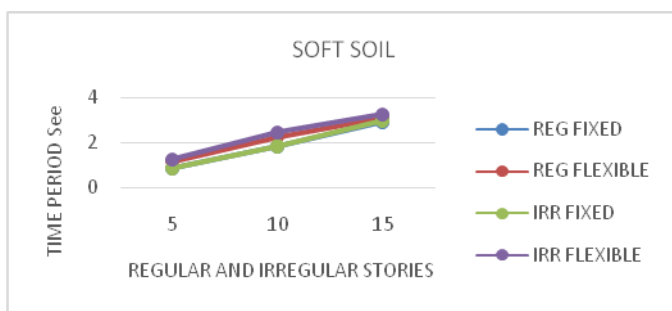

STOREY	REGULAR BUILDING		IRREGULAR BUILDING	
	FIXED	FLEXIBLE	FIXED	FIXED
5	18.95	32.19	21.03	32.84
10	32.17	37.41	34.69	40.22
15	41.59	42.6	44.31	34.27

CHAPTER 7



## CONCLUSIONS AND SCOPE FOR FUTURE STUDY

The present work make an effort to evaluate the effect of Soil Structure Interaction on dynamic characteristic of building frame on isolated footing, mat foundations and pile foundations. The results of the study presiding to the following Conclusions.

- To include the non-linear behavior of the soil by using non-linear springs.
- The analysis can be carried out with Three Dimensional modeling of soil.
- Study may further be extended for different seismic zones.
- Study may further be extended for layered soil.

## 7.1 CONCLUSIONS

- Base shear has reduced for flexible foundation in comparison with fixed base analysis since the natural period increases for flexible base condition.
- There is no much variation in time period for frame model with pile foundation of flexible base in comparison with the fixed base model.
- Framed structure with pile foundation modelled as flexible base shows no difference in Base shear value in comparison with fixed base analysis
- Response of the structure increases with change in soil type from hard to medium and soft irrespective of height of structure and type of foundation.
- Bending moment and displacement increases from fixed base analysis to flexible base analysis, but not much variation for 15 storey frame with pile resting on hard and medium soil. Hence it can be concluded that farmed structure with pile foundation behaves as a fixed support for homogeneous non liquefiable soil.
- Framed structure with pile foundation resting on hard, medium and soft soil can be treated as fixed since no much variation in the response of the structure.
- Famed structure with mat foundation possesses high foundation stiffness in comparison with isolated foundation hence base shear for mat foundation has increased and other parameters like displacement, bending moment and time period have reduced in comparison to structure with isolated footing
- As the height of the structure increases, proportionally the base shear, time period and response also increases. Hence the tall structure supported on soft soil will have more displacement and it needs to be more flexible.
- Framed structure with Irregular and regular plan did not differ much in its response since the percentage of irregularity is less.

## 7.2 SCOPE FOR FUTURE WORK

## REFERENCES

1. **Bryan Stafford Smith and Alex Coull**, "Tall building structures analysis and design", McGillc University Montreal and University of Glasgow Scotlend.
2. **Bhattacharya. K, and Dutta, S.C and Rana Roy**, "Seismic Design Aids for Buildings incorporating Soil-flexibility", Journal of Asian Architecture and Building Engineering, November 2006, pp 341-348.
3. **Ravikumar C M, Babu Narayan K, Sujith B and Venkat Reddy**, "Effect of Irregular Configurations on Seismic Vulnerability of RC Buildings", Department of Civil Engineering, National Institute of Technology, Surathkal.
4. **Bhattacharya. K, and Dutta, S.C**, "Assessing lateral period of building frames incorporating Soil-flexibility", Journal of Sound and Vibration, Dec-2004, pp 795-821.
5. **Parmalee R.A. and J.H.Wronkiewicz**, "Seismic design of soil structure interaction systems", Journal of Structural Div, proceedings of the American Society of Civil Engineers, ST 10, Oct1971,pp -2503-2517.
6. **H. Bolten Seed, J.Lysmer, and R.Hwang**, "Soil structure interaction analysis for seismic response", Journal of geotechnical Engineering Div., GTS, May 1975, pp-439-457.
7. **PrabhatKumar A.D. Pandey, and SharadSharma**"Seismic soil- structure interactionofbuildingsonhillslopes",Journalof Civiland StructuralEngineering, 2011.
8. **Kraus & D. Dzacic**, "Soil-structure interaction effects on seismic behaviour of reinforced concrete frames", JosipJurajStrossmayer University of Osijek, Faculty of Civil Engineering Osijek, Croatia
9. **JeniferPriyanka,R.M.andAnand,N.2012**.Effectoflateralforce ontallbuildingswithdifferenttypeofirregularities.InProceedings oftheINCACMA ConferenceonAdvancesinConstruction, ManufacturingandAutomationResearch

- 10. Dr. S. A. Halkude, Mr. M. G. Kalyanshetti and Mr. S. H. Kalyani**, "Soil Structure Interaction Effect on Seismic Response of R.C. Frames with Isolated Footing", Civil Engg. Dept. Walchand Institute of Technology, Solapur, Solapur University, India Vol. 3 Issue 1, January – 2014
- 11. Agarwal. P. and Shrikhande. M. 2006**, "Earthquake resistant Design of Structures' Prentice-Hall of India Private Limited New Delhi India.
- 12. IS: 456-2000**, "Code of Practice for Plain and Reinforced Concrete", Bureau of Indian Standards, New Delhi, India.
- 13. IS: 1893(part 1): 2002**, "Criteria for Earthquake Resistant Design of Structures", part 1-General provisions and buildings, fifth revision, Bureau of Indian Standards, New Delhi, India.
- 14. Wolf, J.P, Prentice Hall, Englewood Cliffs, N.J., 1985.** "Soil- StructureInteraction"
- 15. SekharChandara Dutta and Rana Roy (2002)**, A Critical Review on Idealization and Modeling for Interaction among Soil-Foundation-Structural System. Vol.80, Computers and Structural Division Page no. 1579-1594.
- 16. Spyracos C.C and ChaojinXu (2003)**, brid FEM-BEM Method for SSI of flexible Strip Foundation embedded in layered soil. Vol.44, Engineering Structures. Page no. 1661-1673.
- 17. Bendigeri Naveen**, "Seismic Evaluation of Soft storey in upper floors of Multistorey RC buildings", M.Tech Thesis Report, B.V.B College of Engineering, Hubli, 2006-2007
- 18. FEMA -356 (2000)** prestandard and commentary for the seismic rehabilitation of buildings, federal emergency management agency, building seismic safety council, Washington, D C.
- 19. SharbonyAdhikary, Yogendrasingh and D. K. Paul**, "Modeling of soil -foundation - structure system", department of earthquake engineering IIT Roorkee.
- 20. Saha. R, Haldar. S and Dutta. S.C**, "Seismic Response of Soil-Pile Foundation-Structure System", School of Infrastructure, IIT Bhubaneswar, Bhubaneswar.