

# Heavy Payload Tethered Hexarotors for Agricultural Applications: Power Supply Design

Wasantha<sup>1</sup>, Guangwei Wang<sup>2</sup> and Shiqin Wang<sup>3\*</sup>

<sup>1,2,3</sup> Center for Agricultural Resources Research, Institute of Genetics and Developmental Biology, Chinese Academy of Sciences, 286 Huaizhong Road, Shijiazhuang, Hebei, P. R. of China.

\*Correspondence: Shiqin Wang, E-mail: sqwang@sjziam.ac.cn

\*\*\*

**Abstract** - *This research paper addresses the design problem of heavy payload tethered hexarotor for agricultural applications where payload requirements are high, low altitude long time hovering is expected. Tethered hexarotors are unmanned aerial vehicles with ability of vertical takeoffs, landings and hovering at desired location. Since the vehicle is tethered it has no flight time restrictions that the battery operated unmanned aerial vehicles has, and suitable for long time uninterrupted data acquisition tasks, while meeting requirements such as ability to provide power for data acquisition device and other related equipment operation. In this paper we mainly introduce in detail the power supply design of aerial vehicle and ground power supply station. Since the objective discipline is agricultural automation and remote sensing, the proposed design should be all terrain and has ability to operate under certain degree of rough weather as possible. In existing tethered hexarotors the payload thresholds are typically lower due to the vehicle body design, the weight of power conversion devices and relevant issues. Another fact is many popular hexarotors are not carefully designed to meet with reliability for industry use. Payload and available power capacity to data acquisition device are key factors in planning flight missions. Since one of our previous prototype has proven success to lift 30kg payload, in this research we evolve the vehicle design to be more practical and to become a good platform for future applications.*

**Key Words:** *Tethered Hexarotors, Heavy Payload UAV, UAV for Agricultural Applications, Power Supply for Tethered UAV*

## 1. INTRODUCTION

Using unmanned aerial vehicles (UAV) in scientific missions is quite popular topic of interest in scientific

research community. Battery powered unmanned aerial vehicles for hobby use like aerial photography is very common today. Flight time of a battery operated flight of hexarotors is a bottleneck for real world application scenarios. There are few attempts on solving this problem with automated battery changing systems so far, but incomparable with shifting to tethered.

As an introduction of hexarotors (multirotor with six propellers) are sub group of unmanned aerial vehicles (UAV) used widely due to their reliability. Applications are vary from simple photographical use to advanced scientific missions such as model building, data acquisition. As a good interdisciplinary application of UAV's is described in [5] by Mark W. Bailey. Another impressive application is introduced in [1] by David Copenhaver and Frank Woodward an application of a tethered UAS for urban firefighting scenario. In [2] Chung Deng et al. Illustrates strategic use of 10kg class tethered UAV for communication. However there aren't much evidences for tethered multirotors for payloads higher than 20kg operating at present. The development of tethered UAVs are costly and complex comparing to battery operated UAVs.

Battery operated vehicles has to be replaced with tethered vehicles where longer flight missions in low altitude and high payloads are expected. This is further true when it comes to the issue that data acquisition device which is mounted on the aerial vehicle needs more power to operate than battery could supply to.

Considering the above facts and technical backgrounds and achievements so far as illustrated in [7] this ongoing research can be considered as a good solution for missions that requiring longer flight time and heavy payload, i.e. industry class missions in agricultural automation and remote sensing. This includes missions where uninterrupted operation is required i.e. such as avoid data loss during return the vehicle for battery

changing location unless properly designed. This is the reason that tethered vehicles are used as base stations. One such example is illustrated in [2] by Chung Deng et al.

Since the target discipline is agricultural automation and remote sensing, the proposed design should be all terrain, i.e. has ability to operate under certain degree of rough weather as possible.

In the following sections we describe in detail about power supply system of UAV, ground power supply and monitoring station and other related features.

## 2. POWER SUPPLY SYSTEM

As illustrated in figure 1 the power system consist of the following parts.

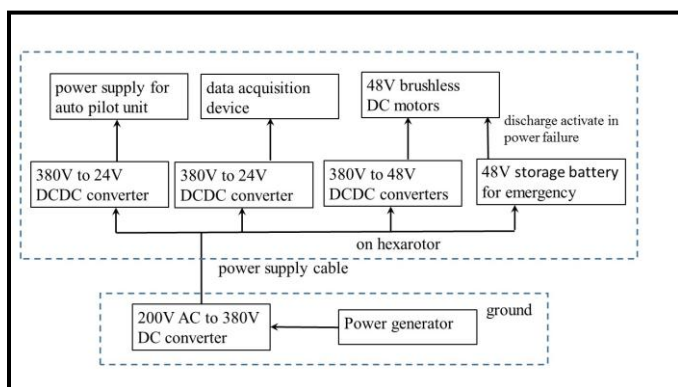

Fig-1: Power Supply System of Tethered Hexarotor

On ground power supply and monitoring station we have following units.

- (1) Power generator (30KW range, 200VAC, 3 phase depending on the operation height of the vehicle)
- (2) ACDC conversion unit (200VAC to 380VDC)
- (3) Cable winding structure (motor driven as in [7])
- (4) Landing doc for hexarotor

A typical layout for a power generation and ACDC conversion unit with an automated cable winding structure is illustrated in figure 2. Landing doc is opted in the figure for visibility.

On aerial vehicle we have following units,

- (1) 380VDC to 48VDC converters for brushless DC motors

- (2) 380VDC to 24VDC converters for data acquisition device

- (3) 380VDC to 24VDC converter for autopilot unit

- (4) 48VDC storage battery for emergency landing and related monitoring circuits to charge the 48V batteries and trigger discharging during a power loss.

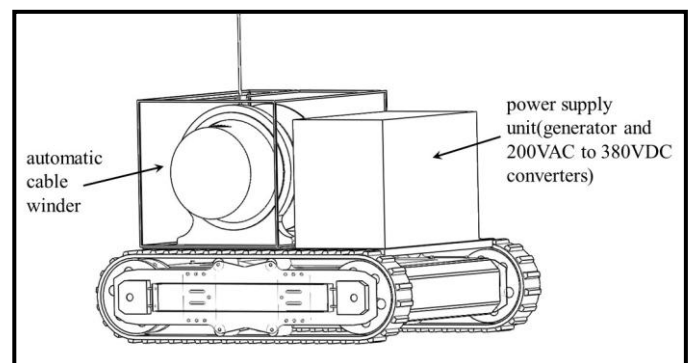

Fig-2: Typical ground power supply and a conversion unit on tank tracks.

Since the proposed system should be operated in rough terrains, it is preferred to be mounted on tank tracks or all terrain ground vehicle. The following are some background developments and prospects of 380VDC tethered UAV power supply.

To reduce power loss between power supply unit on ground and tethered aerial vehicle it is necessary to apply high voltage. The higher the voltage in the supply cable, the lower the power loss and the power supply cable becomes light weighted. In this research the aerial vehicle is operated using 48V direct current (DC). The power source is 200V three phase alternate current (AC) from power generator. Thus the power transmission is done using 380V direct current, which is not typical high voltage. But considering the low voltage used in popular radio controlled (denotes RC) 380V as a high voltage comparing to the operation voltages of brushless DC motors, hence denotes as high voltage during this paper.

High voltage direct current (HVDC) power supply is gaining its popularity due to reliability and effectiveness in long distance power transmissions. This is a fact that many power efficiency requested places are switching to HVDC as possible, such as data centers as illustrated in [3] by Akiyoshi Fukui et al. and in [4]. However when it comes to aerial vehicles the developing light weighted reliable

motors and motor drivers for high voltages is still a long research goal. There are few recent news about such developments but still not powerful enough for field operations so far. Therefore in our vehicle design we adopt 380V to 48V DCDC conversion to reduce power loss.

### 3. POWER CONVERSION ON UAV

The power conversion unit mounted on UAV consists of following parts as illustrated in figure 3 below.

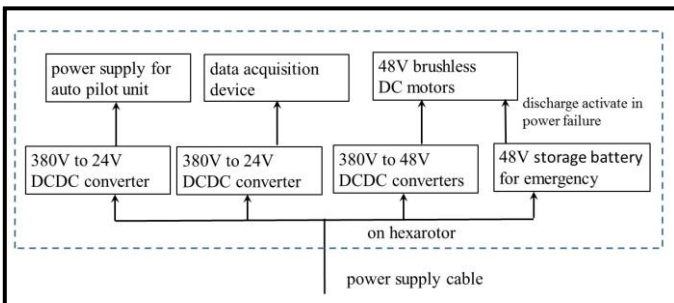

Fig-3: Power Conversion Unit on UAV

The major part of the power conversion is 380VDC to 48VDC converters for hexarotor motors. The main issue with the 380VDC to 48VDC conversion on aerial vehicle is the weight of the converter and the peak current per converter. Prevention of overheating of DCDC converters is a key factor in designing the vehicle, i.e. unless properly designed the converter itself and converter placement in vehicle design, the tradeoff issues occur at maximum thrust or sudden cutout of current supply to a specific motor at lower thrust than expected threshold values. To solve this overheating problem we use fans for ventilation.

During this research DCDC converter itself is custom designed to be of light weighted and compact than existing approaches (achieved 160g in our new design against conventional design of 680g per converter). Also the parallel use of high power density bus converters allow us to lift existing power thresholds to motors. This feature is explained in figure 4. However the converters are still bulky and the design has to be evolve up to card type interface with built in heatsinks in future. Figure 4 is from a previous version as in [7], which is per motor placement. In this new design we apply low voltage bus bar for power balancing and apply full parallel placement as illustrated in figure 5. We use isolation for 380VDC connector bar from other parts by placing in separate box.

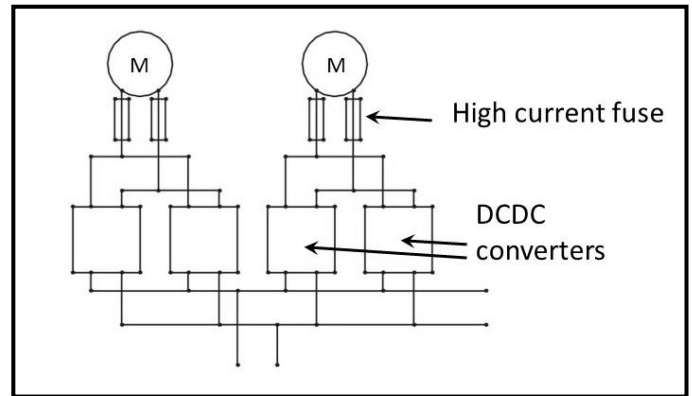

Fig-4: 380V to 48V DCDC Converters Connected to Motors (Previous Version)

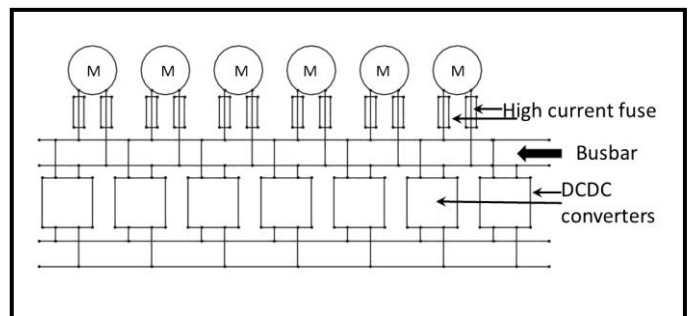

Fig-5: 380V to 48V DCDC Converters Connected to Motors (This Approach)

Considering the technical facts above we reengineered the power conversion unit to be as illustrated in figure 6.

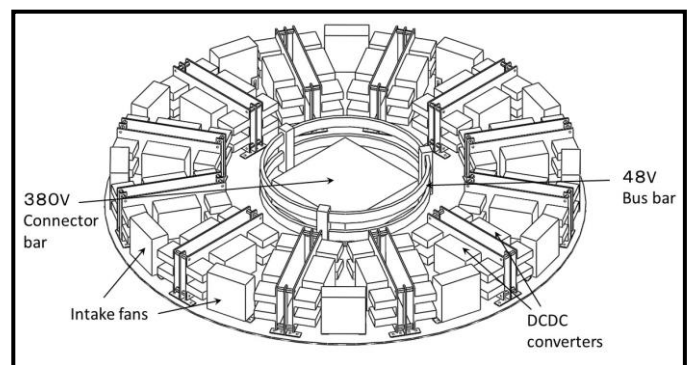

Fig-6: The Proposed Power Conversion Unit for UAV

The ventilation process is an important factor when design the unit to be for practical use, i.e. operate in field operations. The airflow within the proposed unit is illustrated in figure 7. Figure 8 illustrates a use of exhaust fan as a ventilator unit.



Fig-7 Airflow within the Power Conversion Unit

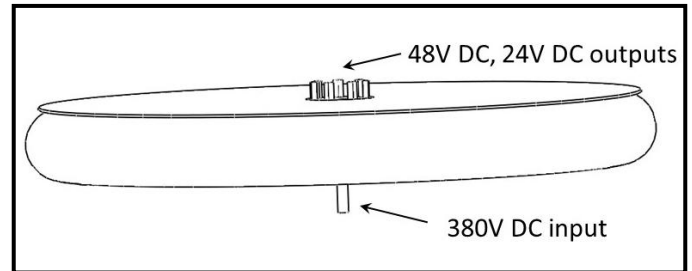

Fig-10: The Proposed Unit (outcome of design)

Finally we illustrates the new prototype of tethered hexarotor used for agricultural missions bellow as in figure 11.

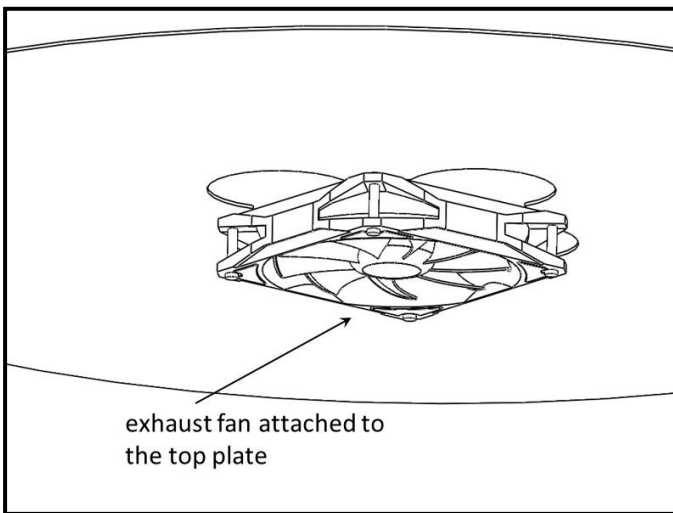

Fig-8: Exhaust Fan as a Ventilator

In addition to above components power conversion unit has 380VDC to 24V dc converters for device operation and UAV autopilot use. Figure 9 illustrates the overall unit and figure 10 illustrates the outcome of the design.

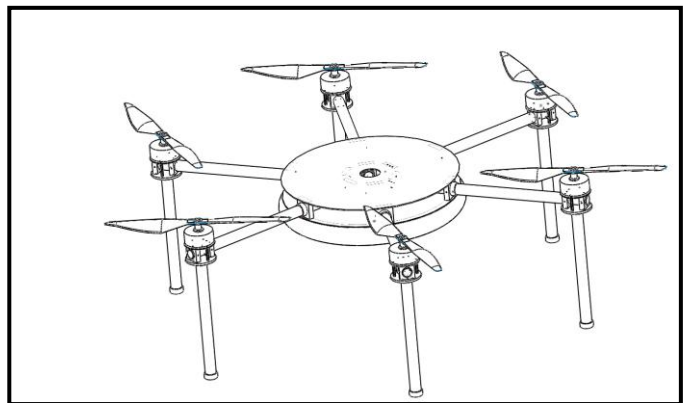

Fig-11: Tethered Hexarotor in this Design

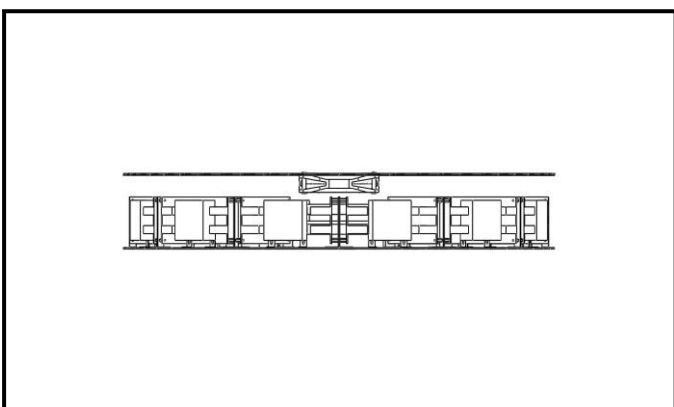

Fig-9: The Proposed Unit

48VDC storage battery for emergency landing and related circuits are not placed inside the power conversion unit, rather connected to each motor, hence placed outside the power conversion unit.

#### 4. CONCLUSIONS

This paper briefly introduced the power supply design for heavy payload tethered hexarotors for agricultural applications. Since the payload requirements for the hexarotor is heavy as 30kg, longer flight missions and ability to operate under certain degree of rough weather as possible are prerequisites, the proposed design became unique and challenging design. The proposed unit shows no excessive heat and power defects so far.

#### REFERENCES

- [1] David Copenhaver, Frank Woodward, "Unmanned Aerial Systems – Urban Firefighting’s next tool?", "http://www.ipsnexgen.com/docs/NexGen\_Firefighting\_Article.pdf", 2014/10/19.
- [2] Chung Deng, Sheng Wei Wang, Zhi Huang, Zhong Fu Tan and Jun Yong Liu, "Unmanned Aerial Vehicles for Power Line Inspection: A Cooperative Way in Platforms and Communications", Journal of Communications, Volume 9, No. 9, September 2014.



- [3] Akiyoshi Fukui, Takashi Takeda, Keiichi Hirose, and Mikio Yamasaki, "HVDC Power Distribution Systems for Telecom Sites and Data Centers", The 2010 International Power Electronics Conference, pp874-880.
- [4] "World's most powerful DC data center online: ABB and Green launch state-of-the-art data center employing HP servers for new levels of efficiency and reliability",  
Pressrelease,"<http://www.abb.com/cawp/seitp202/187b2f29acaea090c1257a0e0029fb1a.aspx>",  
2014/10/30.
- [5] Mark W. Bailey, "Unmanned Aerial Vehicle Path Planning and Image Processing for Orthoimagery and Digital Surface Model Generation", Master of Science Thesis, Graduate School of Vanderbilt University, Nashville, Tennessee, U.S.A., December 2012.
- [6] Roopa. J and Govinda Raju. M, "Design & Implementation of Closed Loop PID Mechanism for wire Tension Control in Winding Machine", International Journal of Mechanical and Industrial Engineering (IJMIE) , Volume 1, Issue 2, 2001, pp36-41.
- [7] Wasantha Samarathunga, Guangwei Wang and Shiqin Wang, "Vehicle Design of Tethered Hexarotors for Heavy Payload Applications"2015 IEEE International Conference on Computational Intelligence & Communication Technology, Jan 2015, Paris. pp 554-556.