

Estimation of speed and Parameter identification in Sensorless IM drive By using Second order Sliding-mode Observer and MRAS techniques

M. Anka Rao¹, Dr. M. Vijaya Kumar², B. Mukteswari³

¹ Assistant professor, Department of EEE, JNTU Anantapur, Andhra Pradesh, India

² professor, Department of EEE, JNTU Anantapur, Andhra Pradesh, India

³ Student, Department of EEE, JNTU Anantapur, Andhra Pradesh, India

Abstract- This paper presents a comparative study of performance of sensor and sensorless IFO IM drives. In case of operation of drives with sensors, has good dynamic performance at high and medium speed operation. Where as at low speed operation, the performance of the drive is not satisfactory. To get satisfactory performance even at low speeds sensorless controlled IM drives with MRAS and Sliding mode observer is designed. Sensorless control has good dynamic response compared to drives with sensor. In a sensorless induction motor drive, A Stator current observer is designed based on the second-order sliding mode which is used as the reference model of the MRAS estimator. The phase angle error between the actual and estimated rotor flux vectors is used to tune the adaptive model of MRAS estimator. The sliding mode observer is insensitive to variation of stator resistance, rotor resistance and perturbation when the states arrive the sliding mode. By making full use of auxiliary sliding-mode surfaces, the proposed observer successfully reduces the chattering behavior. Furthermore, in order to improve the near zero speed operation, a parallel adaptive identification of stator resistance is designed based on derivatives of rotor flux and stator current.

Key Words: Induction motors (IMs), model reference adaptive system (MRAS) estimator, supertwisting algorithm Sensorless control, second order sliding mode, parameter estimation, Low speed operation.

1.INTRODUCTION

Now-a-days induction motors (IM) have replaced DC motors in the industrial applications. High performance sensorless induction motor drives have attracted a great attention in industrial applications due to their

advantages such as low cost, less maintenance, and high reliability etc. The sensorless control helps to reduce the cost and resolves installing problems in many applications. There are many different ways to drive an induction motor. The Differences between them are the performance of motor and the cost of implementation. At present efforts are devoted to improve the performance of observer at low speeds, and to develop a robust observer against perturbations and variation of parameters.

Several methods have been proposed to estimate speed and flux of IM such as: Luenberger observer and kalman filter, high gain and adaptive observers, neural networks and signal injection, and sliding mode observer etc. Compared with the other methods, sliding mode techniques has attractive advantage of robustness to disturbances and insensitive to parameter variation when the sliding mode is reached. However, the chattering behavior, that is inherent in standard sliding mode techniques, is often an obstacle for practical applications if neglected. Higher order sliding mode is one of the solutions which does not compromise robustness and avoids filtering estimation considered by other methods.

An improved rotor flux based model reference adaptive system (MRAS) scheme with a parallel rotor speed and stator resistance estimation algorithm is considered. Both the differences in instantaneous phase and amplitudes are used for speed estimation and stator resistance (R_s) identification. In addition, the mismatch of rotor resistance (R_r) introduces errors to the estimated speed in wide speed range operation. Compared with R_s , rotor resistance is more difficult to be identified online since the parallel estimation of speed and rotor resistance is possible only if rotor flux

varies, which is not the case in steady state. Since the rotor inductance L_r can be treated as a constant, the rotor time constant identification is equivalent to the R_r identification. So far numerous online parameter estimation techniques have been proposed on the basis of existing speed estimation schemes, which are able to improve dynamic characteristics and noise immunity, as well as insensitivity to parameter variations. In this scheme, both rotor speed and rotor time constant can be estimated by a sliding function based on a second-order system.

Extended kalman filters (EKF) based estimation scheme has significantly increased the accuracy of the estimation of the estimation of the stator and rotor resistances. However, they have no specific tuning criteria. Sliding mode observers are recognized for their robustness against parameter variations, yet they suffer from chattering behavior at the same. By using auxiliary sliding mode surface chattering behavior can be reduced.

2. SVM BASED INDIRECT VECTOR CONTROLLED IM DRIVE

Several speed estimation techniques are available, for IM drives. In this case performance of indirect field oriented controlled IM drive specially at low speeds is studied. Simulink diagram of SVM based indirect vector controlled induction motor drive is shown in fig.1.

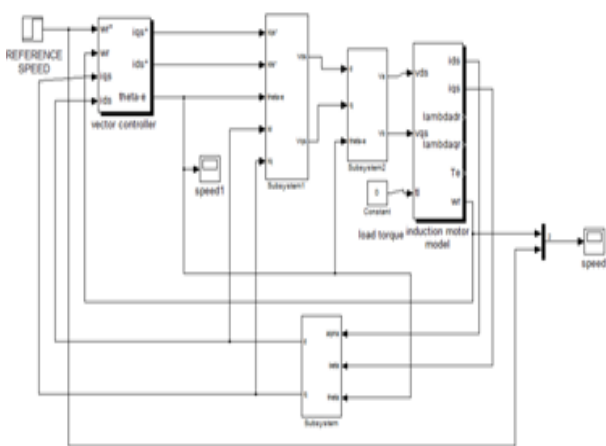

Fig:1 Simulink diagram of IFO IM Drive

This proposed model has good dynamic performance and gives excellent results during high and medium speed operation. But When the drive is operated at low speeds performance of the drive is not satisfactory. To

overcome the above disadvantage, Sensorless Induction motor drive is designed by using second order sliding mode observer. Sliding mode observer is robust to perturbations and insensitive to parameter variation. In order to improve near zero speed operation, a parallel adaptive identification of stator resistance is designed based on derivatives of rotor flux and stator current.

2.2 Operation of drive at low speeds

Stator resistance estimation plays an important role in low speed estimation, since the mismatch between the actual value and set value may lead not only to a speed estimation error but also to system instability.

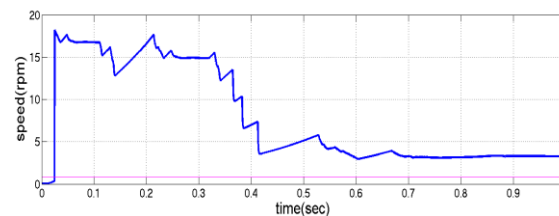

Fig:2 Estimated speed for reference speed of 10 rpm.

In this method, stator resistance estimation is not possible, consequently operation at low speeds may lead to unstable operation. An improved speed estimation method (especially at low speeds) by using MRAS estimator and sliding mode techniques is discussed in the following case.

3. SENSORLESS IM DRIVE BY USING MRAS AND SLIDING MODE OBSERVER

3.1. second-order smo

The IM in stationary reference frame (α, β) in terms of stator current and rotor flux can be written as follows

$$\begin{cases} p i_{s\alpha} = -(k_1, k_2 + R_s, k_3) i_{s\alpha} + k_3 \cdot u_{s\alpha} \\ \quad + k_2 (\psi_{r\alpha} / T_r + w_r \cdot \psi_{r\beta}) \\ p i_{s\beta} = -(k_1, k_2 + R_s, k_3) i_{s\beta} + k_3 \cdot u_{s\beta} \\ \quad + k_2 (\psi_{r\beta} / T_r - w_r \cdot \psi_{r\alpha}) \\ p \psi_{r\alpha} = k_1 i_{s\alpha} - \psi_{r\alpha} / T_r - w_r \psi_{r\beta} \\ p \psi_{r\beta} = k_1 i_{s\beta} - \psi_{r\beta} / T_r + w_r \psi_{r\alpha} \end{cases} \dots (1)$$

where

$$\sigma = 1 - L_m^2 / (L_s L_r) \quad k_1 = L_m / T_r$$

$$k_2 = L_m / (\sigma L_s L_r) \quad k_3 = 1 / (\sigma L_s)$$

And $i_{s\alpha}, i_{s\beta}, \psi_{r\alpha}, \psi_{r\beta}$ and $u_{s\alpha}, u_{s\beta}$ are respectively stator currents, rotor fluxes, and stator voltages w_r is the angular velocity. R_s and R_r are the stator and rotor resistances. L_s and L_r are respectively the stator and rotor inductance. L_m is the mutual inductance. σ is the leakage coefficient. T_r is the rotor time constant.

3.2. supertwisting algorithm(STA)

Supertwisting algorithm is generally used in second order sliding mode observer. The finite time convergence and robustness of STA have been proved by geometrical methods, and the continuous stability of STA has been proved by Lyapunov methods. The simplest form of STA can be written as

$$\begin{cases} p\hat{x}_1 = f(\hat{x}_2) + \lambda|x_1 - \hat{x}_1|^{0.5} \cdot \text{sgn}(x_1 - \hat{x}_1) + \rho_1 \dots (2) \\ p\hat{x}_2 = \delta \cdot \text{sgn}(x_1 - \hat{x}_1) + \rho_2 \end{cases}$$

where x_i denotes the state variables, λ and δ are switching gains, and ρ_i represents the perturbation terms. According to Levant and moreno and osorio, it is well known that the STA is robustly stable to perturbations globally bounded by

$$\rho_1 = 0, \quad |\rho_2| \leq L$$

For any positive constant L the gains are approximately selected.

3.3 STA-based observer

The third and fourth terms of (1) can be substituted into the first and second terms; thus(1) is rewritten as

$$\begin{cases} pi_{s\alpha} = -R_s \cdot k_3 i_{s\alpha} - k_2 \cdot p\psi_{r\alpha} + k_3 \cdot u_{s\alpha} \\ pi_{s\beta} = -R_s \cdot k_3 i_{s\beta} - k_2 \cdot p\psi_{r\beta} + k_3 \cdot u_{s\beta} \\ p\psi_{r\alpha} = k_1 i_{s\alpha} - \psi_{r\alpha} / T_r - w_r \psi_{r\beta} \\ p\psi_{r\beta} = k_1 i_{s\beta} - \psi_{r\beta} / T_r + w_r \psi_{r\alpha} \end{cases} \dots (3)$$

considering a variable substitution

$$\begin{cases} z_1 = i_{s\alpha} \\ z_2 = i_{s\beta} \end{cases} \begin{cases} z_3 = -p\psi_{r\alpha} \\ z_4 = -p\psi_{r\beta} \end{cases} \dots (4)$$

Where $z_1 - z_4$ are the intermediate variables Substituting (4) into (3) yields

$$\begin{cases} pz_1 = -R_s \cdot k_3 \cdot z_1 + k_2 \cdot z_3 + k_3 \cdot u_{s\alpha} \\ pz_2 = -R_s \cdot k_3 \cdot z_2 + k_2 \cdot z_4 + k_3 \cdot u_{s\beta} \end{cases} \dots (5)$$

By applying the STA to the IM model (2), a current observer can be constructed as

$$\begin{cases} p\hat{z}_1 = -R_s \cdot k_3 \cdot \hat{z}_1 + k_2 \cdot \hat{z}_3 + k_3 \cdot u_{s\alpha} \\ \quad + \lambda_1 \cdot |e_1|^{0.5} \cdot \text{sgn}(e_1) \\ p\hat{z}_2 = \delta_1 \cdot \text{sgn}(e_1) \end{cases} \dots (6)$$

$$\begin{cases} p\hat{z}_3 = -R_s \cdot k_3 \cdot \hat{z}_2 + k_2 \cdot \hat{z}_4 + k_3 \cdot u_{s\beta} \\ \quad + \lambda_2 \cdot |e_2|^{0.5} \cdot \text{sgn}(e_2) \\ p\hat{z}_4 = \delta_2 \cdot \text{sgn}(e_2) \end{cases} \dots (7)$$

Where $\hat{z}_1, \hat{z}_2, \hat{z}_3, \hat{z}_4$ are the observations.

λ_1, λ_2 and δ_1, δ_2 are respectively the gains of the primary and auxiliary sliding-mode surfaces. $\text{sgn}()$ represents the sign function. e_1 and e_2 are the errors, which are defined as $e_1 = z_1 - \hat{z}_1$ and $e_2 = z_2 - \hat{z}_2$. R_s, k_2 , and k_3 are treated as constants in the observer.

According to (4), there exists a simple relation between the observations \hat{z}_3 and \hat{z}_4 and the derivatives of rotor flux

$$\begin{pmatrix} -\hat{z}_3 \\ -\hat{z}_4 \end{pmatrix} = \begin{pmatrix} p\hat{\psi}_{r\alpha} \\ p\hat{\psi}_{r\beta} \end{pmatrix} = p\hat{\psi}_r^z \dots (8)$$

where $p\hat{\psi}_r^z = [p\hat{\psi}_{r\alpha}^z \ p\hat{\psi}_{r\beta}^z]^T$ represents the estimated results with the physical significance of "derivatives of rotor flux."

3.4 proposed observer with perturbation

Equations (6) and (7) are decoupled, so their disturbance characteristics can be analysed independently. Considering (6) only and taking parameter variation into consideration, we get the following form

$$\begin{cases} p\hat{z}_1 = -R_s \cdot k_3 \cdot \hat{z}_1 + k_2 \cdot \hat{z}_3 + k_3 \cdot u_{s\alpha} \\ \quad + \lambda_1 \cdot |e_1|^{0.5} \cdot \text{sgn}(e_1) + \rho_{z1} \\ p\hat{z}_2 = \delta_1 \cdot \text{sgn}(e_1) + \rho_{z2} \end{cases} \dots (9)$$

The perturbation caused by variation of the stator parameter can be converted into ρ_{z1} . Similarly, ρ_{z2} represents the perturbation caused by the variation of the rotor parameter.

According to STA, for every positive value of L there exist such gains λ_1 and δ_1 that the observations of (9), i.e., \hat{z}_1 and \hat{z}_2 are robust against perturbation $\rho_{z3} \leq L$.

STA based observer is sensitive to ρ_{z1} , which is primarily composed of the variation of R_s . R_s identification plays an important role in low speed estimation since the

mismatch between the actual value and set value may lead not only to a speed estimation error but also to system instability. On the other hand R_s can still be treated as constant in (6) and (7) because it varies slowly compared to electrical signal.

In discrete time, the kth observation error is calculated by $e(k)=z(k)-\hat{z}(k)$, where $z(k)$ is real component, $\hat{z}(k)$ is estimated one. Thus, $e(k-1)$ is the (k-1)th observation error, which is used to calculate the estimated $\hat{z}(k)$.

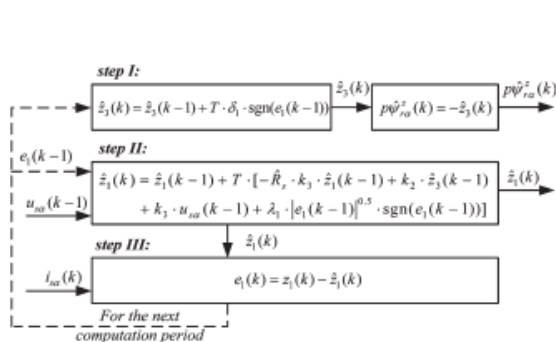

Fig-3:Flowchart of discrete-time STA based observer

If the gains are selected according to the conditions that they presented, the error states are ultimately bounded. In other words, the trajectories of system enter into a boundary layer in the vicinity of the sliding mode and stay inside it forever. This algorithm is termed as supertwisting-like algorithm. For The continuous second-order SMO shown in (6) and (7) the discrete observer is obtained. The gains of the discrete STA based observer should satisfy the necessary and sufficient conditions for the existence of the sliding-mode hyperplane in discrete time. The conditons were obtained by using Lyapunov function.

$$V_k = e^2(k) \quad \dots (10)$$

$$\Delta V_k = e^2(k+1) - e^2(k)$$

The necessary and sufficient conditions to ensure the sliding motion on the hyperplane are obtained

$$[e(k+1)-e(k)] \cdot \text{sgn}(e(k)) < 0$$

4 SPEED ESTIMATION SCHEME

4.1. Standard MRAS speed estimator

MRAS speed estimation makes use of two machine models with different structures that estimate the same motor state. The motor states may be rotor flux, back emf

or reactive power etc. Choosing the rotor flux to be the state, the estimation error can be $\mathcal{E} = \psi_{r\alpha}^i \psi_{r\beta} - \psi_{r\beta}^i \psi_{r\alpha} \dots (11)$

The phase angle error between actual and estimated rotor flux vectors is used to tune the speed as is illustrated in fig.4.

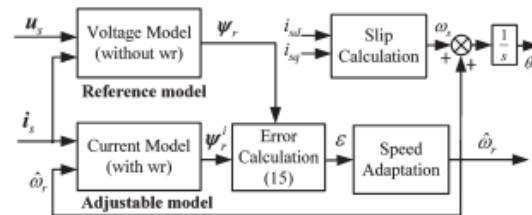

Fig-4:Block diagram of standard rotor based MRAS estimator.

4.2. Proposed MRAS speed estimator

In proposed estimator derivatives of rotor flux is used as state, an adaptive mechanism of speed based on these observations is required. For speed estimation, the output of reference model is regarded as equal to the actual rotor flux vector, and Hence

$$p e_{\psi}^i = \begin{bmatrix} p\psi_{r\alpha}^i - p\hat{\psi}_{r\alpha}^i \\ p\psi_{r\beta}^i - p\hat{\psi}_{r\beta}^i \end{bmatrix} \begin{bmatrix} p\hat{\psi}_{r\alpha}^z - p\hat{\psi}_{r\alpha}^i \\ p\hat{\psi}_{r\beta}^z - p\hat{\psi}_{r\beta}^i \end{bmatrix} \quad \dots (12)$$

Eventually the estimation equation of rotorspeed is

$$\hat{\omega}_r = (k_p + k_i/p) \cdot e_w \quad \dots (13)$$

where

$$e_w = -p\hat{\psi}_{r\alpha}^z \cdot p\hat{\psi}_{r\beta}^i + p\hat{\psi}_{r\beta}^z \cdot p\hat{\psi}_{r\alpha}^i \quad \dots (14)$$

Compared with the standard MRAS speed estimation, the proposed speed estimator eliminates the integrators, thus simplifying the system and avoiding the problems caused by integration.

4.3 Parallel R_s identification

Stator resistance (R_s) plays an important role in low-speed estimation since the mismatch between the actual value and set value may lead not only to a speed estimation error but also to system instability. The offline estimation of R_s is not sufficient because the actual value varies due to complex reasons, such as temperature. Parallel R_s estimation is based on derivatives of rotor

flux. In case of parallel R_s estimation reference model and adjustable model exchange their roles.

Symbols ψ_r^z and $\hat{\psi}_r^z$ respectively stand for actual and estimated rotor flux vectors of voltage model

The voltage model of IM can be written as

$$p\psi_r^z = \frac{L_r}{L_m} [u_s - (R_s \cdot i_s + \sigma L_s \cdot p i_s)] \quad \dots (15)$$

The observer equation is

$$p\hat{\psi}_r^z = \frac{L_r}{L_m} [u_s - (R_s \cdot \hat{i}_s + \sigma L_s \cdot p \hat{i}_s)] \quad \dots (16)$$

When the estimation error trajectory reaches the sliding mode, we get $\hat{i}_s = i_s$ Eventually the estimation of stator resistance obtained as

$$\hat{R}_s = (k_p + k_i/p) \cdot e_R \quad \dots (17)$$

where

$$e_R = \hat{z}_1 \cdot (p\hat{\psi}_{r\alpha}^z - p\hat{\psi}_{r\alpha}^i) + \hat{z}_2 (p\hat{\psi}_{r\beta}^z - p\hat{\psi}_{r\beta}^i) \dots (18)$$

R_s is treated as constant in the STA-based observer because it changes much slower than electric signals such as stator voltage and current.

4.4.SSM scheme

The proposed SSM scheme used in this paper is a combination of STA-based SMO and MRAS estimator which is named as SSM scheme. The configuration of the SSM scheme is shown in fig.5.

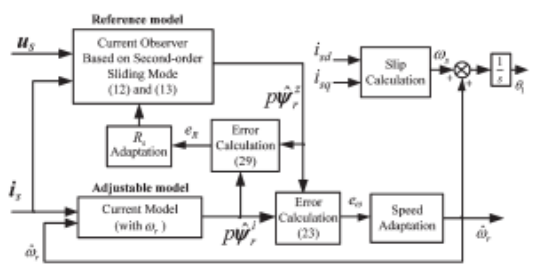

Fig-5:Block diagram of the proposed SSM scheme

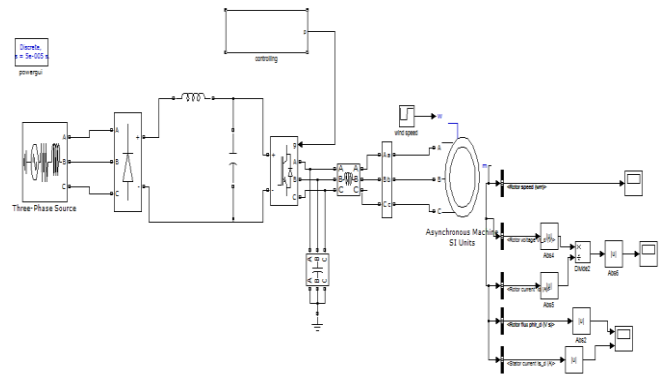

Fig-6:simulink diagram of sensorless IM drive

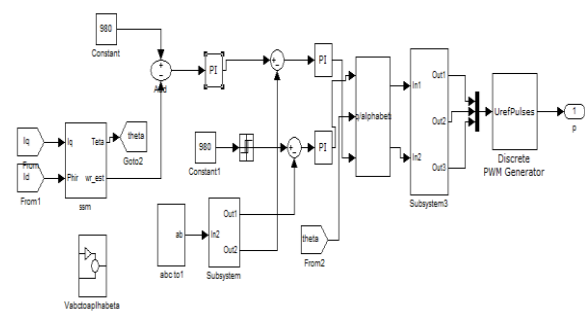

Fig-7:Simulink diagram of controlling technique

TABLE 1
PARAMETERS OF THE IM DRIVE

Parameter Value	Parameter	Value
Rated power(kw) 15	Stator resistance(Ω)	1.556
Rated voltage(V) 380	Rotor resistance(Ω)	1.31
Rated current(A) 18.5	Stator inductance(mH)	0.156
Rated speed(rpm) 980	Rotor inductance(mH)	0.162
Rated frequency(Hz) 50	Mutual inductance(mH)	0.15
Number of poles 3	Inertia(kg·m ²)	0.06

The mathematical model of IM is built according to the rated parameters given in Table1

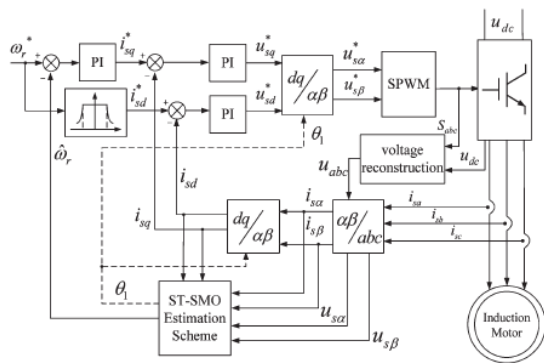

Fig-8: Block diagram of sensorless IFO controlled IM drive

5.SIMULATION RESULTS

The proposed scheme is verified by simulation. The Simulink model of sensorless indirect field oriented controlled IM drive is shown in fig.6.

The pulse width modulation (PWM) frequency is set to 10 kHz, which is the same frequency as the sampling rate of the SSM scheme. The motor phase voltages are reconstructed relying on the dc voltage and PWM duty cycles. The gains are set to

$$\lambda_1 = \lambda_2 = 6000 \text{ and } \delta_1 = \delta_2 = 40000$$

which satisfies the limits discussed in section2.

5.1 Low speed operation

The performance of parallel R_s identification is tested in low speed operation. Which is shown in fig.9. In this case the machine is operating with a torque of 20-N.m load at speed 10 rpm, and the actual R_s is sharply increased from 1.6 to 2.1 Ω at t=3sec, the estimated R_s value keeps in step with the actual one, thus consequently eliminating the initial speed estimation error.

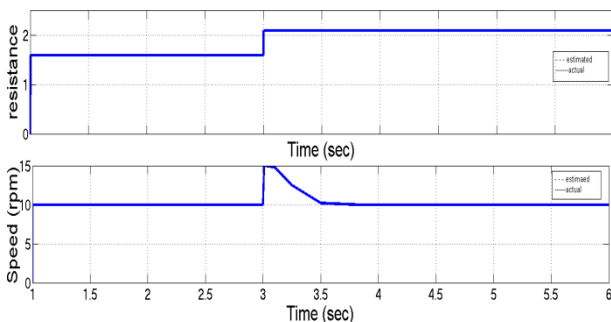

Fig-9: Speed estimation and stator R_s resistance estimation at speed command of 10 rpm and sharp variation of stator resistance

5.2 Observability verification

The IM motor observability cannot be established in the particular case when the rotor fluxes and the speed are constant. Operation of drive in this case can be represented as unobservability curve. It is significant to verify the performance of the proposed SSM scheme in one point of the unobservability curve. The SSM scheme is tested in open loop in order to achieve the particular case. The test rotor flux is set to 1.5 Wb, and the load is 50 Nm. According to the unobservability curve, an angular speed of -3.21 rps corresponds to the condition of loss of observability.

In fig.10 the IM is tested with an initial speed of 20 rps and a 50 Nm load (start at 0.5sec and ready at 0.7sec), followed by a speed of 80 rps (from 2sec to 3 sec), then by a speed of -3.21rps (from 4sec to 5sec), and finally by a speed of 25 rps (from 6 to 7). The simulation result show that the proposed scheme is stable under unobservable conditions.

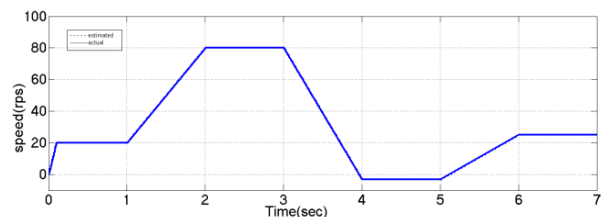
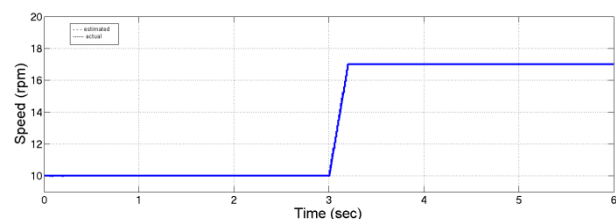

Fig-10: Actual and estimated speeds under the condition of loss of observability

5.3 variation of R_r

The robustness of the proposed observer is tested with sensorless control and a 10 Nm. At time t=3sec the give speed is changed from 9 to 18 rpm; meanwhile R_r is changed from 1.3 to 1.7 Ω during 0.2 sec. The observations $\hat{z}_1(i_{sa})$ and $\hat{z}_2(-p\psi_{ra})$ are insensitive to this perturbation. Furthermore, the STA based observer reaches convergence in a finite time (about 0.1sec), which causes the starting time perturbation of speed estimation in fig.11.



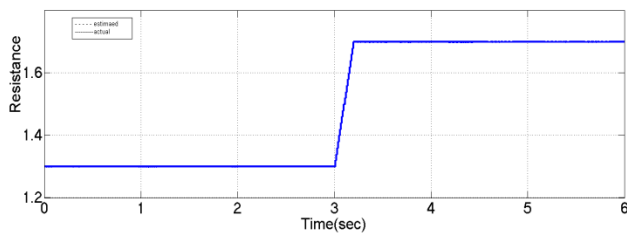

Fig-11: Observation results with R_r variation.

5.4 High speed operation

Fig.12 contrasts the actual and estimated speeds during the acceleration process(150rpm-600rpm-1000rpm) with a 50 Nm load and sensorless control. By utilising the SSM scheme, the system operates stably, and the speed error is acceptable.

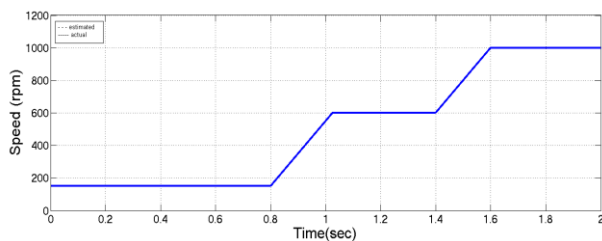

Fig-12: Actual and estimated speeds at acceleration process (150 rpm-600 rpm-1000rpm).

6.CONCLUSION

The disadvantages of induction motor drives with sensors in low speed operation are overcome by using sensorless control. Sensorless control has good dynamic performance, robust to perturbations and also insensitive to parameter variations. This paper presents a modified speed-sensorless control scheme based on second order sliding-mode STA and MRAS estimator. The estimation scheme has been obtained by combining a second order sliding mode current observer with a parallel speed and stator resistance estimator based on rotor flux based MRAS. Both the error in instantaneous phase position and the error in amplitudes are used respectively for speed estimation and R_s estimation, thus overcoming the problems of R_s variation, particularly for low speed operation.

The STA based observer is used as the reference model of the standard MRAS. Derivatives of rotor flux are obtained and designed as the states of MRAS, thus eliminating the integration. Moreover, by making full use of auxiliary surfaces, the observations are insensitive to rotor

parameter perturbation and also the chattering behavior reduced at the same time. However, since the scheme is designed based on the mathematical model of IM, its observability is generally lost at zero magnetic field frequency.

7. REFERENCES

- [1] F.Briz, M.W.Degner, P.Garcia, and R.D.Lorenz, "Comparison of saliency based sensorless control techniques for ac machines," IEEE Trans.ind.Appl.,vol.40,no.4,pp.1107-1115,Jul./Aug.2004.
- [2] Q.Gao, G. Asher, and M. sumner,"Sensorless position and speed control of induction motors using high-frequency injection and without offline precommissioning,"IEEE Trans.Ind.Electron.,vol.54,no.5,pp.2474-2481,oct.2007.
- [3] Z. Gao, L.Tumer, R.S. colby and B.Lepretter, "A frequency demodulation approach to induction motor speed detection," IEEE Trans.Ind. Appl.,vol.47, no.4,pp.1632-1642,July/Aug.2011.
- [4] V.Vasic, S.N. Vukosavic, and E. Levi, "A stator resistance estimation scheme for speed sensorless rotor flux oriented induction motor drives," IEEE Trans.Energy convers.,vol. 18, no.4,pp.476-483, Dec.2003.
- [5] D.P. Marcetic and S.N. Vukosavic, "Speed sensorless ac drives with the rotor time constant parameter update," IEEE Trans.Ind.Electron.,vol. 54, no.5 pp.2618-2625, oct.2007.
- [6] V.R. Jevremovic, V. Vasic, D.P. Marcetic, and B. Jlefenic, "speed sensorless control of induction motor based on reactive power with rotor time constant identification," IET Elect. Power Appl.,vol. 4, no.6, pp.462-473, Jul. 2010.
- [7] L. Kyo-Beum and F. Blaabjerg, "Reduced order extended Luenberger observer based sensorless vector control driven by matrix converter with with nonlinearity compensation," IEEE Trans.Ind.Electron.,vol.53, no.1, pp.66-75, Feb.2005.
- [8] M.S. Zaky, "Stability analysis of speed and stator resistance estimators for sensorless induction motor drives," IEEE Trans. Ind. Electron.,vol. 59, no.2, pp.858-870, Feb.2012.

[9] M. Barut, S. Bogosyan, and M. Gokasan, "Experimental evaluation of braided EKF for sensorless control of induction motors," *IEEE Trans. Ind. Electron.*, vol.55, no.2, pp. 620-632, Feb.2008.

[10] M.S Zaky, M.M. Khater S.S. Shokralla, and H.A. Yasin, "Wide speed range estimation with online parameter identification scheme of sensorless induction motor drives," *IEEE Trans. Ind. Appl.*, vol. 42, no.3, pp. 694-701, May/Jun.2006.

[11] Z. Zhang, H.S Xu L.Y. Xu and L.E .Helian, "sensorless direct field oriented control of three phase induction motors based on "sliding mode" for washing machine drive applications," *IEEE Trans. Ind. Appl.*, vol. 42, no.3, pp. 694-701, May /Jun.2006.

[12] S. Solvar, V. Le, M. Ghanes, J-P. Barbot and G. Santomena, "sensorless second order sliding mode observer for induction motor," in *Proc. IEEE CCA*, Yokohama, Japan, 2010, pp. 1933-1938.

BIOGRAPHIES

	<p>M. Anka Rao is a Assistant Professor in EEE Department at JNTUA Anantapur. His areas of interest are Power Electronics, Electrical Drives.</p>
	<p>Dr.M. Vijaya Kumar is a Professor in EEE Department and also served as a Director of Admissions at JNTUA Anantapur, Andhra Pradesh. His areas of interest are Electrical Machines, Electrical Drives, Microprocessors and power Electronics.</p>
	<p>B. Mukteswari currently pursuing M. Tech in Power and industrial drives at JNTUA Anantapur, Andhra Pradesh. Her areas of interest are Electrical Drives, Power Electronics.</p>