

EMISSION CHARACTERISTICS OF DIESEL ENGINE FUELED WITH ALGAE BIODIESEL-DIESEL BLENDS

Ganesh Nagane¹, Chandrakishor S. Choudhari²

¹Student, Mechanical Engineering Department, AISSMS's COE, Maharashtra, India

²Assistant Professor, Mechanical Engineering Department, AISSMS's COE, Maharashtra, India

Abstract- Increasing consumption of petroleum fuels all over the world and limitations to the extraction of it has led to measurable increase in its prices per liter. Also, a concern towards its environmental effects is limiting its use. This is asking for an alternate fuel source which will provide a comprehensive solution. Biodiesel is one of the alternatives which are being widely studied. Production of biodiesel from oil seeds is limited by crop land displacement. Production of biodiesel from algae is a promising option. As it is cultivated in ponds, there will be no crop land displacement and its yield is more than that of oil seeds. The present work aims to focus on the performance of a diesel engine with algae oil as fuel. In order to use the oil in engine, its blends with the petroleum diesel were prepared. The properties of algae oil and its blends were tested and the results were compared with properties of neat diesel. It is found that, the properties of neat algae oil and its blends are very close to the properties of neat diesel. Also the calorific value of the blends of algae oil is very close to neat diesel. The results of the tests are inspiring for the aim of this project. The prepared blends were used to run a variable compression ratio engine and its performance is studied. The result shows small reduction in torque, brake power and brake thermal efficiency. Also the specific fuel consumption increases with increase in blending ratio. The emissions of CO, CO₂ and HC decreased with slight increase in emission of NO_x. B10 blend shows good overall result. However it can be concluded that, algae biodiesel can be blended with straight diesel up to 20% to use in a diesel engine without any modification.

Key Words: Algae, Biodiesel, Emissions

1. INTRODUCTION

India is one of the fastest growing markets in the world. The economic growth of country is driving energy consumption across all major sectors. It's making India fourth largest primary energy and petroleum consumer [7]. As the country has limited resources, it makes us think of an indigenous source. Biodiesel, from long is being studied as a promising alternative.

India being an agricultural country, assures enough raw material to produce biodiesel from edible and non-edible oil seeds. However, food security may restrict us to use only nonedible sources for production of biodiesel. **Jatropha, rapeseed, soybean, palm, sunflower** oils are mostly used for production of biodiesel. Apart from oil seeds, animal fats can also be used for production of biodiesel.

Though the oil seeds are very regular source for **production of biodiesel, it's associated with the problem** of crop land displacement. The land which will be used for production of these oil seeds is the same which was producing edible sources. Hence the total land availability for production of edible sources might decrease. This, in turn, will reduce the production of edible oil, increasing their prices. Production of biodiesel from microalgae could be a comprehensive solution to this problem. As these could be grown in ponds or bioreactors, crop land displacement can be avoided. Hence it proves to be a very good alternative along with their better yield than oil seeds.

2. OVERVIEW OF ALGAE BIODIESEL

Algae are unicellular or multi cellular organisms that photosynthesize, but lack the features such as leaves, roots, seeds and flowers. They can commonly be found in aquatic—both freshwater and marine—environments. The microalgae can be grown in both open-culture systems such as ponds, lakes and raceways, or in highly controlled closed-culture systems like photo bioreactors, similar to those used in commercial fermentation processes. The photosynthetic growth of micro algal biomass require light, carbon dioxide, water, organic salts and temperature of 20- 30°C. Cultivating algae in open system is most economical, as it requires least expenses. But the biomass produced in such open system is limited and to increase the yield, closed culture system can be used.

The algal oil is found inside plant cells, linked with proteins and a wide range of carbohydrates like starch, cellulose, hemi-cellulose and pectin. The cell content is surrounded by rather thick wall which has to be opened so the protein and oil can be released. Various methods are available for the extraction of algal oil, such as mechanical extraction with hydraulic or screw, enzymatic extraction, chemical extraction through different organic solvents,

Ultrasonic extraction and supercritical extraction using carbon dioxide.

Biodiesel can be produced by transesterification of algal oil. The transesterification is the reversible reaction of fat or oil (which is composed of triglyceride) with an alcohol to form fatty acid alkyl ester and glycerol. The reaction occurs stepwise: triglycerides are first converted to diglycerides, then to monoglycerides and finally to glycerol [18].

Microalgae are capable of synthesizing more oil per acre than the terrestrial plants as they can double their biomass within 24 hrs [19]. Hence using microalgae to produce biodiesel will not compromise production of food, fodder and other products derived from crops.

3. EXPERIMENTAL SETUP

In the present work, the performance of different blends of diesel-biodiesel is studied in diesel engine. For this purpose, different blends of petroleum diesel and biodiesel were prepared and named B00, B10, B20 and B30. Here, B00 is neat diesel and is used to compare the performance of biodiesel. B10, B20 and B30 are the blends of diesel and algae biodiesel where algae biodiesel is mixed with diesel in proportion of 10%, 20% and 30% respectively by volume.

The engine used for the experimentation is Kirloskar single cylinder diesel engine. Being a VCR engine, the compression ratio can be varied between 12 and 18. The hydraulic dynamometer is used to apply the load on engine output shaft. Data acquisition system is used to collect various parameters of engine. A software "Engine soft" is used to analyze the data. "AVL Digas 444" is a five gas analyzer used for analyzing the emissions of engine.

Table 1: Engine Specifications

Engine Make	Kirloskar TV1 VCR Engine
Number of Cylinders	1
Cycle	4 Stroke
Rated Power	3.5 KW @ 1500 rpm
Cylinder Diameter	87.5 mm
Stroke Length	110 mm
Connecting Rod Length	234 mm
Compression Ratio	12 to 18
Cooling Medium	Water Cooling

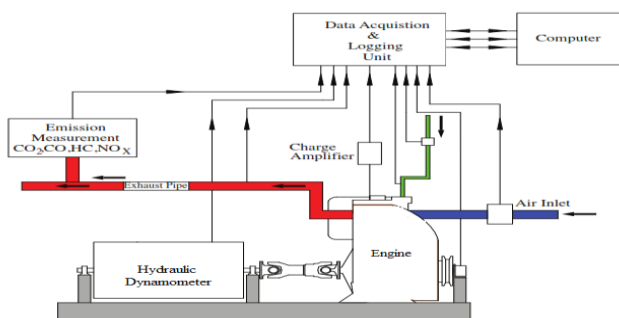

Fig1: Experimental Setup

4. RESULTS AND DISCUSSION

4.1 Effect of Biodiesel Properties

In order to characterize, the properties of blends were studied and compared with diesel. It is found that, the properties of algae biodiesel-diesel blend are very close to the properties of petroleum diesel.

a. Density

Density is measure of mass per unit volume of a material. Biodiesels, in general, are characterized by higher densities than conventional petroleum diesel. This means, volumetrically operating fuel pumps will inject greater mass of fuel. This will affect the air fuel ratio of the engine [14]. In present study, density of biodiesel blends is found to be increasing with the increase in blend ratio.

b. Viscosity

It is measure of internal resistance to flow of a fluid. Higher viscosity of fuel enhances fuel spray penetration and thus improves air fuel mixing [38]. However fuel with higher viscosities cannot be used safely in compression ignition engines [14]. It is seen that the viscosity of blend increases with increase in blending ratio. This limits the blending ratio of diesel and biodiesel.

c. Calorific Value

Calorific value is the measure of heat content of fluid or fuel. It is very well established that, calorific value of biodiesel is lower than petroleum diesel. The same is observed in the study. This also reduces the calorific value of biodiesel blends. This, in turn, means that more fuel will have to be consumed for getting same work output from an engine which is using petroleum diesel. This will increase the specific heat consumption and may lower the torque and power output of the engine.

d. Cetane Number

Cetane number is one of the most important characteristic of fuel. It is a dimensionless number and indicates the ignitability of the fuel [14]. Higher cetane number of fuel promotes faster auto ignition of fuel and reduces the emissions of nitrogen oxides [14]. Cetane number of biodiesel blends in present study is found to be higher than diesel, which creates a possibility of better

combustion and knock free working of engine.

4.2 Exhaust Emissions

Engine trials were conducted at different loads and different compression ratio. At these conditions the exhaust emissions were measured. The result is as tabulated below. In the present work, four major emissions are considered viz. CO, CO₂, HC and NO. Study shows a minor decrement in emissions of CO and HC for lower loads. At higher loads emissions of HC are almost similar to that of diesel. B20 blend shows better results for emissions of CO and HC. Emissions of nitrogen oxides are increases with increase in blend ratio. This may be due to improved automation of biodiesel blends and higher temperatures.

a. Carbon Monoxide and Carbon Dioxide

Carbon monoxide is colorless, odorless poisonous gas. It is generated when engine is operated with fuel rich mixture. It is indicative of incomplete combustion. The study shows a decrement in emissions of carbon monoxide and carbon dioxide for all blends and all loading conditions. The emissions are slightly more for all the blends at lower compression ratio and lower load. Graph below shows the carbon monoxide and dioxides at 100% load and compression ratio of 17.5

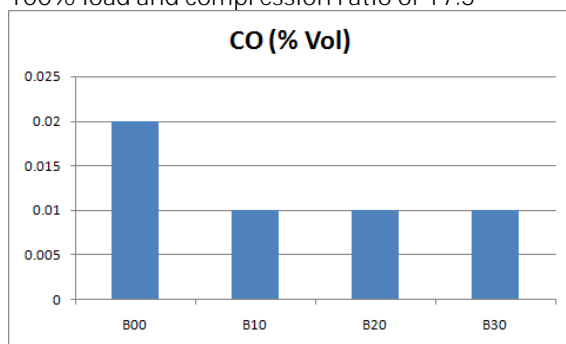

Chart -1: Comparison of CO Emissions (100% Load, C.R. 17)

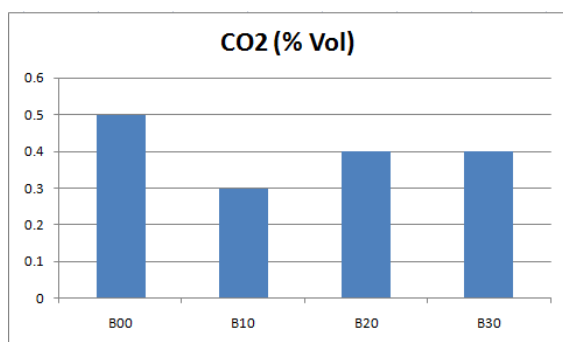

Chart -2: Comparison of CO₂ Emissions (100% Load, C.R. 17)

b. Hydrocarbon (HC)

Hydrocarbon emissions depend on combustion efficiency of the engine. Some fuel particles may condense on the surface of soot. Diesel engines have higher HC emissions. However, it can be observed that, hydrocarbon emissions reduce with increasing load. The study shows minimum hydrocarbon emissions at 100% load and compression ratio of 17.5. Also for all other loading conditions, biodiesel blend show decrement in HC emissions. Graph below shows HC emissions at 100% load and compression ratio of 17.5.

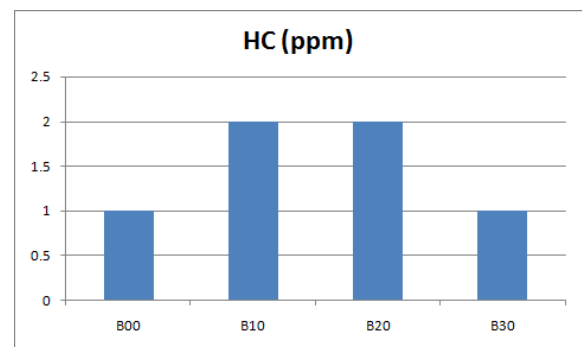

Chart -3: Comparison of HC Emissions (100% Load, C.R. 17)

c. Nitrogen Oxides (NO_x)

It is created mostly from nitrogen in the air. The reaction takes place at higher temperatures. In addition to this, formation of NO_x also depends on availability of excess oxygen. Because of this emission of NO_x increase in biodiesel blends as compared to straight diesel. It is observed that, emissions of NO_x increased for all blends and all loading conditions. Also, it can be observed that, emissions of NO_x increase with increase in blending ratio. Graph below shows the comparison of NO_x emissions at 100% load and compression ratio of 17.

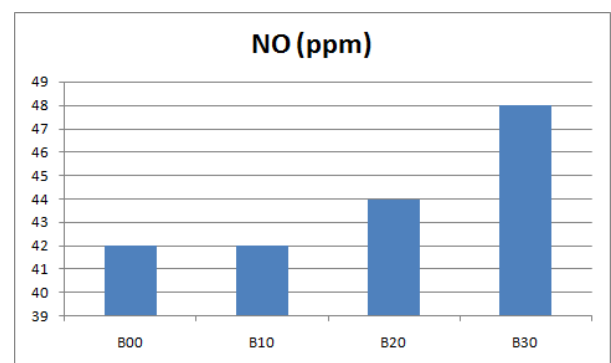

Chart -4: Comparison of NO_x Emissions (100% Load, C.R. 17)

	CO (% Vol.)	CO2 (% Vol.)	HC (ppm Vol)	NO (ppm Vol)
B10, C.R. – 15, 60% Load	0.03	0.60	7	7
B20, C.R. – 15, 60% Load	0.02	0.60	5	21
B30, C.R. – 15, 60% Load	0.02	0.60	7	14
B10, C.R. – 15, 100% Load	00	0.30	5	23
B20, C.R. – 15, 100% Load	00	0.40	1	31
B30, C.R. – 15, 100% Load	0.01	0.40	9	27
B10, C.R. – 17, 60% Load	0.01	0.80	4	41
B20, C.R. – 17, 60% Load	0.02	0.80	2	31
B30, C.R. – 17, 60% Load	0.01	0.40	5	48
B10, C.R. – 17, 100% Load	0.01	0.30	2	18
B20, C.R. – 17, 100% Load	0.01	0.40	2	44
B30, C.R. – 17, 100% Load	0.01	0.40	1	48

Table -2: Comparison of Exhaust Emissions

3. CONCLUSIONS

To use with diesel, the blends of straight diesel and algae biodiesel were prepared. The physiochemical properties of these blends were tested. It is found that:

- Density of blend increases with blending ratio.
- Due to higher viscosity of algae biodiesel, the viscosity of blend also increases with increase in blending ratio.
- Algae biodiesel possesses lower calorific value than straight diesel. Because of which, calorific value of biodiesel blends also decreases with increase in blending ratio.
- However, as cetane number of algae biodiesel is more than straight diesel. The cetane number of biodiesel blends improves with increase in blending ratio.

The blends of biodiesel were tested in VCR diesel engine. The study shows that:

- The emissions of carbon monoxide decrease with the use of biodiesel as compared to straight diesel.

- The emissions of carbon dioxide also decreased with use of biodiesel with the straight diesel.
- The blending of biodiesel with diesel has minimal effect on emissions of hydrocarbon.
- The emissions of nitrogen oxides, however, increased with increase in blending ratio.
- All the blends show better performance at higher load and higher compression ratio.

ACKNOWLEDGEMENT

I am grateful to Mrs. SupriyaBobade and “Indian Biodiesel Corporation”, Baramati for their support. I am also thankful to Head, Mechanical Engineering, Cummins College of Engineering for Women, Pune, for their assistance in this work.

REFERENCES

- Niraj s. Topare, V.C. Renge, Satish V. Khedkar, Y.P. Chavan & S.L. Bhagat, “Biodiesel from algae oil as an alternative fuel for diesel engine,” *ijCEPr*, Vol.2, No. 2-3, 116-120, May-December 2011.
- Snapshot of India’s oil and gas data, Petroleum planning & analysis cell, Ministry of Petroleum & Natural Gas, India, January 2015
- Indian petroleum and natural gas statistics, Ministry of Petroleum & Natural Gas, India, 2013-14
- “Comparative price of crude oil in 2009 and 2014”, Government of India
- Biodiesel in India: Value chain organisation and policy options for rural development / Tilman Altenburg, Bonn: DIE, 2009. – (Studies /DeutschesInstitutfürEntwicklungspolitik ; 43) ISBN 978-3-88985-379-0
- “National policy on biofuels”, Ministry of New & Renewable Energy, Government of India.
- “Biofuels annual”, 2013, GAIN report number IN3073.
- A. K. Bajhaiya, S. K Mandotra, M.R. Suseela*, Kiran Toppo and S. Ranade, “ALGAL BIODIESEL: the next generation biofuel for India”, *AJEBS*, IISN 0975-5845.
- Marc Veillette, Mostafa Chamoumi, JosianeNikiema, Nathalie Faucheux and MichèleHeitz, “Production of Biodiesel from Microalgae”, *Advances in chemical engineering*, ISBN 978-953-51-0392-9.
- Hariram V., G.Mohan Kumar, “Combustion analysis of algal oil methyl ester in a direct injection compression ignition engine”, *Journal of Engineering Science and Technology*, Vol. 8, No. 1 (2013) 77 – 92.

- [11] J.A.Kinsat, "Production of biodiesel from multiple feedstocks and properties of biodiesels and biodiesel-diesel blends", NREL/SR-510-31460.
- [12] Document on "Introduction to biodiesel production", author unknown
- [13] Ulf Schuchardt, Ricardo Sercheli and Rogério Matheus Vargas, "Transesterification of Vegetable Oils: a Review", J. Braz. Chem. Soc., Vol. 9, No. 1, 199-210, 1998.
- [14] Evangelos G. Giakoumis, "A statistical investigation of biodiesel physical and chemical properties, and their correlation with the degree of unsaturation", Renewable Energy, Vol. 50, pp. 858-878, 2013
- [15] Mustafa Balat, Havva Balat, "A critical review of bio-diesel as a vehicular fuel", Energy Conversion and Management 49 (2008) 2727-2741.
- [16] Specification for biodiesel – ASTM D6751 – 12
- [17] Specification for diesel – ASTM D975
- [18] Yusuf Chisti, "review paper on biodiesel from microalgae", Biotechnology Advances 25 (2007) 294-306
- [19] Bryan R. Moser, "Biodiesel production, properties, and feedstocks", In Vitro Cell.Dev.Biol.—Plant (2009) 45:229-266
- [20] John R. Benemann, "Opportunities and challenges in algae biofuels production", algae world 2008
- [21] Teresa M. Mata, Antonio A. Martins, Nidia. S. Caetano, "Microalgae for biodiesel production and other applications: A review", Renewable and Sustainable Energy Reviews 14 (2010) 217-232.
- [22] R.Murali Manohar, M.Prabhakar, Dr.S.Sendilvelan, "Bio-Diesel production and Effect of Catalytic Converter on Emission performance with Bio-Diesel Blends", International Journal of Engineering Science and Technology Vol. 2(6), 2010, 2133-2139
- [23] S. Jaichandar and K. Annamalai, "The Status of Biodiesel as an Alternative Fuel for Diesel Engine – An Overview", Journal of Sustainable Energy & Environment 2 (2011) 71-75
- [24] Jinlin Xue, Tony E. Grift, Alan C. Hansen, "Effect of biodiesel on engine performances and emissions", Renewable and Sustainable Energy Reviews 15 (2011) 1098-1116
- [25] Xiaohu Fan and Rachel Burton, "Recent Development of Biodiesel Feedstocks and the Applications of Glycerol: A Review", The Open Fuels & Energy Science Journal, 2009, 2, 100-109
- [26] Ala'a Alsouady, Mette Hedegard Thomsen & Isam Janajreh, "Influence on process parameters in transesterification of vegetable and waste oil – a review", IJRRAS 10 (1), January 2012
- [27] Jerry Johnson, Nicolas Enjalbert, Joel Schneekloth, Alan Helm, Ravi Malhotra, Daren Coonrod, "Development of Oilseed Crops for Biodiesel Production under Colorado Limited Irrigation Conditions", Colorado water institute, April 2009
- [28] Kazi Mostafijur Rahman, Mohammad Mashud, Md. Roknuzzaman and Asadullah Al Galib, "Biodiesel from jatropha oil as an alternative fuel for diesel engine", International Journal of Mechanical & Mechatronics IJMME-IJENS Vol: 10 No: 03
- [29] Avinash Kumar Agarwal, Atul Dhar, "Experimental investigations of performance, emission and combustion characteristics of Karanja oil blends fuelled DIC engine", Renewable Energy 52 (2013) 283-291
- [30] M.Harinathareddy, P.Nageswara Reddy and K.Vijayakumar Reddy, "Performance and Emission Characteristics of a Diesel Engine Operated on Mahua Oil Methyl Ester", Elixir Mech. Engg. 55 (2013) 12978-12982
- [31] Alp Tekinergenc, Leventyukse, Orkunozen, "Performance, emission, and heat release analyses of a direct injection diesel engine running on diesel and soybean ester blends", Turkish J Eng Env Sci (2013) 37: 23 – 32
- [32] Ahmet Necati Ozsezen, Mustafa Canakci, "Determination of performance and combustion characteristics of a diesel engine fueled with canola and waste palm oil methyl esters", Energy Conversion and Management 52 (2011) 108-116
- [33] Jawad Nagi, Syed Khaleel Ahmed, Farrukh Nagi, "Palm Biodiesel an Alternative Green Renewable Energy for the Energy Demands of the Future", ICCBT 2008
- [34] D. Subramaniam, A. Murugesan, A. Avinash, "A comparative estimation of C.I. engine fuelled with methyl esters of punnai, neem and waste cooking oil", international journal of energy and environment, Volume 4, Issue 5, 2013 pp.859-870
- [35] Engine performance parameters, unknown author
- [36] J. Van Gerpen, B. Shanks, and R. Pruszko, "Biodiesel Analytical Methods", NREL/SR-510-36240
- [37] Pritee Purohit, Sanjay Gaikwad, Raviraj Gurav, "Properties and specifications of biodiesel and their influence on performance of engine: A Review", i-CORT 2012, IOK, Pune

BIOGRAPHIES



The author has completed bachelors in Mechanical Engineering from Solapur university, Solapur. He is currently pursuing M.E. Mechanical in SavitribaiPhule Pune University, Pune, Maharashtra.



The author has completed M.E. Mechanical in Heat Power. He is presently working as assistant professor at AISSMS's **College of Engineering**, Pune, Maharashtra.